



E Layer for Field Hockey/ Lacrosse Field Turf Project

TCNJ Advertised Bid # AB210001

PROJECT REQUIREMENTS

SCOPE OF WORK

DRAWINGS

August 5, 2020

E-Layer Installation

Scope of Work Summary

This project will install a new E-Layer for the Field Hockey Lacrosse turf field. This will include installation of new poured e-layer, finish stone, base stone and panel piping in accordance with the plans and specifications. Contractor shall ensure that the new e-layer and stone base meet the FIH standards.

Contractor will remove and dispose of the existing e-layer, finish stone, base stone, and flat panel piping. The existing 8" perimeter pipe shall remain and will be inspected by the contractor and the Colleges engineer to determine its condition and identify any sections that may need replacement.

Contractor shall also have a third party perform infiltration testing to determine the porosity after the installation of base and finish stone. Contractor will submit an infiltration report to the College and College's Engineer for approval prior to the installation of the e-layer. Contractor will then have the third party perform another day's worth of infiltration testing after the installation of the e-layer to determine the porosity.



Please place the following advertisement in the Legal Section of Classified Advertising. Please ensure that the invoice for this advertisement is prepared and an affidavit forwarded to The College of New Jersey, Office of Finance and Business Services, Administrative Services Building, Room 201, P.O. Box 7718, Ewing, NJ 08628-0718.

To be published on **August 5, 2020**. Contact person regarding placement of ad is Roselle Horodeski (609) 771-2894 or horodesk@tcnj.edu.

**THE COLLEGE OF NEW JERSEY
ADVERTISEMENT FOR BIDS
BID #AB210001**

Under the provisions of the State College Contracts Law, Chapter 64 of Title 18-A, The College of New Jersey will receive sealed bids for the **E Layer for Field Hockey Lacrosse Field Turf Project** until **2:00 P.M. on the 26th day of August, 2020** at The College's Office of Finance and Business Services, Administrative Services Building, Second Floor, Room 201, Route 31 (Pennington Road), Ewing Township, New Jersey. At 2:00 P.M. all bids will be publicly opened and read in Room 203 of the Administrative Services Building.

The project will be bid as a Single Lump Sum.

No bidder may submit more than one bid.

Bid Documents may be obtained on/after **August 5, 2020** via our website (www.tcnj.edu/~budfin/).

A **strongly encouraged on-site inspection** is scheduled on **August 11, 2020 at 11:30 A.M.** at the Field Hockey Lacrosse Field, located on The College's Ewing Township, New Jersey campus on Route 31 (Pennington Road). There will be no other time designated for this site visit.

Bidders are required to comply with the requirements of P.L. 1975 c. 127 (N.J.S.A. 10:5-31 et seq. and N.J.A.C. 17:27 - Affirmative Action); the New Jersey Prevailing Wage Act, N.J.S.A. 34:11-56.25 et seq.; N.J.S.A. 52:25-24.2, "Statement of Ownership Disclosure"; the Public Works Contractor Registration Act (N.J.S.A. 34:11-56.48 et seq.); the New Jersey Business Registration of Public Contractors provisions (N.J.S.A. 52:32-44); Executive Order 117 and P.L. 2005 Chapter 51 (N.J.S.A. 19:44a-1 et seq.) and all amendments thereto

A bid bond is required in the amount of 10% of the total bid. Bid bond shall consist of a certified check or cashiers check to the order of The College of New Jersey, or an individual or annual bid bond issued by an insurance company or surety company authorized to do business in the State of New Jersey. The successful Bidder(s) is required to provide a Performance and Payment Bond equal to 100% of the contract. A Surety Disclosure Statement and Certification form must accompany the performance bond.

The College will award the contract to the lowest responsible bidder who satisfies the qualification criteria as set forth in the contract documents.

The College of New Jersey reserves the right to reject all bids or to waive any minor informalities in the bidding in accordance with law. No bid shall be withdrawn for a period of sixty (60) days subsequent to the opening of bids without the consent of The College of New Jersey.



E Layer for Field Hockey Lacrosse Turf Field Project Milestone Schedule

Date: 8/4/20

| | |
|--|--------------------|
| Advertise for bidding | August 5, 2020 |
| Site Visit, at 11:30 am* | August 11, 2020 |
| Cut off for questions | August 13, 2020 |
| Addendum issued | August 18, 2020 |
| Bids Received | August 26, 2020 |
| Notice of Intent to Award issued | September 1, 2020 |
| End of Protest Period | September 8, 2020 |
| Notice to proceed issued by | September 10, 2020 |
| Submittals submitted and approved by | September 11, 2020 |
| Start Construction in Field | September 11, 2020 |
| Substantial Completion, base and E layer | October 16, 2020 |
| Contract closed out by | November 20, 2020 |

***Due to COVID-19 restrictions, face coverings(masks) and social distancing are required**

**THE COLLEGE OF NEW JERSEY
Construction Bid Proposal Form**

Office of Finance & Business Services
Administrative Services Building, Rm. 201
2000 Pennington Road
Ewing, New Jersey 08628-0718

Bid Number: AB210001
Bid Due Date: August 26, 2020

Project Name: E Layer for Field Hockey Lacrosse Field Turf

BIDDER INFORMATION

Firm Name:

Telephone Number:

Contact Person:

Fax Number:

Address:

Email Address:

Federal I.D. Number:

SOLICITATION OF CONSTRUCTION BIDS

1. Bid proposals are solicited as follows:
 - A. Single Bid (Lump Sum) which combines all trades.
 - (1) The total number and types of trades are set forth in the Specifications.
 - (2) Bidder enters the Bid Price on the line provided.
 - (3) Pursuant to the requirements of N.J.S.A. 18A:64-76.1., bidder lists the names of the subcontractors on the Subcontractor Information page.

2. The scope of work includes, but is not limited to, installation of a new poured e-layer, finish stone, base stone and panel piping in accordance with the plans and specifications. Contractor shall ensure that the new e-layer and stone base meet the FIH Standards. Contractor will remove and dispose of the existing e-layer, finish stone, base stone, and flat panel piping. The existing 8" perimeter pipe shall remain and will be inspected by the contractor and the College's engineer to determine its condition and identify any sections that may need replacement. See complete Scope of Work attached.
 - A. See Specifications and Drawings for Details (included in RFP package).
 - B. The College may issue Addenda or Clarifications which may include additions to or deletions from the scope of work; changes to the Specifications, Drawings, and proposal form; and clarifications of requirements. Bidder is advised to review all Addenda and/or clarifications carefully, and shall note the receipt of same with their bid package.

GENERAL INSTRUCTIONS AND REQUIREMENTS

1. PRICES

- A. Bidder submits prices for the Base Bid and any Alternate Proposals and Unit Prices which are listed for the contract of the bid. If there is no cost associated with the Alternate or Unit Price, bidder is required to enter “0.00” or “no change”.
- B. Prevailing wage rates apply (Mercer County).
- C. Bid is to remain good for sixty (60) days after the Bid Due Date.

2. BOND REQUIREMENTS AND SURETY STANDARDS

- A. Bidder must submit with its bid a Certified Check in the amount of ten percent (10%) of the total bid, or a Bid Bond in the amount of ten percent (10%) of the total bid.
- B. The successful bidder must submit a Performance and Payment Bond equal to 100% of the contract. A completed Surety Disclosure Statement and Certification must accompany the Performance and Payment Bond.
 - (1) The Performance and Payment Bond form and a sample Surety Disclosure Statement and Certification form are included at the end of this Construction Bid Proposal Form.
- C. All bid deposits shall be returned within three (3) days, Sunday and holidays excepted, after the awarding of the contract and the approval of the successful bidder’s performance bond, if any, the bid guaranty of the remaining bidders shall be returned to them.
- D. Should the successful bidder fail to enter into said contract after acceptance of bid by the College, then the check or security deposited by that bidder shall, at the option of the College, be retained as liquidated damages, or if Bid Bond has been supplied, principal and surety shall be liable to the amount of the Bid Bond.
- E. Attorneys-in-fact who sign bid bonds or contract bonds must file with each bond a certified copy of their Power of Attorney to sign said bonds.

3. LICENSES, CERTIFICATIONS, REGISTRATIONS, QUALIFICATIONS

- A. The bidder or, as applicable, its subcontractors shall at the time of bid have those required licenses, certifications, registrations, qualifications and the like (“LCRQ”) listed below and shall present satisfactory evidence thereof upon request of the College prior to the notice of intent to award.
- B. The selected bidder/contractor or, as applicable, its subcontractors shall have and shall present satisfactory evidence of all other required LCRQ noted in the Specifications after execution of contract during the submittal process and prior to the start of the applicable work, unless otherwise requested by the College or a date or event specified for that LCRQ in the Specifications.

4. SUBCONTRACTORS

- A. Pursuant to New Jersey State Law (N.J.S.A. 18A-76.1), a Single Bid (Lump Sum) bidder discloses its subcontractors to whom the bidder intends to subcontract the work. The Subcontractor Information sheet is provided for this purpose.
5. Under Executive Order 34, the College is responsible for soliciting demographic information from its vendors. The College is required to seek the following information from each firm under contract with the College:
1. Is more than fifty percent (50%) of your company minority owned? (circle one) YES NO
(African-American, Hispanic, Asian, and/or Native American)
 2. Is more than fifty percent (50%) of your company woman owned? (circle one) YES NO
 3. What is the ethnicity of the owner of your company: (check applicable according to 51% ownership)
 - Asian American
 - Multiple Ethnicities
 - Non-Minority
 - Hispanic American
 - African American
 - Caucasian American Female
 - Native American
 - Unspecified

The College is required to solicit the foregoing information. Your response, however, is **strictly voluntary**. Please be advised that any contracting decisions made by the College will **not** be influenced in any way by your decision to provide the above information.

EXECUTIVE ORDER #34: MINORITY AND WOMEN BUSINESS ENTERPRISES

On September 15, 2006, Governor Corzine signed Executive Order 34 establishing a Division of Minority and Women Business Development. The Division is charged with administering and monitoring policies, practices, and programs to ensure that minority and women business enterprises (MWBE) are afforded an equal opportunity to participate in New Jersey’s purchasing and procurement processes.

State entities are required to report to the Division the ethnic and gender composition of the vendors with which those state entities do business.

6. Bidder completes Statement of Ownership Disclosure form and the Non-Collusion Affidavit form.
7. ~~Bidders are required to be registered with the New Jersey Department of Property Management and Construction (DPMC) and possess a DPMC C008 classification at the time of bid submission.~~

8. SET ASIDE PROGRAM FOR SMALL BUSINESS ENTERPRISE (SBE) – CONSTRUCTION

In accordance to N.J.A.C., 17:14-1.2 et seq. and Executive Order 71, signed by Governor James E. McGreevey in 2003, the College requires bidders to make a good faith effort to provide opportunities for Small Business Enterprises (SBE) to participate in the performance of this contract as subcontractors consistent with the overall goals established for construction services by the New Jersey Commerce and Economic Growth Commission (NJ Commerce).

SBE subcontracting goals are not applicable if the bidder is currently registered with NJ Commerce as an SBE firm.

9. PREVAILING WAGE AND PUBLIC WORKS CONTRACTOR REGISTRATION ACTS

- The work described in this project is subject to the New Jersey Prevailing Wage Act, N.J.S.A. 34:11-56.25 et seq. and the Public Works Contractor Registration Act, N.J.S.A. 34:11-56.48 et seq.
- The Public Works Contractor Registration Act requires the bidder and any subcontractors listed in the bid to be registered with the New Jersey Department of Labor and Workforce Development at the time the bid is submitted. The contractor must submit registration certificates for all listed subcontractors prior to award of the contract.
- The Contractor must comply with the New Jersey Prevailing Wage Act, N.J.S.A. 34:11-56.25 through 56.47. Workers employed by the Contractor or any subcontractor or sub-subcontractor in the performance of services directly on the project must be paid prevailing wages. As required by N.J.S.A. 34:11-56.27 and 56.28, this contract cannot become effective until the College obtains from the New Jersey Department of Labor and Workforce Development a determination of the prevailing wage rates applicable to the project as of the contract award date and attaches a copy to the contract. As required by N.J.S.A. 34:11-56.27, the Contractor or any subcontractor may be terminated if any covered worker is not paid prevailing wages on the project, and the Contractor and its surety shall be liable for any additional costs which result. The Contractor and its subcontractors must be registered with the New Jersey Department of Labor and Workforce Development (N.J.S.A. 34:11-56.51 et seq.), and the prevailing wage rates must be posted at the job site (N.J.S.A. 34:11-56.32). The Contractor and its subcontractors must prepare accurate certified records of wages paid for each worker on the project (N.J.S.A. 34:11-56.29), and copies for the period covered by each invoice must be attached to the invoice submitted under the contract. In accordance with N.J.S.A. 34:11-56.33, the Contractor's final invoice must include a statement of all amounts still then due to workers on the project. The Contractor is also cautioned that it must use job titles and worker classifications consistent with those approved by the Department of Labor and Workforce development, and that, if it intends to pay apprentice rates, it must comply with the Department of Labor and Workforce Development regulations at N.J.A.C. 12:60.

- Please refer to http://lwd.dol.state.nj.us/labor/wagehour/wagerate/wage_rates.html for official wage rate determinations for Mercer County, NJ.

10. NEW JERSEY EQUAL PAY ACT

On April 24, 2018, Governor Phil Murphy signed into law New Jersey's Diane B. Allen Equal Pay Act (P.L. 2018, c. 9) The law provides in pertinent part that as of July 1, 2018, any employer entering into a contract with the State of New Jersey or an instrumentality of the State for "qualifying services" or "public works" must provide to the Department of Labor and Workforce Development – upon commencement of the contract – wage and demographic data for all employees who are employed in connection with the contract (for public works) and for all employees (for qualifying services). This requirement DOES NOT apply to employers who are contracting with local governments (for example: municipalities and counties). The report must contain the gender, race, ethnicity, job category, compensation, and number of hours worked by each employee.

The extent of the Department of Labor and Workforce Development's responsibilities under the Equal Pay Act is the collection of data regarding compensation, hours worked, job/occupational category, job title, gender, race, and ethnicity for State contactors and making that data available to the Division on Civil Rights (DCR), within the Department of Law and Public Safety, and upon request to certain individuals. Complaints of unlawful discrimination under the Equal Pay Act should be directed to the DCR, as should any questions regarding the filing of such a complaint.

The Department of Labor and Workforce Development has issued two forms, as required by the law, to be completed by employers. The forms should be used to report the employee's wage and demographic data and can be found on the LWD website (<http://www.nj.gov/labor/equalpayact>). **A completed copy of the forms is not required at time of bid; however, it will be required of the bidder who receives the notice to proceed from the College. Completed forms should be emailed to: equalpayact@dol.nj.gov**

11. In order for your proposal to be accepted and deemed valid, your company/firm will be required to comply with the requirements of N.J.S.A. 19:44A-1 et seq/P.L. 2005 Ch. 51 ("Chapter 51") and Executive Order 117. Enclosed are the requirements of Chapter 51 and Executive Order 117, the forms for Certification and Disclosure. The contract that will be generated based on this bid proposal cannot be awarded without approval of the Certification and Disclosure forms by the State of New Jersey, Department of Treasury. **A completed copy of your Certification form is not required at time of bid; however, it will be required from the bidder who receives the notice of intent to award from the College prior to the execution of the contract.**
12. Pursuant to N.J.S.A. 52:32-44, The College of New Jersey ("Contracting Agency") is prohibited from entering into a contract with an entity unless the bidder/proposer/contractor, and each subcontractor that is required by law to be named in

a bid/proposal/contract has a valid Business Registration Certificate on file with the Division of Revenue and Enterprise Services within the Department of the Treasury.

Prior to contract award or authorization, the contractor shall provide the Contracting Agency with its proof of business registration and that of any named subcontractor(s).

Subcontractors named in a bid or other proposal shall provide proof of business registration to the bidder, who in turn, shall provide it to the Contracting Agency prior to the time a contract, purchase order, or other contracting document is awarded or authorized.

During the course of contract performance:

- (1) the contractor shall not enter into a contract with a subcontractor unless the subcontractor first provides the contractor with a valid proof of business registration.
- (2) the contractor shall maintain and submit to the Contracting Agency a list of subcontractors and their addresses that may be updated from time to time.
- (3) the contractor and any subcontractor providing goods or performing services under the contract, and each of their affiliates, shall collect and remit to the Director of the Division of Taxation in the Department of the Treasury, the use tax due pursuant to the Sales and Use Tax Act, (N.J.S.A. 54:32B-1 et seq.) on all sales of tangible personal property delivered into the State. Any questions in this regard can be directed to the Division of Taxation at (609)292-6400. Form NJ-REG can be filed online at <http://www.state.nj.us/treasury/revenue/busregcert.shtml>.

Before final payment is made under the contract, the contractor shall submit to the Contracting Agency a complete and accurate list of all subcontractors used and their addresses.

Pursuant to N.J.S.A. 54:49-4.1, a business organization that fails to provide a copy of a business registration as required, or that provides false business registration information, shall be liable for a penalty of \$25 for each day of violation, not to exceed \$50,000, for each proof of business registration not properly provided under a contract with a contracting agency.

- 13. Record Retention:** Pursuant to N.J.A.C. 17:44-2.2, the vendor shall maintain all documentation related to products, transactions or services under this contract for a period of five years from the date of final payment. Such records shall be made available to the New Jersey Office of the State Comptroller upon request.
- 14. Energy Star energy efficient products:** Under Executive Order #11 (Corzine), the College is required to select ENERGY STAR energy-efficient products when acquiring new energy-using products or replacing existing equipment. For products

that do not have ENERGY STAR labels, vendors shall follow guidelines established by the New Jersey Clean Energy Program.

15. QUESTIONS

- A. Direct inquiries and correspondence relating to this proposal form and questions regarding the technical specifications and requests for clarification must be submitted in writing via **email to horodesk@tcnj.edu** and must be received **prior to 4:00 p.m., on August 13, 2020.**
- B. Should any questions be received, a notice will be placed in the newspaper and the addendum or clarification will be available on **August 18, 2020 on the College's website at <https://bids.tcnj.edu/>.** **If an addendum and/or clarification is posted, it SHOULD be noted in the General Agreement section of the bidder's proposal. Failure to do so may subject Bidder to disqualification.**

16. HOW TO SUBMIT THE COMPLETED CONSTRUCTION BID PROPOSAL FORM

- A. Bidder places all pages of the completed form and the requisite additional documents in an envelope, seals the envelope, and labels it with his/her firm name, address, and "Sealed Bid Enclosed for (**Bid Number and Project Name**)".
 - B. Bidder mails or deliver by hand the sealed bid, no later than **2:00 p.m., August 26, 2020**, to The College of New Jersey, Attention: Roselle Horodeski for (specify the Bid Number), Office of Finance & Business Services, Room 201, 2000 Pennington Road, Ewing, New Jersey 08628-0718. **At 2:00 p.m., all bids will be publicly opened and read in Room 203 of the Administrative Services Building.**
 - C. Contractors are advised that the U.S. Postal Service and all express mail companies deliver to The College's Mail Room or Receiving Department, not directly to the Office of Budget & Finance. The College is not responsible for lost or misdirected bids.
17. Any bid not prepared and submitted in accordance with the provisions described herein may be rejected by the College. Any bid received after the time and date specified will not be considered. No bidder shall withdraw a bid within sixty (60) days after the date of the bid opening. Contracts shall be awarded to the lowest responsible bidder whose bid, conforming to the invitation for bids, will be the most advantageous to the State college
18. Any bidder who has defaulted on any contract with the College or any other State Agency may be considered as not responsible and their bid may be rejected. THE COLLEGE OF NEW JERSEY reserves the right to exercise this option, as the College deems proper and/or necessary in accordance with applicable law.

19. Bids shall include all costs of any nature necessary to complete the project in the manner and within the time required by the contract.
20. The College reserves the right to require bidders to provide a schedule of values of their lump sum bid price upon request.
21. The College is exempt from all taxes including Federal Excise Tax, Transportation Taxes, State Excise, Sales Tax and local taxes. Rentals of equipment for 28 days or less is not exempt from any tax under the State sales tax act.
22. Before submitting his bid, the bidder shall be familiar with the Drawings, Specifications, and other Documents that will form part of the contract and shall have visited the site of the project to confirm for themselves the character and amount of work involved.
23. No bidder shall be allowed to offer more than one price on each item even though he/she may feel that he/she has two or more types or styles that will meet specifications. Bidders must determine for themselves which to offer. This may be cause for automatic rejection of bid.
24. It is understood and agreed that all prices quoted are firm and not subject to any increase during the life of the contract.
25. Should any difference arise between the contracting parties as to the meaning or intent of these instructions or specifications, the College's decision shall be final and conclusive.
26. Should the bidder discover discrepancies in this Request for Bids, the matter shall be at once brought to the attention of the College, and the discrepancies corrected by written agreement before submission of bid. The correction will be issued by addendum.

27. ACCEPTANCE/REJECTION OF BIDS

- A. THE COLLEGE OF NEW JERSEY, pursuant to State College Contract Law, Contracts shall be awarded to the lowest responsible bidder whose bid, conforming to the invitation for bids, will be the most advantageous to the State college.
- B. The bid is irrevocable by the bidder or the bidder's representatives. The bid, and any award made to the bidder by the College, shall bind the bidder and the bidder's heirs, executors, administrators, successors or assigns.
- C. Award of contract shall be made to the lowest responsible bidder, whose bid, conforming to the invitation for bids, is the most advantageous to the College.
- D. The award of the contract or the rejection of the bids shall be made within sixty (60) days of the date of receiving bids, unless written extensions are requested by the College and accepted by the bidder(s). All bid securities shall be returned immediately if all bids are rejected. The successful bidder(s) to whom the award

is to be made will be notified by receipt of a written "Intent to Award" from the College.

- E. When award of contract is made in one fiscal year with effective date in the next fiscal year, award shall be contingent upon the availability and appropriation of sufficient funds for that purpose for the year in which said contract takes effect. When a contract shall be awarded for a period in excess of one year, said contract shall be contingent upon the annual availability and appropriation of sufficient funds for that purpose for each year of the contract term.

28. WITHDRAWAL OF BIDS

- A. A written request for the withdrawal of a bid, or any part thereof, will be granted if the request is received by the College prior to the specified time of the bid opening.
- B. Should the bidder refuse to perform the work for the price provided, they will forfeit their bid security and will be held liable for the difference between their low bid and the next highest/responsive bidder.

29. OSHA COMPLIANCE:

- A. The Contractor shall guarantee that all materials, supplies and equipment to be provided under his contract shall meet all applicable requirements, Specifications and standards of the Federal Occupational Safety and Health Act (OSHA) of 1970 as amended to date of acceptance by the College, and shall also apply to Contractors Construction procedures.

30. APPLICABLE LAWS:

- A. The following list of statutes and regulations, which may be applicable in whole or in part, is provided for the benefit of the Contractor and is not meant to be all-inclusive. In the event that other laws are applicable, it shall be the responsibility and obligation of the Contractor to ascertain and comply with them.

- (1) New Jersey Statutes and Regulations

- N.J.S.A. 10:5-31 *et seq.* and N.J.A.C. 17:27-1 *et seq.*, Affirmative Action

- Prevailing Wage Act, N.J.S.A. 34:11-56.25 *et seq.*

- N.J.S.A. 52:32-44, Business Registration Certificate

- N.J.S.A. 34:11-56.48 *et seq.*, Public Works Contractor Registration Act

- (2) Federal Statutes

- Immigration Control and Reform Act (1986) – 8 U.S.C.A. Section 1324(a) *et seq.*

- Civil Rights Act of 1964 – 42 U.S.C.A. Section 1971 *et seq.*

- The Americans with Disabilities Act of 1990

31. EXAMINATION OF SITE, DRAWINGS AND SPECIFICATIONS

- A. Each Bidder shall visit the site of the proposed work and fully acquaint themselves with the conditions as they exist so that they may fully understand the

facilities, difficulties, and restrictions attending the execution of the work under this Contract.

- B. Bidders shall also thoroughly examine and be familiar with the Drawings and Specifications. The failure to receive or examine any form, instrument or document, or to visit the site and acquaint himself with conditions there existing shall in no way relieve any bidder from obligation with respect to his bid. By submitting a bid, the bidder agrees and warrants that he has examined the site, the Drawings and Specifications and, that the Specifications and Drawings are adequate and the required result can be produced under the Drawings and Specifications. No claim for any extra will be allowed because of alleged impossibilities in the productions of the results specified or because of unintentional errors or conflicts in the Drawings and Specifications. No change orders will be issued for items, materials or issues that existed on or with respect to the site prior to bidding.

32. DRAWINGS AND SPECIFICATIONS

- A. The project shall be performed in accordance with the requirements of the Drawings and Specifications, subject to modification as provided in General Conditions. The Drawings and Specifications are intended to complement and supplement each other.
- B. Any work required by either of them and not by the other shall be performed as if denoted in both. Should any work be required which is not also denoted in the Specifications or on the Drawings because of an obvious omission, but which is, nevertheless, necessary for the proper performance of the project, such work shall be performed as fully as if it were described and delineated.

33. FORM OF AGREEMENT

- A. Every successful bidder shall be required to sign the standard form contract, a copy of which is attached. Any proposed language or form changes which in any way modifies the contractor's responsibilities as set forth in the Contract Documents will not be acceptable and will be deemed to constitute a bid exception.

34. MULTIPLE BIDS NOT ALLOWED:

- A. No bidder is allowed to submit more than one bid from an individual, firm, partnership, corporation or association under the same or different name. This will be cause for automatic rejection of each bid.

35. SUBSTITUTIONS:

- A. The bidder may include in their bid substitute materials or equipment or methods in lieu of those specified in the contract documents, but they do so at their own risk. Any substitution must be equivalent in type, function and quality to the item required in the contract. The successful bidder must submit all information required within 20 days of contract award to

determine if the proposed substitute is equal to the contract requirements, and any substitution must be approved by the architect and the College.

- B.** The College shall have complete discretion to decide whether it will accept any substitution. No substitution shall result in any increase in the contract price or times. The successful bidder in its application for the substitution must certify in writing that the substitution is equal to what is specified in the contract documents in all material respects and will not increase the time or price of the contract work.
- C.** Should the substitution be rejected, the contractor will then be required to provide the specified product, material or method at no additional cost to the College and no change in the project schedule.

36. DOCUMENTS/SUBMISSIONS THAT MUST BE PROVIDED BEFORE CONTRACT AWARD:

- **AFFIRMATIVE ACTION:** The bidder is required to complete and submit a copy of Initial Project Workforce Report (AA-201) to the College and the Division of Public Contracts Equal Employment Opportunity Compliance verifying that the bidder is operating under a federally approved or sanctioned Affirmative Action program. The bidder also agrees to submit a copy of the Monthly Project Workforce Report once a month thereafter for the duration of this contract to The College and the Division.
- **CERTIFICATE OF INSURANCE:** The bidder is required to submit proof of liability insurance in accordance with The College's contract.
- **PUBLIC WORKS CONTRACTOR REGISTRATION CERTIFICATES**
- **P.L. 2005, Chapter 51 / Executive Order 117 - Contractor Certification and Disclosure of Political Contributions:**

In order for your proposal to be accepted and deemed valid, your company/firm will be required to comply with the requirements of Chapter 51 and Executive Order 117. Enclosed are the requirements of Ch. 51 and EO 117, the forms for Certification and Disclosure. The contract that will be generated based on this bid cannot be awarded without approval of the Certification and Disclosure forms by the State of New Jersey, Department of Treasury.

- **New Jersey Business Registration Certificate**
- **All applicable licenses, certificates, and requirements specified in the scope of work, contract documents and specifications.**

The following Bidder's Checklist is provided as an aid to the bidder. It does not in any way relieve the bidder of its responsibility to ensure that its bid proposal is complete.

- a. _____ Bidder has completed the Bidder Information section and General Agreement section and filled out the receipt of addendum and clarifications.
- b. _____ Bidder has completed the form of proposal and indicated base bid for either Separate Bid or Single Bid (Lump Sum all trades), prices for Alternate Proposals, and Unit Prices.
- c. _____ Bidder for Single Bid (Lump Sum) has listed and has disclosed the subcontractors on the Subcontractor Information form.
- d. _____ Bidder has enclosed a certified check or bid bond for ten percent (10%) of the amount of the bid.
- e. _____ Bidder has completed and enclosed the Non-Collusion Affidavit.
- f. _____ Bidder and each disclosed subcontractor has enclosed a copy of its **registration certificate** in accordance with the requirement of the Public Works Contractor Registration Act. (NJ Dept. of Labor and Workforce Development). **A completed copy of your Certification form is not required at time of bid; however, will be required from the bidder who receives the intent to award from the College.**
- g. _____ Bidder has acknowledged the **Affirmative Action Language** in accordance with the requirements P.L. 1975 C.127. (NJAC 17:27-1.1 et seq).
- h. _____ Bidder has enclosed its MWBE information.
- i. _____ Bidder has enclosed its Electrical and Plumbing License and any other licenses, certifications, certifications, and qualifications.
- j. _____ Bidder has enclosed its Vendor Qualification Statement
- ~~k. _____ Bidder has included a copy of its latest Experience Modification Rating (EMR Safety Rating). The College requires an average rating over the last 5 years of 1.25 or less.~~
- ~~l. _____ Bidder has included a copy of its DPMC Notice of Classification and Total Amount of Uncompleted Contracts.~~
- m. _____ Bidder has enclosed a copy of its Chapter 51 & EO117 Certification form. **A completed copy of your Certification form is not required at time of bid; however, will be required from the bidder who receives the intent to award from the College.**
- n. _____ Bidder has enclosed a copy of its New Jersey Business Registration Certificate in accordance with the requirements of the New Jersey Division of Revenue. **A completed copy of your Certificate is not required at time of bid; however, will be required from the bidder who receives the intent to award from the College.**

- o. _____ Statement of Ownership Disclosure(N.J.S.A. 52:25-24.2).**
- p. _____ Disclosure of Investment Activities in Iran (N.J.S.A. 52:32-58).**

GENERAL AGREEMENT

1. Having examined the plans and specifications with related documents and the site of the proposed work and being familiar with all of the conditions surrounding the construction of the proposed project including the availability of materials and labor, the undersigned hereby proposes to furnish all labor, materials, and supplies, and to construct the project in accordance with the Contract Documents, within the time set forth therein, and at the price stated. This price covers all expenses incurred in performing the work required under the Contract Documents, of which this proposal is a part.

2. Bidder acknowledges receipt of the following Addendums/Clarifications:

Addendum Number _____ Date _____ Addendum Number _____ Date _____
Addendum Number _____ Date _____ Addendum Number _____ Date _____
Addendum Number _____ Date _____ Addendum Number _____ Date _____

3. Bidder acknowledges and affirms that he/she has personal knowledge of or has obtained and reviewed a copy of the valid prevailing wage rates at the time of the bid and for the duration of the contract for all trades involved in the project for the geographical location of the project as issued by the Commissioner of the Department of Labor & Workforce Development, Trenton, NJ 08625 (609) 292-2259 or visiting the Department of Labor website at (http://lwd.dol.state.nj.us/labor/wagehour/wagerate/wage_rates.html).

4. Bidder agrees that its price is good and the bid shall not be withdrawn for a period of 60 calendar days after the scheduled Bid Due Date and Time.

5. Upon conclusion of the 5-business day protest period, Bidder will execute the formal contract within 5 business days and deliver as required in the General Conditions: a Performance and Payment Bond; Surety Disclosure and Certification Statement; and certificates of insurance for general liability, automobile and worker’s compensation.

6. Bidder acknowledges work to commence on site not later than ten (10) calendar days after receipt of a Notice to Proceed.

(Seal if bid is by Corporation)

Respectfully submitted,

(Signature of Principal)

(Printed Name of Principal)

(Title of Principal)

PRICES FOR SINGLE BID (LUMP SUM): Base Bid, Alternate Proposals, and Unit Prices
FORM OF PROPOSAL

To: **The College of New Jersey**

for: E-Layer Installation

Date _____

A. BID:

1. **Base:** We, _____, the Undersigned, in accordance with the published advertisement inviting proposals, will furnish all labor, material, equipment and services necessary for the complete construction, as defined in the advertisement, specimen contract, specifications, addendums/clarifications/bulletins, drawings, and proposal, for the Contract amount indicated below for the **above noted project** in strict accordance with the Contract Documents and Addenda thereto for the total sum of:

_____ Dollars \$ _____
 (words)

General Construction (Single overall Prime Contract)

2. ~~Add/Deduct Alternate~~
 Check One: _____ Add _____ Deduct

No Alternates are requested for this bid.

3. CHECK LIST FOR BIDDERS:
 A check list has been provided in these specifications for the use in completing this proposal. Bidders are encouraged to reference said list to minimize the opportunity for errors by the bidder.

B. UNIT PRICES: We, the Undersigned, agree, if awarded the Contract to perform additional work or delete work at the Unit Prices set forth below or at a negotiated unit price (Unit Prices are for work that is in addition to or is deleted from the base bid work):

No Unit Prices are requested for this bid.

C. AGREEMENT: We, the Undersigned, agree, if awarded the Contract, to execute an agreement for the above stated work and compensation on the Standard Form of Agreement Between Owner and Contractor.

D. SURETY: We, the Undersigned, agree, if awarded the Contract, to execute and deliver to the Owner, prior to the signing of the Contract, the Performance and Payment Bonds as required.

- Contractor shall provide a Maintenance Bond at job completion for a period of one year for 100% of the final contract price.

E. BID SECURITY: The attached bid security is to become the Property of the Owner in the event that the Contract and bond are not executed within the time set forth, as liquidated damages for the delay and

additional expense (including the difference between the price provided with said bond and the next lowest responsive bidder) to the Owner caused thereby.

Certified Check \$ _____
Bid Bond \$ _____

F. STATEMENT:

1. We, the Undersigned, acting through its authorized officers and intending to be legally bound, agree that this bid proposal shall constitute an offer by the Undersigned to enter into a Contract with the acts and things therein provided, which offer shall be irrevocable for sixty (60) calendar days from the date of opening hereof and that the Owner may accept this offer at any time during said period by notifying the Undersigned of the acceptance of said offer.

2. We, the Undersigned, acknowledge receipt of the following Addenda/Clarifications:

| Addenda Number | Dated |
|----------------|-------|
| _____ | _____ |
| _____ | _____ |
| _____ | _____ |

The undersigned further agrees to comply with the requirements as to conditions of employment, wage rates, and hours of labor set forth in the Contract Documents.

Dated _____

Firm Name _____ Phone Number: _____

Address _____

**If a corporation, give the State of Incorporation, using the phrase:

"A corporation organized under the laws of _____."

If a partnership, give names of the partners, using also the phrase:

"Co-partners trading and doing business under the firm name and style of _____."

If an individual using a trade name, give individual name, also using the phrase:

"An individual doing business under the firm name and style of _____."

Dated: _____

STATE OF _____

SS.

COUNTY OF _____

_____ being duly sworn say that the several matters stated in this proposal are in all respects true, and that no member of the State or employee of the College are interested in any way in this proposal.

Sworn and subscribed before me _____

Bidder signs above line

this _____ day of _____ 20____

_____ and _____
Print Name Title

SUBCONTRACTOR INFORMATION FOR SINGLE BID (LUMP SUM)

Pursuant to the State Colleges Contract Law, N.J.S.A. 18A:64-76.1, all bids submitted shall set forth the names and license numbers of all subcontractors to whom the bidder intends to subcontract the plumbing and gas fitting work; the refrigeration, the heating and ventilating systems and equipment; the electrical work, including any electrical power plants; tele-data, fire alarm, or security systems; the structural steel and ornamental iron work (individually, the "Trade" or collectively, the "Trades").

For each Trade listed below for which the work will be completed by a subcontractor you must list for each such subcontractor at a minimum the name and, where applicable, license number (or in lieu thereof enclose a copy of the license with this form) and preferably you will also list the subcontractor's address, telephone number, and fax number. If the work will be self-performed by the bidder, you may indicate that by inserting the name of the bidder (next to "Name"). If work by that Trade is not required per the scope of work of the project, you may indicate that by inserting "Not required" (next to "Name"). If the name of a subcontractor is not provided on this form for any one or more of the Trades, the bidder, in submitting its bid, certifies that, for such Trades, either the work will be self-performed by the bidder, or the work is not required per the scope of work.

Failure to complete this form as required may result in your bid being disqualified.

Plumbing and Gas Fitting Work

List information for Subcontractor, if any:

Name: _____
License Number: _____
Address: _____

Telephone: _____
Fax: _____

Refrigeration, Heating and Ventilating Systems and Equipment

List information for Subcontractor, if any:

Name: _____
License Number: _____
Address: _____

Telephone: _____
Fax: _____

Electrical Work, including any Electrical Power Plants, Tele-data, Fire Alarm, or

Security Systems

List information for Subcontractor, if any:

Name: _____

License Number: _____

Address: _____

Telephone: _____

Fax: _____

Structural Steel Work and Ornamental Iron Work

List information for Subcontractor, if any:

Name: _____

License Number: _____

Address: _____

Telephone: _____

Fax: _____

Bidder Name

By: _____
Signature

Printed Name of Signing Individual

Date

SMALL BUSINESS, MINORITY AND/OR FEMALE-OWNED BUSINESS REPORTING

1. Contractor and sub-contractors are requested to check all of the following that apply to their company and, if applicable, submit a copy of their certificate(s):
 - A. My company is certified by the NJ Department of Treasury, Division of Revenue as a:
_____ small business _____ minority-owned business _____ female-owned business
 - B. My company is certified by the NJ Department of Transportation as a:
_____ small business _____ minority-owned business _____ female-owned business
 - C. My company is a _____ small business _____ minority-owned or _____ female-owned but is not certified by either NJ Department.
 - C. _____ My company is not a small business, minority-owned or female-owned.

Signed

Date



PERFORMANCE BOND & PAYMENT BOND

BOND NO. _____

KNOW ALL MEN BY THESE PRESENTS, that we, the undersigned _____ as Principal, and _____, a corporation of the State of _____, duly authorized to do business in the State of New Jersey, having an office at _____, are hereby held and firmly bound unto The College of New Jersey in the Penal Sum of _____ DOLLARS, for payment of which well and truly to be made, we hereby jointly and severally bind ourselves, our heirs, executors, administrators, successors and assigns.

SIGNED this _____ day of _____, 20_____

THE CONDITION OF THE ABOVE OBLIGATION IS SUCH THAT, WHEREAS, the above named Principal did on the _____ day of _____, 20_____, enter into a written contract with The College of New Jersey for _____ which said contract is made a part of this bond as set forth herein;

NOW, if the said _____ shall well and faithfully do and perform the things agreed by _____ to be done and performed according to the terms of the said contract; shall pay all lawful claims of sub-contractors, materialmen, laborers, persons, forms of other suppliers or teams. fuel, oils, implements or machinery furnished, used or consumed in the carrying forward, performing, or completing of said contract, we agreeing and assenting that this undertaking shall be for the benefit of any subcontractor, materialman, laborer, person, firm or corporation having a just claim, as well as for the obligee herein; then this obligation shall be void, otherwise the same shall remain in full force and effect; it being expressly understood and agreed that the liability of the surety for any and all claims hereunder shall in no event exceed the penal amount of this obligation as herein stated.

The said surety hereby stipulated and agrees that no modifications, omissions, or additions in or to the terms of the said contract, or in or to the plans and specifications therefore shall in any wise effect the obligation of said surety on its bond.

This bond is given in compliance with the requirements of the statutes of the State of New Jersey including N.J.S.A. 18A:64-68 and any amendments thereof.

SIGNED, SEALED AND DELIVERED
IN THE PRESENCE OF

Witness

BY: _____

Witness as to Surety

BY: _____
ATTORNEY-IN-FACT

Countersigned

NOTE: General Power of Attorney and the current

this _____ day of _____, 20_____

financial statement of the bonding company
must be attached to each copy (a total of three)
of the Performance Bond.

BY: _____

SURETY DISCLOSURE STATEMENT AND CERTIFICATION

_____, surety(ies) on the attached bond, hereby certifies(y) the following:

- (1) The surety meets the applicable capital and surplus requirements of R.S. 17:17-6 or R.S. 17:17-7 as of the surety's most current annual filing with the New Jersey Department of Insurance.
- (2) The capital (where applicable) and surplus, as determined in accordance with the applicable laws of the State of New Jersey, of the surety(ies) participating in the issuance of the attached bond is (are) in the following amount(s) as of the calendar year ending December 31, _____, (insert most recent calendar year for which capital and surplus amounts are available), which amounts have been certified as indicated by certified public accountants (indicating separately for each surety that surety's capital and surplus amounts, together with the name and address of the firm of certified public accountants that shall have certified those amounts):

- (3) (a) With respect to each surety participating in the issuance of the attached bond that has received from the United States Secretary of the Treasury a certificate of authority pursuant to 31 U.S.C. 9305, the underwriting limitation established therein and the date as of which that limitation was effective is as follows (indicating for each surety that surety's underwriting limitation and the effective date thereof):

- (b) With respect to each surety participating in the issuance of the attached bond that has not received such a certificate of authority from the United States Secretary of the Treasury, the underwriting limitation of that surety as established pursuant to R.S. 17:18-9 as of date on which such limitation was so established, is as follows (indicating for each such surety that surety's underwriting limitation and the date on which that limitation was established):

- (4) The amount of the bond to which this statement and certification is attached is \$_____.

- (5) If, by virtue of one or more contracts of reinsurance, the amount of the bond indicated under item (4) above exceeds the total underwriting limitation of all sureties on the bond as set forth in items (3) (a) or (3) (b) above, or both, then for each such contract of reinsurance:

- (a) The name and address of each such re-insurer under that contract and the amount of that re-insurer's participation in the contract is as follows:

-
-
- (b) Each surety that is party to any such contract of reinsurance certifies that each reinsurer listed under item (5) (a) satisfies the credit for reinsurance requirement established under P.L. 1993, c. 243 (C. 17:51B-1 *et seq.*) and any applicable regulations in effect as of the date on which the bond to which this statement certification is attached shall have been filed with the appropriate public agency.

CERTIFICATION

(to be completed by an authorized certifying agent for each surety on the bond)

I, _____ (name of agent), as _____ (title of agent)

for _____ (name of surety),

a corporation/mutual insurance company/other (indicate type of business organization by circling one) domiciled in _____ (state of domicile), DO HEREBY CERTIFY that, to the best of my knowledge, the foregoing statements made by me are true, and ACKNOWLEDGE that, if any of those statements are false, this bond is VOID and I am subject to punishment.

(Signature of certifying agent)

(Printed name of certifying agent)

(Title of certifying agent)

(Date of Certification)

MANDATORY EQUAL EMPLOYMENT OPPORTUNITY LANGUAGE
N.J.S.A. 10:5-31 et seq. (P.L. 1975, C. 127)
N.J.A.C. 17:27

CONSTRUCTION CONTRACTS

During the performance of this contract, the contractor agrees as follows:

The contractor or subcontractor, where applicable, will not discriminate against any employee or applicant for employment because of age, race, creed, color, national origin, ancestry, marital status, affectional or sexual orientation, gender identity or expression, disability, nationality or sex. Except with respect to affectional or sexual orientation and gender identity or expression, the contractor will ensure that equal employment opportunity is afforded to such applicants in recruitment and employment, and that employees are treated during employment, without regard to their age, race, creed, color, national origin, ancestry, marital status, affectional or sexual orientation, gender identity or expression, disability, nationality or sex. Such equal employment opportunity shall include, but not be limited to the following: employment, up-grading, demotion, or transfer; recruitment or recruitment advertising; layoff or termination; rates of pay or other forms of compensation; and selection for training, including apprenticeship. The contractor agrees to post in conspicuous places, available to employees and applicants for employment, notices to be provided by the Public Agency Compliance Officer setting forth provisions of this nondiscrimination clause.

The contractor or subcontractor, where applicable will, in all solicitations or advertisements for employees placed by or on behalf of the contractor, state that all qualified applicants will receive consideration for employment without regard to age, race, creed, color, national origin, ancestry, marital status, affectional or sexual orientation, gender identity or expression, disability, nationality or sex.

The contractor or subcontractor will send to each labor union, with which it has a collective bargaining agreement, a notice, to be provided by the agency contracting officer, advising the labor union or workers' representative of the contractor's commitments under this act and shall post copies of the notice in conspicuous places available to employees and applicants for employment.

The contractor or subcontractor, where applicable, agrees to comply with any regulations promulgated by the Treasurer, pursuant to N.J.S.A. 10:5-31 et seq., as amended and supplemented from time to time and the Americans with Disabilities Act.

When hiring or scheduling workers in each construction trade, the contractor or subcontractor agrees to make good faith efforts to employ minority and women workers in each construction trade consistent with the targeted employment goal prescribed by N.J.A.C. 17:27-7.2; provided, however, that the Dept. of LWD, Construction EEO Monitoring Program may, in its discretion, exempt a contractor or subcontractor from compliance with the good faith procedures prescribed by the following provisions, A, B and C, as long as the Dept. of LWD, Construction EEO Monitoring Program is satisfied that the contractor or subcontractor is employing workers provided by a union which provides evidence, in accordance with standards prescribed by the Dept. of LWD, Construction EEO Monitoring Program, that its percentage of active "card carrying" members who are minority and women workers is equal to or greater than the targeted employment goal established in accordance with N.J.A.C. 17:27-7.2. The contractor or subcontractor agrees that a good faith effort shall include compliance with the following procedures:

(A) If the contractor or subcontractor has a referral agreement or arrangement with a union for a construction trade, the contractor or subcontractor shall, within three business days of the contract award, seek assurances from the union that it will cooperate with the contractor or subcontractor as it fulfills its affirmative action obligations under this contract and in accordance with the rules promulgated by the Treasurer pursuant to N.J.S.A. 10:5-31 et. seq., as supplemented and amended from time to time and the Americans with Disabilities Act. If the contractor or subcontractor is unable to obtain said assurances from the construction trade union at least five business days prior to the commencement of construction work, the contractor or subcontractor agrees to afford equal employment opportunities minority and women workers directly, consistent with this chapter. If the contractor's or subcontractor's prior experience with a construction trade union, regardless of whether the union has provided said assurances, indicates a significant possibility that the trade union will not refer sufficient minority and women workers consistent with affording equal employment opportunities as specified in this chapter, the contractor or subcontractor agrees to be prepared to provide such opportunities to minority and women workers directly, consistent with this chapter, by complying with the hiring or scheduling procedures prescribed under (B) below; and the contractor or subcontractor further agrees to take said action immediately if it determines that the union is not referring minority and women workers consistent with the equal employment opportunity goals set forth in this chapter.

(B) If good faith efforts to meet targeted employment goals have not or cannot be met for each construction trade by adhering to the procedures of (A) above, or if the contractor does not have a referral agreement or arrangement with a union for a construction trade, the contractor or subcontractor agrees to take the following actions:

(1) To notify the public agency compliance officer, the Dept. of LWD, Construction EEO Monitoring Program, and minority and women referral organizations listed by the Division pursuant to N.J.A.C. 17:27-5.3, of its workforce needs, and request referral of minority and women workers;

(2) To notify any minority and women workers who have been listed with it as awaiting available vacancies;

(3) Prior to commencement of work, to request that the local construction trade union refer minority and women workers to fill job openings, provided the contractor or subcontractor has a referral agreement or arrangement with a union for the construction trade;

(4) To leave standing requests for additional referral to minority and women workers with the local construction trade union, provided the contractor or subcontractor has a referral agreement or arrangement with a union for the construction trade, the State Training and Employment Service and other approved referral sources in the area;

(5) If it is necessary to lay off some of the workers in a given trade on the construction site, layoffs shall be conducted in compliance with the equal employment opportunity and non-discrimination standards set forth in this regulation, as well as with applicable Federal and State court decisions;

(6) To adhere to the following procedure when minority and women workers apply or are referred to the contractor or subcontractor:

(i) The contractor or subcontractor shall interview the referred minority or women worker.

(ii) If said individuals have never previously received any document or certification signifying a level of qualification lower than that required in order to perform the work of the construction trade, the contractor or subcontractor shall in good faith determine the qualifications of such individuals. The contractor or subcontractor shall hire or schedule those individuals who satisfy appropriate qualification standards in conformity with the equal employment opportunity and non-discrimination principles set forth in this chapter. However, a contractor or subcontractor shall determine that the individual at least possesses the requisite skills, and experience recognized by a union, apprentice program or a referral agency, provided the referral agency is acceptable to the Dept. of LWD, Construction EEO Monitoring Program. If necessary, the contractor or subcontractor shall hire or schedule minority and women workers who qualify as trainees pursuant to these rules. All of the requirements, however, are limited by the provisions of (C) below.

(iii) The name of any interested women or minority individual shall be maintained on a waiting list, and shall be considered for employment as described in (i) above, whenever vacancies occur. At the request of the Dept. of LWD, Construction EEO Monitoring Program, the contractor or subcontractor shall provide evidence of its good faith efforts to employ women and minorities from the list to fill vacancies.

(iv) If, for any reason, said contractor or subcontractor determines that a minority individual or a woman is not qualified or if the individual qualifies as an advanced trainee or apprentice, the contractor or subcontractor shall inform the individual in writing of the reasons for the determination, maintain a copy of the determination in its files, and send a copy to the public agency compliance officer and to the Dept. of LWD, Construction EEO Monitoring Program.

(7) To keep a complete and accurate record of all requests made for the referral of workers in any trade covered by the contract, on forms made available by the Dept. of LWD, Construction EEO Monitoring Program and submitted promptly to the Dept. of LWD, Construction EEO Monitoring Program upon request.

(C) The contractor or subcontractor agrees that nothing contained in (B) above shall preclude the contractor or subcontractor from complying with the union hiring hall or apprenticeship policies in any applicable collective bargaining agreement or union hiring hall arrangement, and, where required by custom or agreement, it shall send journeymen and trainees to the union for referral, or to the apprenticeship program for admission, pursuant to such agreement or arrangement. However, where the practices of a union or apprenticeship program will result in the exclusion of minorities and women or the failure to refer minorities and women consistent with the targeted county employment goal, the contractor or subcontractor shall consider for employment persons referred pursuant to (B) above without regard to such agreement or arrangement; provided further, however, that the contractor or subcontractor shall not be required to employ women and minority advanced trainees and trainees in numbers which result in the employment of advanced trainees and trainees as a percentage of the total workforce for the construction trade, which percentage significantly exceeds the apprentice to journey worker ratio specified in the applicable collective bargaining agreement, or in the absence of a collective bargaining agreement, exceeds the ratio established by practice in the area for said construction trade. Also, the contractor or subcontractor agrees that, in implementing the procedures of (B) above, it shall, where applicable, employ minority and women workers residing within the geographical jurisdiction of the union.

After notification of award, but prior to signing a construction contract, the contractor shall submit to the public agency compliance officer and the Dept. of LWD, Construction EEO Monitoring Program an initial project workforce report (Form AA 201) electronically provided to the public agency by the Dept. of LWD, Construction EEO Monitoring Program, through its website, for distribution to and completion by the contractor, in accordance with N.J.A.C. 17:27-7. The contractor also agrees to submit a copy of the Monthly Project Workforce Report once a month thereafter for the duration of this contract to the Division and to the public agency compliance officer.

The contractor agrees to cooperate with the public agency in the payment of budgeted funds, as is necessary, for on-the-job and/or off-the-job programs for outreach and training of minorities and women.

(D) The contractor and its subcontractors shall furnish such reports or other documents to the Dept. of LWD, Construction EEO Monitoring Program as may be requested by the Dept. of LWD, Construction EEO Monitoring Program from time to time in order to carry out the purposes of these regulations, and public agencies shall furnish such information as may be requested by the Dept. of LWD, Construction EEO Monitoring Program for conducting a compliance investigation pursuant to **Subchapter 10 of the Administrative Code (NJAC 17:27-1.1 et seq).**

IF AWARDED A CONTRACT YOUR COMPANY/FIRM WILL BE REQUIRED TO COMPLY WITH THE AFFIRMATIVE ACTION REQUIREMENTS LISTED ABOVE.

Firm Name: _____

Signature: _____

Title: _____

Date: _____

Additional Mandatory Construction Contract Language For State Agencies, Independent Authorities, Colleges and Universities Only

The Executive Order No. 151 (Corzine, August 28, 2009) and P.L. 2009, Chapter 335 include a provision which require all state agencies, independent authorities and colleges and universities to include additional mandatory equal employment and affirmative action language in its construction contracts. It is important to note that this language is in addition to and does not replace the mandatory contract language and good faith efforts requirements for construction contracts required by N.J.A.C. 17:27-3.6, 3.7 and 3.8. The additional mandatory equal employment and affirmative action language is as follows:

It is the policy of the **[Reporting Agency]** that its contracts should create a workforce that reflects the diversity of the State of New Jersey. Therefore, contractors engaged by the **[Reporting Agency]** to perform under a construction contract shall put forth a good faith effort to engage in recruitment and employment practices that further the goal of fostering equal opportunities to minorities and women.

The contractor must demonstrate to the **[Reporting Agency]**'s satisfaction that a good faith effort was made to ensure that minorities and women have been afforded equal opportunity to gain employment under the **[Reporting Agency]**'s contract with the contractor. Payment may be withheld from a contractor's contract for failure to comply with these provisions.

Evidence of a "good faith effort" includes, but is not limited to:

1. The Contractor shall recruit prospective employees through the State Job bank website, managed by the Department of Labor and Workforce Development, available online at <http://NJ.gov/JobCentralNJ>;
2. The Contractor shall keep specific records of its efforts, including records of all individuals interviewed and hired, including the specific numbers of minorities and women;
3. The Contractor shall actively solicit and shall provide the **[Reporting Agency]** with proof of solicitations for employment, including but not limited to advertisements in general circulation media, professional service publications and electronic media; and
4. The Contractor shall provide evidence of efforts described at 2 above to the **[Reporting Agency]** no less frequently than once every 12 months.
5. The Contractor shall comply with the requirements set forth at N.J.A.C. 17:27-1.1 et seq.

To ensure successful implementation of the Executive Order and Law, state agencies, independent authorities and colleges and universities must forward an Initial Project Workforce Report (AA 201) for any projects funded with ARRA money to the Dept. of LWD, Construction EEO Monitoring Program immediately upon notification of award but prior to execution of the contract.



STATEMENT OF OWNERSHIP DISCLOSURE

N.J.S.A. 52:25-24.2 (P.L. 1977, c.33, as amended by P.L. 2016, c.43)

This statement shall be completed, certified to, and included with all bid and proposal submissions. Failure to submit the required information is cause for automatic rejection of the bid or proposal.

Name of Organization: _____

Organization Address: _____

Part I Check the box that represents the type of business organization:

- Sole Proprietorship (skip Parts II and III, execute certification in Part IV)
- Non-Profit Corporation (skip Parts II and III, execute certification in Part IV)
- For-Profit Corporation (any type) Limited Liability Company (LLC)
- Partnership Limited Partnership Limited Liability Partnership (LLP)
- Other (be specific): _____

Part II

The list below contains the names and addresses of all stockholders in the corporation who own 10 percent or more of its stock, of any class, or of all individual partners in the partnership who own a 10 percent or greater interest therein, or of all members in the limited liability company who own a 10 percent or greater interest therein, as the case may be. **(COMPLETE THE LIST BELOW IN THIS SECTION)**

OR

No one stockholder in the corporation owns 10 percent or more of its stock, of any class, or no individual partner in the partnership owns a 10 percent or greater interest therein, or no member in the limited liability company owns a 10 percent or greater interest therein, as the case may be. **(SKIP TO PART IV)**

(Please attach additional sheets if more space is needed):

| Name of Individual or Business Entity | Home Address (for Individuals) or Business Address |
|---------------------------------------|--|
| | |
| | |
| | |

| | |
|--|--|
| | |
|--|--|

Part III DISCLOSURE OF 10% OR GREATER OWNERSHIP IN THE STOCKHOLDERS, PARTNERS OR LLC MEMBERS LISTED IN PART II

If a bidder has a direct or indirect parent entity which is publicly traded, and any person holds a 10 percent or greater beneficial interest in the publicly traded parent entity as of the last annual federal Security and Exchange Commission (SEC) or foreign equivalent filing, ownership disclosure can be met by providing links to the website(s) containing the last annual filing(s) with the federal Securities and Exchange Commission (or foreign equivalent) that contain the name and address of each person holding a 10% or greater beneficial interest in the publicly traded parent entity, along with the relevant page numbers of the filing(s) that contain the information on each such person. **Attach additional sheets if more space is needed.**

| Website (URL) containing the last annual SEC (or foreign equivalent) filing | Page #'s |
|---|----------|
| | |
| | |
| | |

Please list the names and addresses of each stockholder, partner or member owning a 10 percent or greater interest in any corresponding corporation, partnership and/or limited liability company (LLC) listed in Part II **other than for any publicly traded parent entities referenced above.** The disclosure shall be continued until names and addresses of every noncorporate stockholder, and individual partner, and member exceeding the 10 percent ownership criteria established pursuant to N.J.S.A. 52:25-24.2 has been listed. **Attach additional sheets if more space is needed.**

| Stockholder/Partner/Member and Corresponding Entity Listed in Part II | Home Address (for Individuals) or Business Address |
|---|--|
| | |
| | |
| | |

Part IV Certification

I, being duly sworn upon my oath, hereby represent that the foregoing information and any attachments thereto to the best of my knowledge are true and complete. I acknowledge: that I am authorized to execute this certification on behalf of the bidder/proposer; that the **The College of New Jersey** is relying on the information contained herein and that I am under a continuing obligation from the date of this certification through the completion of any contracts with **The College of New Jersey** to notify the **The College of New Jersey** in writing of any changes to the information contained herein; that I am aware that it is a criminal offense to make a false statement or misrepresentation in this certification, and if I do so, I am subject to criminal prosecution under the law and that it will constitute a material breach of my agreement(s) with the, permitting the **The College of New Jersey** to declare any contract(s) resulting from this certification void and unenforceable.

| | | | |
|--------------------|--|--------|--|
| Full Name (Print): | | Title: | |
| Signature: | | Date: | |



NON-COLLUSION STATEMENT

Date: _____

The College of New Jersey
The Office of Budget and Finance, Department of Purchasing
Administrative Services Building, Room 201
P.O. Box 7718
Ewing, New Jersey 08628-0718

To Whom It May Concern:

This is to certify that the undersigned bidder _____ as not, either directly or indirectly, entered into any agreement, participated in any collusion, or otherwise taken any action in restraint of free competitive bidding in connection with the proposal submitted to The College of New Jersey on the _____ day of _____, 20_____.

Signature: _____

Corporate Seal:

Attest by: _____

Sworn to and subscribed before me this _____ day of _____, 20_____.

My commission Expires: _____

Notary Public

THIS STATEMENT MUST BE COMPLETED AND SIGNED

INFORMATION AND INSTRUCTIONS

For Completing the “Two-Year Vendor Certification and Disclosure of Political Contributions” Chapter 51 Form

Background Information

On September 22, 2004, then-Governor James E. McGreevey issued E.O. 134, the purpose of which was to insulate the negotiation and award of State contracts from political contributions that posed a risk of improper influence, purchase of access or the appearance thereof. To this end, E.O. 134 prohibited State departments, agencies and authorities from entering into contracts exceeding \$17,500 with individuals or entities that made certain political contributions. E.O. 134 was superseded by Public Law 2005, c. 51, signed into law on March 22, 2005 (“Chapter 51”).

On September 24, 2008, Governor Jon S. Corzine issued E.O. 117 which is designed to enhance New Jersey’s efforts to protect the integrity of procurement decisions and increase the public’s confidence in government. The Executive Order builds upon the provisions of Chapter 51.

Two-Year Certification Process

Upon approval by the State Chapter 51 Review Unit, the Certification and Disclosure of Political Contributions form is valid for a two (2) year period. Thus, if a vendor receives approval on January 1, 2014, the certification expiration date would be December 31, 2015. Any change in the vendor’s ownership status and/or political contributions during the two-year period will require the submission of new Chapter 51/Executive Order 117 forms to the State Review Unit. **Please note that it is the vendor’s responsibility to file new forms with the State should these changes occur.**

State Agency Instructions: Prior to the awarding of a contract, the State Agency should first use NJSTART (<https://www.njstart.gov/bsol/>) to check the status of a vendor’s Chapter 51 certification before contacting the Review Unit’s mailbox at CD134@treas.nj.gov. If the State Agency does not find any Chapter 51 Certification information in NJSTART and/or the vendor is not registered in NJSTART, then the State Agency should send an e-mail to CD134@treas.nj.gov to verify the certification status of the vendor. If the response is that the vendor is NOT within an approved two-year period, then forms must be obtained from the vendor and forwarded for review. If the response is that the vendor is within an approved two-year period, then the response so stating should be placed with the bid/contract documentation for the subject project.

Instructions for Completing the Form

Part 1: BUSINESS ENTITY INFORMATION

Business Name – Enter the full legal name of the vendor, including trade name if applicable.

Address, City, State, Zip and Phone Number -- Enter the vendor's street address, city, state, zip code and telephone number.

Vendor Email – Enter the vendor’s primary email address.

Vendor FEIN – Please enter the vendor’s Federal Employment Identification Number.

Business Type - Check the appropriate box that represents the vendor's type of business formation.

Listing of officers, shareholders, partners or members - Based on the box checked for the business type, provide the corresponding information. (A complete list must be provided.)

Part 2: DISCLOSURE OF CONTRIBUTIONS

Read the three types of political contributions that require disclosure and, if applicable, provide the recipient's information. The definition of "Business Entity/Vendor" and "Contribution" can be found on pages 3 and 4 of this form.

Name of Recipient - Enter the full legal name of the recipient.

Address of Recipient - Enter the recipient's street address.

Date of Contribution - Indicate the date the contribution was given.

Amount of Contribution - Enter the dollar amount of the contribution.

Type of Contribution - Select the type of contribution from the examples given.

Contributor's Name - Enter the full name of the contributor.

Relationship of the Contributor to the Vendor - Indicate the relationship of the contributor to the vendor. (e.g. officer or shareholder of the company, partner, member, parent company of the vendor, subsidiary of the vendor, etc.)

NOTE: If form is being completed electronically, click "Add a Contribution" to enter additional contributions. Otherwise, please attach additional pages as necessary.

Check the box under the recipient information if no reportable contributions have been solicited or made by the business entity. **This box must be checked if there are no contributions to report.**

Part 3: CERTIFICATION

Check Box A if the representative completing the Certification and Disclosure form is doing so on behalf of the business entity and all individuals and/or entities whose contributions are attributable to the business entity.

(No additional Certification and Disclosure forms are required if BOX A is checked.)

Check Box B if the representative completing the Certification and Disclosure form is doing so on behalf of the business entity and all individuals and/or entities whose contributions are attributable to the business entity with the exception of those individuals and/or entities that submit their own separate form. For example, the representative is not signing on behalf of the vice president of a corporation, but all others. The vice president completes a separate Certification and Disclosure form. **(Additional Certification and Disclosure forms are required from those individuals and/or entities that the representative is not signing on behalf of and are included with the business entity's submittal.)**

Check Box C if the representative completing the Certification and Disclosure form is doing so on behalf of the business entity only. **(Additional Certification and Disclosure forms are required from all individuals and/or entities whose contributions are attributable to the business entity and must be included with the business entity submittal.)**

Check Box D when a sole proprietor is completing the Certification and Disclosure form or when an individual or entity whose contributions are attributable to the business entity is completing a separate Certification and Disclosure form.

Read the five statements of certification prior to signing.

The representative authorized to complete the Certification and Disclosure form must sign and print her/his name, title or position and enter the date.

State Agency Procedure for Submitting Form(s)

The State Agency should submit the completed and signed Two-Year Vendor Certification and Disclosure forms either electronically to: cd134@treas.nj.gov or regular mail at: Chapter 51 Review Unit, P.O. Box 230, 33 West State Street, Trenton, NJ 08625-0230. Original forms should remain with the State Agency and copies should be sent to the Chapter 51 Review Unit.

Business Entity Procedure for Submitting Form(s)

The business entity should return this form to the contracting State Agency.

The business entity can submit the Certification and Disclosure form directly to the Chapter 51 Review Unit only when:

- The business entity is approaching its two-year certification expiration date and is seeking certification renewal;
- The business entity had a change in its ownership structure; OR
- The business entity made any contributions during the period in which its last two-year certification was in effect, or during the term of a contract with a State Agency.

Questions & Information

Questions regarding Public Law 2005, Chapter 51 (N.J.S.A. 19:44A-20.13) or E.O. 117 (2008) may be submitted electronically through the Division of Purchase and Property website at: <https://www.state.nj.us/treas/purchase/eo134questions.shtml>.

Reference materials and forms are posted on the Political Contributions Compliance website at: <http://www.state.nj.us/treasury/purchase/execorder134.shtml>.



State of New Jersey
Department of the Treasury

Division of Purchase and Property

Two-Year Chapter 51/Executive Order 117 Vendor Certification and
Disclosure of Political Contributions

FOR STATE USE ONLY

Solicitation, RFP, or Contract No. _____ Award Amount _____

Description of Services _____

State Agency Name _____ Contact Person _____

Phone Number _____ Contact Email _____

Check if the Contract / Agreement is Being Funded Using FHWA Funds

**Please check if requesting
recertification**

Part 1: Business Entity Information

Full Legal Business Name _____
(Including trade name if applicable)

Address _____

City _____ State _____ Zip _____ Phone _____

Vendor Email _____ Vendor FEIN (SS# if sole proprietor/natural person) _____

**Check off the business type and list below the required information for the type of business selected.
MUST BE COMPLETED IN FULL**

- Corporation: LIST ALL OFFICERS and any 10% and greater shareholder (If the corporation only has one officer, please write "sole officer" after the officer's name.)
- Professional Corporation: LIST ALL OFFICERS and ALL SHAREHOLDERS
- Partnership: LIST ALL PARTNERS with any equity interest
- Limited Liability Company: LIST ALL MEMBERS with any equity interest
- Sole Proprietor

Note: "Officers" means President, Vice President with senior management responsibility, Secretary, Treasurer, Chief Executive Officer or Chief Financial Officer of a corporation, or any person routinely performing such functions for a corporation.

Also Note: "N/A will not be accepted as a valid response. Where applicable, indicate "None."

All Officers of a Corporation or PC

**10% and greater shareholders of a corporation
or all shareholders of a PC**

All Equity partners of a Partnership

All Equity members of a LLC

If you need additional space for listing of Officers, Shareholders, Partners or Members, please attach separate page.

Part 2: Disclosure of Contributions by the business entity or any person or entity whose contributions are attributable to the business entity.

1. Report below all contributions solicited or made during the 4 years immediately preceding the commencement of negotiations or submission of a proposal to any:

Political organization organized under Section 527 of the Internal Revenue Code and which also meets the definition of a continuing political committee as defined in N.J.S.A. 19:44A-3(n)

2. Report below all contributions solicited or made during the 5 ½ years immediately preceding the commencement of negotiations or submission of a proposal to any:

Candidate Committee for or Election Fund of any Gubernatorial or Lieutenant Gubernatorial candidate
State Political Party Committee
County Political Party Committee

3. Report below all contributions solicited or made during the 18 months immediately preceding the commencement of negotiations or submission of a proposal to any:

Municipal Political Party Committee
Legislative Leadership Committee

| |
|---|
| Full Legal Name of Recipient _____ |
| Address of Recipient _____ |
| Date of Contribution _____ Amount of Contribution _____ |
| Type of Contribution (i.e. currency, check, loan, in-kind) _____ |
| Contributor Name _____ |
| Relationship of Contributor to the Vendor _____ |
| If this form is not being completed electronically, please attach additional contributions on separate page. Click the "Add a Contribution" tab to enter additional contributions. |

Remove Contribution

Add a Contribution

Check this box only if no political contributions have been solicited or made by the business entity or any person or entity whose contributions are attributable to the business entity.

Part 3: Certification (Check one box only)

- (A) I am certifying on behalf of the business entity and all individuals and/or entities whose contributions are attributable to the business entity as listed on Page 1 under **Part 1: Vendor Information**.
- (B) I am certifying on behalf of the business entity and all individuals and/or entities whose contributions are attributable to the business entity as listed on Page 1 under **Part 1: Vendor Information**, except for the individuals and/or entities who are submitting separate Certification and Disclosure forms which are included with this submittal.
- (C) I am certifying on behalf of the business entity only; any remaining persons or entities whose contributions are attributable to the business entity (as listed on Page 1) have completed separate Certification and Disclosure forms which are included with this submittal.
- (D) I am certifying as an individual or entity whose contributions are attributable to the business entity.

I hereby certify as follows:

1. I have read the Information and Instructions accompanying this form prior to completing the certification on behalf of the business entity.
2. All reportable contributions made by or attributable to the business entity have been listed above.

3. The business entity has not knowingly solicited or made any contribution of money, pledge of contribution, including in-kind contributions, that would bar the award of a contract to the business entity unless otherwise disclosed above:

- a) Within the 18 months immediately preceding the commencement of negotiations or submission of a proposal for the contract or agreement to:
 - (i) A candidate committee or election fund of any candidate for the public office of Governor or Lieutenant Governor or to a campaign committee or election fund of holder of public office of Governor or Lieutenant Governor; OR
 - (ii) Any State, County or Municipal political party committee; OR
 - (iii) Any Legislative Leadership committee.
- b) During the term of office of the current Governor or Lieutenant Governor to:
 - (i) A candidate committee or election fund of a holder of the public office of Governor or Lieutenant Governor; OR
 - (ii) Any State or County political party committee of the political party that nominated the sitting Governor or Lieutenant Governor in the last gubernatorial election.
- c) Within the 18 months immediately preceding the last day of the sitting Governor or Lieutenant Governor's first term of office to:
 - (i) A candidate committee or election fund of the incumbent Governor or Lieutenant Governor; OR
 - (ii) Any State or County political party committee of the political party that nominated the sitting Governor or Lieutenant Governor in the last gubernatorial election.

4. During the term of the contract/agreement the business entity has a continuing responsibility to report, by submitting a new Certification and Disclosure form, any contribution it solicits or makes to:

- (a) Any candidate committee or election fund of any candidate or holder of the public office of Governor or Lieutenant Governor; OR
- (b) Any State, County or Municipal political party committee; OR
- (c) Any Legislative Leadership committee.

The business entity further acknowledges that contributions solicited or made during the term of the contract/agreement may be determined to be a material breach of the contract/agreement.

5. During the two-year certification period the business entity will report any changes in its ownership structure (including the appointment of an officer within a corporation) by submitting a new Certification and Disclosure form indicating the new owner(s) and reporting said owner(s) contributions.

I certify that the foregoing statements in Parts 1, 2 and 3 are true. I am aware that if any of the statements are willfully false, I may be subject to punishment.

Signed Name _____ Print Name _____

Title/Position _____ Date _____

Procedure for Submitting Form(s)

The contracting State Agency should submit this form to the Chapter 51 Review Unit when it has been required as part of a contracting process. The contracting State Agency should submit a copy of the completed and signed form(s), to the Chapter 51 Unit and retain the original for their records.

The business entity should return this form to the contracting State Agency. The business entity can submit this form directly to the Chapter 51 Review Unit only when it -

- Is approaching its two-year certification expiration date and wishes to renew certification;
- Had a change in its ownership structure; OR
- Made any contributions during the period in which its last two-year certification was in effect, or during the term of a contract with a State Agency.

Forms should be submitted either electronically to: cd134@treas.nj.gov , or regular mail at: Chapter 51 Review Unit, P.O. Box 230, 33 West State Street, Trenton, NJ 08625.

State of New Jersey

DISCLOSURE OF INVESTMENT ACTIVITIES IN IRAN

Solicitation Number: Bidder/Offeror:

Pursuant to Public Law 2012, c. 25, any person or entity that submits a bid or proposal or otherwise proposes to enter into or renew a contract must complete the certification below to attest, under penalty of perjury, that the person or entity, or one of the person or entity's parents, subsidiaries, or affiliates, is not identified on a list created and maintained by the Department of the Treasury as a person or entity engaging in investment activities in Iran.

I certify, pursuant to Public Law 2012, c. 25, that the person or entity listed above for which I am authorized to bid/renew:

- is not providing goods or services of \$20,000,000 or more in the energy sector of Iran, including a person or entity that provides oil or liquefied natural gas tankers, or products used to construct or maintain pipelines used to transport oil or liquefied natural gas, for the energy sector of Iran, AND
is not a financial institution that extends \$20,000,000 or more in credit to another person or entity, for 45 days or more, if that person or entity will use the credit to provide goods or services in the energy sector in Iran.

In the event that a person or entity is unable to make the above certification because it or one of its parents, subsidiaries, or affiliates has engaged in the above-referenced activities, a detailed, accurate and precise description of the activities must be provided in part 2 below to the Division of Purchase and Property under penalty of perjury. Failure to provide such will result in the proposal being rendered as non-responsive and appropriate penalties, fines and/or sanctions will be assessed as provided by law.

PART 2: PLEASE PROVIDE FURTHER INFORMATION RELATED TO INVESTMENT ACTIVITIES IN IRAN You must provide a detailed, accurate and precise description of the activities of the bidding person/entity, or one of its parents, subsidiaries or affiliates, engaging in the investment activities in Iran outlined above by completing the boxes below.

EACH BOX WILL PROMPT YOU TO PROVIDE INFORMATION RELATIVE TO THE ABOVE QUESTIONS. PLEASE PROVIDE THOROUGH ANSWERS TO EACH QUESTION. IF YOU NEED TO MAKE ADDITIONAL ENTRIES, PLEASE ADD AN ADDITIONAL SHEET.

Name Relationship to Bidder/Offeror
Description of Activities
Duration of Engagement Anticipated Cessation Date
Bidder/Offeror Contact Name Contact Phone Number

Certification: I, being duly sworn upon my oath, hereby represent and state that the foregoing information and any attachments thereto to the best of my knowledge are true and complete. I attest that I am authorized to execute this certification on behalf of the above-referenced person or entity. I acknowledge that the State of New Jersey is relying on the information contained herein and thereby acknowledge that I am under a continuing obligation from the date of this certification through the completion of any contracts with the State to notify the State in writing of any changes to the answers of information contained herein. I acknowledge that I am aware that it is a criminal offense to make a false statement or misrepresentation in this certification, and if I do so, I recognize that I am subject to criminal prosecution under the law and that it will also constitute a material breach of my agreement(s) with the State of New Jersey and that the State at its option may declare any contract(s) resulting from this certification void and unenforceable.

Full Name (Print): Signature:

Title: Date:



VENDOR QUALIFICATION SHEETS

Vendors are requested to submit evidence of qualifications to meet all requirements as required by the Office of Finance & Business Services at The College of New Jersey by providing the information listed below.

If this information is being requested as part of an RFP or RFQ, vendors may be requested to furnish additional information for clarification purposes. This will in no way change the vendor's original proposal.

TO BE COMPLETED BY VENDOR

1. Please list the types of commodities that your company can provide.

A.

B.

C.

2. The number of years your firm has been providing these services. _____ Year(s)

3. Location of vendor's office that will be responsible for managing contract/service:

Name: _____

Telephone: _____ Fax: _____

Email Address: _____

Street Address: _____

City/State/Zip: _____

Federal Identification Number: _____

4. Address where all purchase orders and payment are to be mailed by users of any contract(s) resulting from this proposal (if different from above).

Purchase Orders:

Firm Name: _____

Street Address: _____

City/State/Zip: _____

Remittances:

Firm Name: _____

Street Address: _____

City/State/Zip: _____

VENDOR QUALIFICATIONS- continued

5. Name of insurance company:

Street Address: _____

City/State/Zip: _____

Types of Insurance: _____

6. Name of individual to contact for sales/services information:

Name: _____

Telephone: _____

Email Address: _____

Street Address: _____

City/State/Zip: _____

7. List the names and titles of personnel who will service this contract:

8. Is your firm registered with the Secretary of State of New Jersey? **Yes** ____ **No** ____

9. Is your firm incorporated? **Yes** ____ **No** ____

A) In What State? _____

10. Is your firm considered a small business in the State of New Jersey? **If yes, please attach a certificate or certification statement from the New Jersey Commerce and Economic Growth Commission.** If no and you would like to register, please contact the New Jersey Commerce and Economic Growth Commission at 609-777-0885.

Small Business: **Yes** ____ **No** ____

A) What category does your firm fall under?

Gross Revenues do not exceed \$500,000 _____

Gross Revenues do not exceed \$5 million _____

Gross Revenues do not exceed \$12 million _____

Under Executive Order 34, TCNJ is responsible for soliciting demographic information from its vendors. TCNJ is required to seek the following information from each firm under contract with us:

1. Is more than fifty percent (50%) of your company minority owned? (circle one) YES NO
(African-American, Hispanic, Asian, and/or Native American)

2. Is more than fifty percent (50%) of your company woman owned? (circle one) YES NO

3. What is the ethnicity of the owner of your company: (check applicable according to 51% ownership)
 - ... Asian American
 - ... Multiple Ethnicities
 - ... Non-Minority
 - ... Hispanic American
 - ... African American
 - ... Caucasian American Female
 - ... Native American
 - ... Unspecified

TCNJ is required to solicit the foregoing information. Your response, however, is **strictly voluntary**. Please be advised that any contracting decisions made by TCNJ will **not** be influenced in any way by your decision to provide the above information.

EXECUTIVE ORDER #34: MINORITY AND WOMEN BUSINESS ENTERPRISES

On September 15, 2006, Governor Corzine signed Executive Order 34 establishing a Division of Minority and Women Business Development. The Division is charged with administering and monitoring policies, practices, and programs to ensure that New Jersey owned minority and women business enterprises (MWBE) are afforded an equal opportunity to participate in New Jersey's purchasing and procurement processes.

State entities are required to report to the Division the ethnic and gender composition of the vendors with which we do business.

VENDOR QUALIFICATIONS-

11. Please provide a list of former or present clients. Also, indicate the name of a contact person and telephone number for reference purposes. **Any personnel from The College of New Jersey listed as a reference will not be considered a valid reference.**

- A. **Client Name:**

 Contact Name:

 Telephone Number:

 Fax Number:

 Email Address:

- B. **Client Name:**

 Contact Name:

Telephone Number:

Fax Number:

Email Address:

C. Client Name:

Contact Name:

Telephone Number:

Fax Number:

Email Address:

D. Client Name:

Contact Name:

Telephone Number:

Fax Number:

Email Address:

VENDOR QUALIFICATIONS- continued

12. Please answer the following questions related to your prior experience:

- a. Has the bidder been found, through either court adjudication, arbitration, mediation, or other contractually stipulated alternate dispute resolution mechanism, to have: failed to provide or perform goods or services; or failed to complete the contract in a timely manner; or otherwise performed unsatisfactorily under a prior contract with the contracting unit? If yes, attach summary of details on a separate sheet.

Yes _____ No _____

- b. Has the bidder defaulted on a contract, thereby requiring the local unit to utilize the services of another contractor to provide the goods or perform the services or to correct or complete the contract? If yes, attach summary of details on a separate sheet.

Yes _____ No _____

- c. Has the bidder defaulted on a contract, thereby requiring the local unit to look to the bidder's surety for completion of the contract or tender of the costs of completion? If yes, attach summary of details on a separate sheet.

Yes _____ No _____

- d. Has the bidder been debarred or suspended from contracting with any of the agencies or departments of the executive branch of the State of New Jersey at the time of contract award, whether or not the action was based on experience with the contracting unit. If yes, attach summary of details on a separate sheet.

Yes _____ No _____

Firm Name: _____

Signature: _____

Title: _____

Date: _____



CONTRACT FOR CONSTRUCTION

This AGREEMENT is entered into as of the ____ day of _____, _____, between

The College: The College of New Jersey (“TCNJ” or the “College”)
PO Box 7718
2000 Pennington Road
Ewing, New Jersey 08628-0718

and

the Contractor: _____ (the “Contractor”)

in connection with

the Project: E-Layer for Field Hockey Lacrosse Turf Field (the “Project”)

The Architect: _____

ARTICLE 1

EMPLOYMENT OF THE CONTRACTOR/THE PROJECT DESCRIPTION

1.1 The College employs the Contractor and the Contractor agrees to perform the construction for the Project identified above. The Project is described in more detail in the College’s Plans and Specifications prepared by the Architect.

ARTICLE 2

THE CONTRACT DOCUMENTS

2.1 The Contract Documents consist of this Contract for Construction and the Exhibits attached hereto (“Contract for Construction”), the General Conditions of the Contract for Construction (the “General Conditions”) (and any other General, Supplementary and other Conditions), the Plans and Specifications, and also the following documents:

- (a) The Contractor's Bid excluding limitations and qualifications unless such limitation or qualification is specifically accepted in writing by the College;
- (c) Addenda and Clarifications issued before the bid due date;
- (d) The Project Bidding Schedule; and
- (e) Modifications issued after execution of this Contract for Construction.

These documents all form the "Contract," and are as fully a part of this Contract as if attached hereto or repeated herein. This Contract represents the entire and integrated agreement between the parties hereto and supersedes prior negotiations, representations or agreements, either written or oral.

ARTICLE 3 **SCOPE OF WORK**

3.1 The Contractor shall fully perform the Work described in the Contract Documents, except as specifically indicated in the Contract Documents to be the responsibility of others. The Contractor shall assume full responsibility for constructing and completing the Project and all the Work, including providing all labor, Subcontractors, materials, equipment, and services reasonably inferable from the Contract Documents and all applicable laws, codes and professional standards, and providing all supervision, management, and scheduling required in the General Conditions and as noted throughout the Contract Documents.

ARTICLE 4 **CONTRACT TIMES**

4.1 TIME OF THE ESSENCE. All dates and durations specified in this Contract, including the Construction Start Date(s), any Milestones Dates, any Substantial Completion Date(s) and any Final Completion Date(s) (collectively, "Contract Times") are agreed to be of the essence.

4.2 CONSTRUCTION START. The Work shall start no later than ten (10) calendar days after the College issues a Notice to Proceed to the Contractor ("Construction Start Date"). If the Work is to be performed in phases, the College may issue a separate Notice to Proceed with respect to each phase (e.g., Phase 1 Notice to Proceed, Phase 2 Notice to Proceed, etc.) thereby establishing different Construction Start Dates for each phase (e.g., Phase 1 Construction Start Date, Phase 2 Construction Start Date, etc.). The College may, in its sole discretion and at no cost to the College, choose to delay the issuance of a Notice to Proceed and the Construction Start Date for any phase until after the Contractor has achieved Substantial or Final Completion of any other phase.

4.3 MILESTONES. The construction tasks or activities shall be completed within the number of calendar days after the Construction Start Date as set forth in the Notice to Proceed ("Milestone Dates"). If the Work is to be performed in phases, each phase may have

separate Milestone Dates (e.g., Phase 1 Milestone Dates, Phase 2 Milestone Dates, etc.), which dates shall be set forth in the Notice to Proceed for that phase.

44 SUBSTANTIAL COMPLETION. The Contractor shall diligently prosecute the Work and shall achieve Substantial Completion of the entire Work as set forth in the Notice to Proceed (“Substantial Completion Date”). If the Work is to be performed in phases, each phase may have a separate Substantial Completion Date (e.g., Phase 1 Substantial Completion Date, Phase 2 Substantial Completion Date, etc.), which date shall be set forth in the Notice to Proceed for that phase. The definition and requirements of Substantial Completion are set forth in the General Conditions. The Substantial Completion Date(s) shall only be changed by a written change order.

45 FINAL COMPLETION. The Contractor shall achieve Final Completion of the entire Work as set forth in the Notice to Proceed (“Final Completion Date”). If the Work is to be performed in phases, each phase may have a separate Final Completion Date (e.g., Phase 1 Final Completion Date, Phase 2 Final Completion Date, etc.), which date shall be set forth in the Notice to Proceed for that phase. The requirements for Final Completion are defined in the General Conditions as well as the Specifications of the Project. The Final Completion Date(s) shall only be changed by written change order.

46 LIQUIDATED DAMAGES FOR DELAY. If the Contractor fails to achieve Substantial Completion of a phase of the Work or of the entire Work by the Substantial Completion Date(s) set forth in the applicable Notice to Proceed (as extended by Change Order, if applicable), and the delay is not excused by the College, then the Contractor shall pay the College the following amounts as liquidated damages for delay (“Liquidated Damages”) for each calendar day that the phase of the Work or the entire Work is not substantially completed beyond the applicable Substantial Completion Date:

\$ _____ per calendar day.

The College and the Contractor agree that the actual loss to the College from construction delays and the inability to use the Project or any phase of the Project in a substantially completed state are for the most part difficult to quantify, and that the foregoing Liquidated Damages formula results in damages amounts that are a reasonable estimate of the damage to the College for not being able to use the Project in a substantially completed state and are not penalties and are not intended to be penalties. The College may deduct Liquidated Damages from payments due under this Contract, but its failure to withhold Liquidated Damages or to assert a claim for Liquidated Damages shall not be deemed a waiver of the College’s right to withhold or to assert a claim for damages for any delay that occurs at any time on the Project.

ARTICLE 5
CONTRACT PRICE

51 CONTRACT PRICE. The Contractor shall be paid \$_____ for the complete performance of this Contract, which was proposed by the Contractor in its bid and accepted by the College (the "Contract Price"). The Contractor shall be entitled to additional compensation for authorized changes which include the cost of the changes and mark-ups included in change orders approved in writing by the College in accordance with the change order provision set forth in the General Conditions.

52 ALTERNATES. The Contract Price is based upon and includes the following alternates, if any, which are described in the Contract Documents and are hereby accepted by the College:

[_____]

53 UNIT PRICES. The Contract Price is based upon and includes the following unit prices, if any, which are described in the Contract Documents:

[_____]

54 ALLOWANCES. The Contract Price is based upon and includes the following allowances, if any, which are described in the Contract Documents:

[_____]

ARTICLE 6
PAYMENTS TO THE CONTRACTOR

6.1 PAYMENT. The Contractor will be paid by the College in accordance with this Article and the payment provision in the General Conditions.

6.2 MONTHLY PROGRESS PAYMENTS. The College will make progress payments as the Work proceeds based on written invoices submitted monthly by the Contractor and approved by the Architect and the College. No payments will be made until the Contractor submits a unit schedule break down showing the portions of the total Contract Price for each principal category of Work and value loaded CPM schedule allocating the Contract Price among the schedule activities. Monthly progress payment amounts shall be based on the percentages of the Work completed as of the end of the pay period (less earlier payments). All payment requests or invoices and all payments shall be governed by the payment provision of the General Conditions as well as any special requirements of this Contract, including the requirement that progress payments shall be based on a unit schedule breakdown and a value loaded CPM schedule.

6.3 RETAINAGE. The College will retain 2% of the amount due on each progress payment pending Final Completion of the Work. The holding and release of retainage shall be governed by the payment provision of the General Conditions.

6.4 CHANGE ORDERS. The Contractor shall invoice for change order work in the monthly progress payment invoices as the change order work is performed, but only after a written change order and TCNJ issued Purchase Order has been signed by the College. Changes in the Work shall be governed by the change order provision of the General Conditions.

6.5 FINAL PAYMENT. Upon final completion of all Work included in the Contract Documents including all change orders, acceptance of the Work by the Architect and the College, the satisfactory completion of all of the requirements in the General Conditions for final completion, and the issuance of the Certificate of Final Completion, the Contractor will be paid the fully adjusted Contract Price including any retainage withheld (less earlier payments). The invoice for final payment and final payment shall also be subject to the payment provision of the General Conditions and any special requirements of this Contract.

6.6 PAYMENT TERMS. All invoices and payments shall also be subject to the General Conditions, including the provisions regarding payments, to the right of the College to withhold payments or to make deductions from payments, and to the Prevailing Wage Act requirements set forth in the General Conditions. The College will pay proper final invoices within thirty (30) days of their submission to the College with the approval of the Architect.

6.7 SUBMISSION OF INVOICES. Prior to the submission of the invoice, the Contractor will submit to the College and the Architect, in draft form, a “pencil copy” of the monthly invoice for review and approval setting forth each line item for which the Contractor intends to request payment in that invoice based on the claimed percent completed for that line item. Upon receipt of said “pencil copy”, the College and the Architect shall observe the Work in place and, on the basis of such observations, will either approve the amounts requested or modify the Contractor’s request, based on the College’s independent assessment of the Work in place. The College will then return the pencil copy invoice to the Contractor for the Contractor to then adjust and submit the final invoice with the agreed to percentages completed per line item to the College for payment. No invoice shall be submitted for payment until all amounts and completion percentages have been determined in this manner.

6.8 PROMPT PAYMENT ACT. For the purposes of the State’s Prompt Payment Act, N.J.S.A. 2A:30A-1, et seq.:

(a) An invoice will be deemed to have been received when it is received by the College at the address designated in the pre-construction conference for receipt of the invoices.

(b) The “billing date” as that term is used in N.J.S.A. 2A:30A-2 shall be the earlier of the date upon which an invoice for payment is approved for payment or 20 days after the invoice is received, unless within such 20 day period the invoice is found to be incomplete or

otherwise unacceptable and returned to the Contractor, with a written explanation of deficiencies, the amount withheld and the reasons for withholding payment.

(c) In the event that an invoice is found to be deficient and returned to the Contractor, the “billing date” shall be calculated from the date that a corrected invoice is received.

(d) Payment shall be considered to have been made on the date on which a check for such payment is dated.

(e) Payment terms (e.g., “net 20”) offered by the Contractor shall not govern the College’s obligation to make payment.

(f) The following periods of time will not be included in the calculation of the due date of the Contractor’s invoice:

(i) Any time elapsed between receipt of an improper invoice and its return to the Contractor, not to exceed 20 calendar days; or

(ii) Any time elapsed between the College’s return of an improper invoice to the Contractor and the College’s receipt of a corrected invoice.

If the State’s Prompt Payment Act is amended, or the language stated herein is inconsistent with the language contained in the State’s Prompt Payment Act, the language of the State’s Prompt Payment Act shall control.

6.9 LIMITATIONS ON APPLICABILITY. The provisions of this Article shall not govern the College’s payment obligations nor shall they supersede or modify any other contractual provision allowing the withholding of monies from the Contractor to the extent that the Contractor has not performed in accordance with the provisions of the Contract Documents. This Article also shall not govern the College’s payment obligations nor supersede or modify any other contractual provision governing the Contractor claims for additional compensation beyond the base Contract Price and approved change orders.

6.10 INTEREST. Interest shall be payable on amounts due the Contractor if not paid within thirty (30) calendar days after the billing date specified above, as provided under the State’s Prompt Payment Act, N.J.S.A. 2A:30A-1, et seq. Interest on amounts due shall be payable to the Contractor for the period beginning on the day after the required payment date and ending on the date on which the check for payment is drawn. Interest may be paid by separate payment to the Contractor, but shall be paid within 30 days of payment of the principal amount of the approved invoice. Nothing in this Article shall be construed as entitling the Contractor to payment of interest on any sum withheld by the College for any reason permitted under the Contract Documents or applicable law, or on any claim for additional compensation, over and above sums due under the base Contract Price or approved change orders.

ARTICLE 7
DISPUTE RESOLUTION

7.1 If a dispute or claim arises out of or relates to this Contract, or the breach thereof, and if the dispute cannot be settled through negotiation, the method for resolution of such dispute or claim shall be as provided in the dispute resolution provision of the General Conditions.

ARTICLE 8
TERMINATION OR SUSPENSION

81 This Contract may be terminated by the College as provided in the termination and suspension provision in the General Conditions.

82 The Work may be suspended by the College or the Contractor as provided in termination and suspension provision in the General Conditions.

ARTICLE 9
INSURANCE AND BONDS

9.1 CONTRACTOR'S INSURANCE. The Contractor shall purchase and maintain insurance as set forth in the insurance and bonds provision of the General Conditions. To the extent the Contractor shall be required to purchase and maintain additional insurance or insurance that differs from that set forth in the General Conditions, such requirements are set forth below:

[_____]

9.2 SUBCONTRACTOR'S INSURANCE. The Contractor shall ensure that its Subcontractors purchase and maintain insurance as set forth in the insurance and bond provision of the General Conditions.

9.3 PAYMENT AND PERFORMANCE BOND. The Contractor shall furnish the College with a payment bond and a performance bond as set forth in the insurance and bond provision of the General Conditions.

ARTICLE 10
OTHER PROVISIONS

10.1 CONTRACTOR REPRESENTATIONS. The Contractor represents to the College that it has:

(a) **Examination of the Contract Documents.** Examined and carefully studied the Contract Documents and the other documents in the bid documents, and that they are sufficient for performing the Work at the Contract Price.

(b) **Examination of Site.** Visited the site and become familiar with and is satisfied as to the general, local and site conditions that may affect the cost, progress, and performance of the Work.

(c) **Familiarity with Law.** Familiarized itself with all federal, state, and local laws and regulations that may affect the cost, progress, and performance of the Work.

(d) **Familiarity with Other Information and Other Documents.** Carefully studied all reports of investigations and tests of the site and subsurface conditions at or contiguous to the site and all drawings of physical conditions at the site including surface or subsurface composition, water, structures and utilities at or near to the site.

(e) **Additional Information Not Required for Bidding or Contract Performance.** Does not consider that any further examinations, investigations, explorations, tests, studies, or data are necessary for the performance of the Work at the Contract Price.

10.2 ASSIGNMENT OF CONTRACT. The Contractor may not assign this Contract or any rights under or interests in this Contract including its right to payments under this Contract.

10.3 CONTRACTOR PERSONNEL ASSIGNED. The Contractor's team for this Project shall consist of the following personnel, who shall not be reassigned without the College's prior written consent:

| <u>Name</u> | <u>Position</u> |
|-------------|-------------------------------|
| _____ | <u>Project Executive</u> |
| _____ | <u>Project Manager</u> |
| _____ | <u>Project Superintendent</u> |
| _____ | <u>Project Scheduler</u> |

The College reserves the right to request and have any member of the Contractor's or Subcontractor's staff replaced on the Project for any non-discriminatory reason.

10.4 NOTIFICATIONS/AUTHORIZED REPRESENTATIVE. All Notices required under this Contract shall be in writing, signed by the party giving same, and shall be deemed properly given only if hand delivered, sent by reputable overnight courier, or by registered or certified U.S. mail, return receipt requested, postage pre-paid and addressed as provided below.

Notice to the Contractor/Contractor's Representative. Written notices from the College and/or the Architect to the Contractor should be addressed to the Contractor's Representative:

Attn: _____

Notice to the College/College's Representative: Written notices from the Contractor to the College should be addressed to the College's Representative:

The College of New Jersey
PO Box 7718,
Ewing, New Jersey 08628
Attn: _____

with a copy to the College's General Counsel as follows:

Thomas Mahoney, Esq.
Vice President and General Counsel
The College of New Jersey
PO Box 7718
Ewing, NJ 08628-0718

The College's Contracting Officer hereby authorizes the College's Representative to receive all Contract related correspondence.

Notice to the Architect: Written notices from the Contractor to the Architect should be addressed to:

Attn: _____

Neither the College's nor the Contractor's Authorized Representatives shall be changed without 7 days' written notice to the other party.

10.5 CONTRACT TERMS, CHANGES, AND LAW. This Contract constitutes the entire agreement between the College and the Contractor, and it shall be governed by the law of the State of New Jersey. The terms and conditions of this Contract may not be changed except by a writing signed by the Contractor and the College.

10.6 COUNTERPARTS AND SIGNATURES. This Contract may be executed in counterparts. All executed counterparts shall constitute one contract, and each counterpart shall be deemed an original. The parties hereby acknowledge and agree that facsimile signatures or signatures transmitted by electronic mail in so-called “pdf” format shall be legal and binding and shall have the same full force and effect as if an original of this Contract had been delivered. The College and the Contractor (1) intend to be bound by the signatures on any document sent by facsimile or electronic mail, (2) are aware that the other party will rely on such signatures, and (3) hereby waive any defenses to the enforcement of the terms of this Contract based on the foregoing forms of signature.

10.7 NO IMPLIED COVENANTS OR WARRANTIES. The Contractor acknowledges that there are no implied covenants or warranties from the College under this Contract.

10.8 SEVERABILITY. If any term or provision of the Contract Documents are to any extent held invalid or unenforceable, and if the provisions of the Contract Documents that are essential to each party’s interests otherwise remain valid and enforceable, then (i) the remaining terms and provisions in the Contract Documents will not be affected thereby, (ii) each term and provision of the Contract Documents will be valid and enforceable to the fullest extent permitted by law, and (iii) the court/arbitrator(s) will give the offending provision the fullest meaning and effect permitted by law.

10.9 HEADINGS. The headings used in this Contract are for convenience and reference only, and are not part of this Contract, and do not in any way control, define, limit or add to the terms and conditions hereof.

10.10 INTERPRETATION/RULES OF CONSTRUCTION. The parties acknowledge that each party, and if it so chooses, its counsel, have reviewed and revised this Contract and that the normal rule of construction to the effect that any ambiguities be resolved in favor of the non-drafting party shall not be employed in the interpretation of this Contract or any amendments or exhibits thereto.

THE COLLEGE OF NEW JERSEY

By _____
William Rudeau,
Director of Construction

By _____
Lloyd Ricketts,
Vice President and Treasurer

Date _____

Date _____

By _____
Michael Dixon,
Vice President for Facilities Management

By _____
Anup Kapur,
Executive Director of Procurement

Date _____

Date _____

CONTRACTOR:

By _____

Title _____

Date _____



GENERAL CONDITIONS
OF THE
CONTRACT FOR CONSTRUCTION

Last Revised January 2019

TABLE OF CONTENTS

| | Page |
|--|-------------|
| ARTICLE 1 | |
| CONTRACT DOCUMENTS, INTERPRETATION, INFORMATION FOR BIDDERS, CLAIMS BASED ON BID AND CONTRACT DOCUMENTS..... | 1 |
| 1.1 | 1 |
| 1.2 | 3 |
| 1.3 | 3 |
| 1.4 | 3 |
| 1.5 | 4 |
| 1.6 | 4 |
| 1.7 | 4 |
| 1.8 | 5 |
| 1.9 | 5 |
| 1.10 | 5 |
| 1.11 | 5 |
| 1.12 | 5 |
| 1.13 | 6 |
| 1.14 | 6 |
| 1.15 | 6 |
| 1.16 | 6 |
| 1.17 | 7 |
| 1.18 | 7 |
| 1.19 | 7 |
| ARTICLE 2 | |
| THE COLLEGE..... | 8 |
| 2.1 | 8 |
| 2.2 | 8 |
| 2.3 | 9 |
| 2.4 | 9 |
| 2.5 | 9 |
| 2.6 | 9 |
| 2.7 | 10 |
| 2.8 | 11 |
| ARTICLE 3 | |
| THE ARCHITECT | 11 |
| 3.1 | 11 |
| 3.2 | 11 |
| 3.3 | 11 |
| 3.4 | 12 |
| 3.5 | 12 |

TABLE OF CONTENTS
(continued)

| | Page |
|------------------|---|
| 3.6 | The Architect’s Review Of The Contractor’s As-Built Plans. 12 |
| 3.7 | The Architect’s Determination Of Substantial and Final Completion..... 12 |
| ARTICLE 4 | THE CONTRACTOR..... 12 |
| 4.1 | The Contractor’s Responsibility For Performance Of The Contract And Work. 12 |
| 4.2 | The Contractor’s Key Personnel..... 13 |
| 4.3 | The Contractor’s Supervision Of Contract Work/The Superintendent..... 13 |
| 4.4 | Cooperation With The College And Other Contractors. 13 |
| 4.5 | Performance Of The College Directives..... 14 |
| ARTICLE 5 | PERFORMANCE OF WORK..... 15 |
| 5.1 | Protection Of Work/Materials..... 15 |
| 5.2 | Safety And Safety Programs. 15 |
| 5.3 | Emergencies Affecting Safety. 15 |
| 5.4 | Working Hours..... 16 |
| 5.5 | Site Security..... 16 |
| 5.6 | Site Use. 16 |
| 5.7 | Building Access. 16 |
| 5.8 | Minimize Interruption. 16 |
| 5.9 | Submittals (Shop Drawings, Product Data, Samples). 17 |
| 5.10 | Layout And Dimensional Control..... 17 |
| 5.11 | Construction Access, Roads, Walks, And Parking..... 18 |
| 5.12 | Construction Site Condition, Storage, Dust Control..... 18 |
| 5.13 | Photographs..... 18 |
| 5.14 | Project Sign..... 19 |
| 5.15 | Soil Conservation..... 19 |
| 5.16 | Temporary Facilities, Services, Electric, Heat And Enclosures. 19 |
| 5.17 | Substitutions..... 20 |
| 5.18 | License Fees..... 20 |
| ARTICLE 6 | SUBCONTRACTORS 20 |
| 6.1 | The Contractor’s Responsibility For Subcontracted Work..... 20 |
| 6.2 | Subcontractor Identification And Approval..... 21 |
| 6.3 | Subcontractor Qualifications. 21 |
| 6.4 | Subcontractor Compliance With Contract/Subcontractor Supervisors..... 22 |
| 6.5 | No Contractual Relationship Between The College And Subcontractors. 22 |
| 6.6 | Contingent Assignment of Subcontracts..... 22 |

TABLE OF CONTENTS
(continued)

| | Page |
|------------|--|
| ARTICLE 7 | TIME, LIQUIDATED DAMAGES, DELAY CLAIMS AGAINST THE COLLEGE..... 23 |
| 7.1 | Contract Times..... 23 |
| 7.2 | Liquidated Damages For Delay. 23 |
| 7.3 | Delay Claims By The Contractor Against The College -- Limitations. 23 |
| ARTICLE 8 | PROJECT SCHEDULE..... 24 |
| 8.1 | General Project Schedule Requirements..... 24 |
| 8.2 | Form And Content Of Project Schedule. 24 |
| 8.3 | Computerization Of Project Schedule. 26 |
| 8.4 | Weather Inclusion In Project Schedule..... 26 |
| 8.5 | Project Schedule Updates. 26 |
| 8.6 | Meetings/Eight Week Bar Charts. 27 |
| 8.7 | Project Schedule Documentation For Contract Payments..... 27 |
| 8.8 | Progress and Recovery Project Schedules..... 28 |
| 8.9 | The Contractor’s Failure to Provide Project Schedule Updates. 28 |
| 8.10 | Scheduler Qualifications..... 28 |
| ARTICLE 9 | EXTENSIONS, COMPENSATION FOR CERTAIN EXTENSIONS..... 28 |
| 9.1 | Delays Warranting Extensions Of Contract Times..... 28 |
| 9.2 | Weather Delays..... 29 |
| 9.3 | Float Time Use..... 29 |
| 9.4 | Calculation Of Extensions. 29 |
| 9.5 | Elimination of Delays and Extensions (Acceleration)..... 30 |
| 9.6 | Requests For Extensions Required. 30 |
| 9.7 | Compensation For Certain Extensions And Limitations..... 30 |
| ARTICLE 10 | PAYMENTS TO THE CONTRACTOR..... 31 |
| 10.1 | Contract Price..... 31 |
| 10.2 | Monthly Progress Payments. 31 |
| 10.3 | Unit Schedule Breakdown/CPM Activity Price Breakdown..... 32 |
| 10.4 | Invoices For Monthly Progress Payments: Form and Content..... 32 |
| 10.5 | Payment For Materials And Equipment Procured But Not Installed. 33 |
| 10.6 | Retainage..... 34 |
| 10.7 | Payment For Change Order Work. 34 |
| 10.8 | Final Payment. 34 |
| 10.9 | Payment Terms. 34 |
| 10.10 | Payment Based On Partial Acceptance (Limitation). 35 |
| 10.11 | Failure To Pay Amounts In Dispute Not To Affect Performance. 35 |
| 10.12 | Reasons For Withholding Payment. 35 |

TABLE OF CONTENTS
(continued)

| | Page |
|--|-------------|
| 10.13 Set-Off For State Tax Indebtedness..... | 36 |
| 10.14 Maintenance Of Cost And Accounting Records..... | 36 |
| 10.15 Written Evidence of Payment to Subcontractors..... | 37 |
| | |
| ARTICLE 11 CHANGES..... | 37 |
| 11.1 Changes Authorized..... | 37 |
| 11.2 Change Request Or Directive. | 37 |
| 11.3 Change Orders Which Are Protested..... | 38 |
| 11.4 Changes Affecting Contract Times..... | 38 |
| 11.5 Contractor Initiated Change Order Requests. | 38 |
| 11.6 Change Order Amounts. | 39 |
| 11.7 Right To Audit Extra Costs (Before And After Payment)..... | 40 |
| 11.8 Change Orders With Both Price Increases and Decreases..... | 40 |
| 11.9 Waiver Of Rights In Connection With Change Orders Issued Without Protest. | 40 |
| | |
| ARTICLE 12 COMPLETION..... | 40 |
| 12.1 Substantial Completion..... | 40 |
| 12.2 Final Completion. | 41 |
| | |
| ARTICLE 13 SUSPENSION AND TERMINATION OF CONTRACT. | 42 |
| 13.1 Suspension By The College..... | 42 |
| 13.2 Termination For Convenience. | 43 |
| 13.3 Termination For Cause. | 44 |
| 13.4 Surety Takeover Following Termination For Cause. | 45 |
| 13.5 Suspension By The Contractor For Non-Payment..... | 45 |
| | |
| ARTICLE 14 WARRANTY/DEFECTIVE WORK AND MATERIALS..... | 46 |
| 14.1 General Work One Year Warranty; HVAC Systems Two Year Warranty | 46 |
| 14.2 Defective Work, Materials And Equipment. | 47 |
| | |
| ARTICLE 15 INDEMNIFICATION/LIABILITY TO THIRD PARTIES..... | 47 |
| 15.1 The Contractor’s Indemnification Obligation..... | 47 |
| 15.2 The Subcontractor’s Indemnification Obligation. | 49 |
| | |
| ARTICLE 16 INSURANCE AND BONDS. | 49 |
| 16.1 The Contractor’s Insurance..... | 49 |
| 16.2 The Subcontractor’s Insurance. | 51 |
| 16.3 Payment And Performance Bond..... | 51 |

TABLE OF CONTENTS
(continued)

| | Page |
|--|-------------|
| ARTICLE 17 DISPUTE RESOLUTION..... | 51 |
| 17.1 Mediation..... | 51 |
| 17.2 Method Of Binding Dispute Resolution..... | 51 |
| 17.3 Arbitration (If The College Elects To Arbitrate)..... | 51 |
| 17.4 Consolidation Or Joinder..... | 52 |
| 17.5 Work During Pendency Of Dispute..... | 52 |
| 17.6 Prompt Payment Claims..... | 53 |
| 17.7 The Contractor’s Claims: Procedures And Limitations..... | 53 |
| 17.8 Dispute Resolution Process In The Contractor’s Subcontracts..... | 53 |
| | |
| ARTICLE 18 MISCELLANEOUS..... | 53 |
| 18.1 Prevailing Wage..... | 53 |
| 18.2 Employment Discrimination..... | 54 |
| 18.3 Patents..... | 55 |
| 18.4 The Contractor’s Compliance With Law..... | 55 |
| 18.5 Environmental Protection – The Contractor’s Duty To Comply With Applicable Law..... | 56 |
| 18.6 No Personal Liability Of College Officials..... | 56 |
| 18.7 Recovery Of Monies By The College From Other Contracts With The Contractor..... | 56 |
| 18.8 Buy American Requirement..... | 56 |
| 18.9 Compliance With Grant Requirements..... | 57 |
| 18.10 Modification Of Contract..... | 57 |
| 18.11 State Sales Tax Exemption..... | 57 |
| 18.12 Successors and Assigns..... | 57 |
| 18.13 Construction Liens..... | 57 |
| 18.14 Independent Contractor Status..... | 58 |
| 18.15 Third Party Beneficiary Rights Not Intended..... | 58 |
| 18.16 Gifts To College Employees And Agents Prohibited..... | 58 |
| 18.17 Compliance With Procurement Statutes..... | 58 |
| 18.18 Conflict Of Interest..... | 59 |
| 18.19 Confidential Information..... | 60 |
| 18.20 Publicity..... | 60 |

ARTICLE 1
**CONTRACT DOCUMENTS, INTERPRETATION, INFORMATION FOR BIDDERS,
CLAIMS BASED ON BID AND CONTRACT DOCUMENTS**

1.1 Definitions.

Terms defined in the Contract for Construction shall have the meaning provided therein. Definitions for the purpose of these General Conditions include the following:

Addendum: A document issued to bidders by the College prior to the bid due date which supplements, revises or modifies the bid solicitation documents furnished for bidding purposes, and which must be identified and included in bids for the Contract.

Architect: The Architect (A/E) engaged by the College to design the Project, to prepare the design documents and assist with bid documents, and may administer the Contract and act as the agent of the College as described in the Contract.

Bulletin: A document prepared by the Architect describing proposed changes or additions to the Work in the Contract Documents that is issued after Contract award. If the College decides to implement the change, it will provide the bulletin to the Contractor and ask it to submit a change order proposal or request (in accordance with the change order provisions in the Contract for Construction, these General Conditions and other sections of the bidding documents).

Change Order Proposal or Change Order Request: A written proposal or request submitted by the Contractor in accordance with the change order provision of the Contract for Construction, these General Conditions and other sections of the bidding documents, including proposals submitted in response to Contract Change Directives, which proposes cost, time and other terms under which the Contractor will perform changed work under the Contract. If accepted by the College, a written change order signed by the Vice President for Administration and a TCNJ Purchase Order signed by the Contracting Officer of the College, and if accepted by the Contractor in writing, it will become part of the Contract as a change order.

The College's Representative: The College's Representative is a person or persons designated by the College to act on its behalf in administering the Contract for the College. The College's Representative may include the Director of Campus Construction, the Project Manager or an independent construction manager working for the Office of Campus Construction.

College Site Superintendent: The College Site Superintendent is a person or persons designated by the College to witness, observe, record and report on activities in and around the construction site. The Site Superintendent does not have the authority to stop or change the scope of the Work of the Contract Documents.

Contract: The Contract Documents all form the Contract. The Contract represents the entire and integrated agreement between the parties hereto and supersedes prior negotiations, representations or agreements, either written or oral. The Contract may be amended or modified only by a Modification. The Contract Documents shall not be construed to create a contractual

relationship of any kind (1) between the Contractor and the Architect or the Architect's consultants, (2) between the College and a Subcontractor or a Sub-subcontractor, (3) between the College and the Architect or the Architect's consultants or (4) between any persons or entities other than the College and the Contractor. The Architect shall, however, be entitled to performance and enforcement of obligations under the Contract intended to facilitate performance of the Architect's Contractor's duties.

Contract Amendment: The Contract can only be amended by (1) a written amendment identified as such that is signed by the College and the Contractor, (2) a change order signed in accordance with the Contract Documents, (3) a written Contract Change Directive (CCD) issued by the College that should result in a change order unless issued to address some fault of the Contractor, (4) a written approval or acceptance by the College or the Architect of a change requested by the Contractor in writing, provided the request for a change is specifically identified in a submittal.

Contract Change Directive (CCD): A Contract Change Directive (CCD) is a written directive issued by the College which orders an addition, deletion, clarification of a disputed item or revision in the Work, or a response to an emergency. A CCD does not by itself change the Contract, but it should result in a change order which does change the Contract Price or Contract Times if warranted. A CCD should specify the terms of the change order (if deemed warranted by the College) which will result, and/or specify a deadline for the submission by the Contractor of a proper change order request, and/or contain other similar terms.

Contract Documents: The Contract Documents are enumerated in Article 2 of the Contract for Construction.

Contract Limit Lines: The lines shown on the Plans that limit the boundaries of the Project site, and beyond which no construction work or activities shall be performed by the Contractor unless otherwise specified in the Contract Documents, including the Plans and Specifications and supplemental General Conditions.

Contracting Officer: The Associate Treasurer of the College shall be the Contracting Officer in connection with the Contract and the Project. The Contracting Officer and other designee shall have authority to act on behalf of the College under the Contract.

Field Order (FO): A written order issued by the Architect or the College which requires minor changes in the Work that do not result in a change in the Contract Price or the Contract Times. If the Contractor believes that a field order warrants the issuance of a change order that changes the Contract Times or Contract Price, it must notify the College and the Architect in writing within 48 hours, and its notice must specify the terms of the change order that it believes are warranted, including specific time and price change requests.

Plans: The Plans are the graphic and pictorial portions of the Contract Documents showing the design, location and dimensions of the Work, generally including plans, elevations, sections, details, and diagrams.

Project: The Project is the total construction of the Work performed under the Contract Documents and may include construction by the College and by separate contractors that the College has specifically identified.

Specifications: The Specifications are that portion of the Contract Documents consisting of the written requirements for materials, equipment, systems, standards and workmanship for the Work, and performance of related services prepared by the Architect or the College.

Supplemental General Conditions: The part of the Contract Documents which amends or supplements these General Conditions for the Project.

Work: The construction and services required by the Contract Documents, whether completed or partially completed, and includes all other labor, materials, equipment and services provided or to be provided by the Contractor to fulfill the Contractor's obligations. The Work may constitute the whole or a part of the Project.

1.2 Intent Of Contract Documents.

The intent of the Contract Documents is to describe a functionally complete and aesthetically acceptable Project to be constructed and completed by the Contractor in every detail in accordance with the Contract Documents. Any Work, services, materials, equipment or documentation that may be reasonably inferred from the Contract Documents or from prevailing custom or trade usage as being required to produce a complete Project shall be supplied by the Contractor whether or not specifically identified at no additional cost to the College. Where the Contract Documents describe portions of the Work in general terms but not in complete detail, only the best construction practices and only materials and workmanship of the first quality are to be used. Only where the Contract Documents specifically describe a portion of the Project as being performed by others is the Work to be considered to include less than the entire Project.

1.3 Interpretation Of Contract Documents.

When two or more interpretations of a Specification for the Work are possible, the most stringent or the highest cost interpretation shall apply as determined by the Architect. The Architect (or in the absence of the Architect, the College) shall be the sole interpreter of the Plans and Specifications and the Contractor's performance therewith. It is the intent of these Plans and Specifications to provide materials of a quality consistent with the highest standards provided under similar circumstances in the same general geographical area and that will result in long-term use and efficient operation.

1.4 Law And Referenced Standards.

The Contractor is required to comply with all federal, state and local laws and regulations that apply to the Project, the Work and the Contract. Where the Contract Documents refer to any publication, including but not limited to any standard, which affects any portion of the Work or the Project, it shall be considered to mean the edition or revision in effect on the bid due date unless otherwise specified in the Contract Documents. No provision in any publication including

any standard shall create an obligation on the part of the College or the Architect to supervise or direct the Contractor's Work.

1.5 Plans And Specifications.

The Plans will include general plans and such details as deemed necessary to give a comprehensive representation of the construction required. The Contractor shall keep one set of Plans available at the Project site, which shall be available for inspection by the College and the Architect at all times. All alterations affecting the requirements in the Plans must be authorized by the College and the Architect in writing, and shall be promptly noted on the Contractor's record set of Plans, which are maintained at the site for inspection by the Contractor, the College and the Architect.

1.6 Order Of Precedence Of Contract Documents.

Each of the Contract Documents is an essential part of the Contract, and a requirement specified in one part of the documents is binding as if specified in all. The Contract Documents are intended to be complementary and to describe and provide for a complete Project. The obligations of the Contractor under the various Contract Documents shall be cumulative and to the extent that one of the Contract Documents imposes a stricter or more costly requirement or higher standard upon the Contractor than does another Contract Document, the more stringent or more costly requirement or higher standard, as determined by the Architect, shall apply. Otherwise, if there is any conflict among the Contract Documents, the signed Contract for Construction and all approved change orders shall control. As to the other Contract Documents, the order of precedence shall be as follows:

- (a) Contract for Construction
- (b) Addenda
- (c) Supplemental General Conditions
- (d) General Conditions
- (e) Specifications
- (f) Plans
 - i. Notes
 - ii. Large Scale Details
 - iii. Sections
 - iv. Elevations
- (g) Scope of Work Description

1.7 Organization Of Plans And Specifications.

The arrangement of the Plans and the organization of the Specifications into divisions, sections or articles shall not be construed by the Contractor as being intended to divide or allocate the Work among Subcontractors or trades or to establish the scope of the Work to be performed by particular Subcontractors or trades. The College is not liable for the Contractor dividing and separating the Contract Documents into individual packages to Subcontractors. Items that the Contractor fails to include or provide for shall be at the Contractor's sole risk and

cost. The Contract Documents work together as a whole and, therefore, the Contractor is required to coordinate the entire package with all its Subcontractors.

1.8 Required Approvals.

In all cases where approvals or decisions under the Contract Documents are required from the College, the Work shall not proceed without the required approvals and decisions in writing.

1.9 Conformity Of Work To Contract Documents.

All Work performed shall conform to the lines, grades, cross-sections, dimensions, material requirements, tolerances, details and other information in the Contract Documents. The purpose of tolerances is to accommodate occasional minor variations from the middle portion of the tolerance range that are unavoidable despite reasonable construction practices. When a maximum or minimum tolerance value is specified, the material and the Work shall be controlled so that they shall not be preponderantly of borderline quality or dimension.

1.10 Work Involving Existing Structures.

On projects involving alterations, remodeling, repairs, installations or other work in pre-existing structures or systems, the Contractor shall by personal inspection of the existing structures and systems satisfy itself as to the accuracy of any information provided that may affect the quantity, size and/or quality of materials required for a satisfactorily completed Project, including information that is not identified or included in the Plans and Specifications. The Contractor shall provide all material and labor required to complete the Work based on conditions that can be reasonably observed by a competent and diligent contractor before bidding.

1.11 Verification Of Dimensions.

The Contractor shall verify all dimensions at the job site and shall take any and all measurements necessary to verify the information in the Plans. The Contractor shall properly and accurately layout and survey the Work. Any errors or discrepancies affecting the layout of the Work shall be reported to the Architect and the College immediately in writing. No Work affected by any error or discrepancy shall proceed until such discrepancy is resolved by a written decision of the Architect with the consent of the College.

1.12 Manufacturer Literature.

Manufactured articles, materials and equipment shall be installed, applied, connected, erected, used, cleaned and conditioned in accordance with the manufacturer's written instructions unless otherwise specified in the Contract Documents. If there is any conflict between manufacturer literature and the Contract Documents, it shall be reported by the Contractor to the Architect and the College in writing, and the Contractor shall not proceed without a written decision by the Architect with the consent of the College.

1.13 Quality -- General Requirement.

Where no explicit quality or standard are specified for Work, materials or equipment, they shall be new, of good quality, free of defects, suitable for their intended use, in conformity with the Contract Documents, and consistent with the highest quality of the surrounding Work and of the construction of the Project generally.

1.14 Examination Of Contract Documents Before Bidding/Errors.

The Contractor represents and warrants that before bidding it examined and carefully studied the Contract Documents and other documents included or referred to in the bid documents. The Contractor also represents and warrants that the documents are sufficient for bidding and performing the Work at the Contract Price. Should it appear that any of the Work or materials are not sufficiently or properly detailed or explained in the Contract Documents, the Contractor shall notify the College in writing before the bid deadline for submitting questions.

Errors, omissions, conflicts, discrepancies, inconsistencies or other defects in the Contract Documents or between the Contract Documents and any codes, standards or other applicable documents which are capable of being discovered by a diligent and competent contractor before bidding shall be reported to the College in writing before the bid deadline for submitting questions. If errors, omissions, inconsistencies or other defects in the Contract Documents are not discovered until after the bid due date, the Contractor shall promptly notify the College and the Architect of them in writing, provide written recommendations regarding changes or corrections to resolve any such errors, omissions, inconsistencies or defects, and obtain the Architect's written interpretation and approval with the consent of the College before proceeding with the Work affected.

1.15 Site Information.

Soil borings, test pits or other subsurface or site information regarding the physical site and subsurface conditions on or near the site may have been obtained from independent contractors for the purpose of preparing the design documents for the Project rather than for the purpose of contractor estimating or bidding. Such information may be identified or included in the Contract Documents so that it can be reviewed by bidders during the bidding phase, but because of the limited nature and purpose of the information, it shall not be considered to be part of the Contract Documents, and the Contractor must assume responsibility for interpreting and relying upon the information.

1.16 Sufficiency Of Documents Provided For Bidding.

The Contractor represents and warrants that before bidding it carefully studied all reports, surveys and documents included or identified in the bid documents regarding observations, inspections, investigations and tests of the site and subsurface conditions at or near the site, and all information provided to bidders regarding physical conditions at or near the site, including surface and subsurface composition, water, structures and utilities, and that it determined that no further examinations, investigations, tests, studies or data were necessary for bidding or the performance of the Work at the Contract Price. If the Contractor concluded that additional

information is required, it must notify the College in writing before the bid deadline for submitting questions.

1.17 Examination Of Site Before Bidding.

The Contractor represents and warrants that before bidding it visited the site and familiarized itself with and was satisfied as to the general, local and site conditions which may affect the cost, progress and performance of the Work and the Contract, and that its bid and bid price take into account all such conditions. No additional costs will be borne by the College for conditions that existed and were reasonably observable or described at the time of bidding.

1.18 Hazardous Materials On Site.

The Contractor will not be responsible for hazardous environmental conditions uncovered or discovered on the site that were not disclosed in the Contract Documents and that were not caused by the Contractor or anyone working through or under the Contractor. If such conditions are discovered, the Contractor shall stop work and notify the College in writing immediately. The College may issue a written directive to the Contractor requiring it to stop work until the hazardous environmental condition is remedied, and the Contractor will be entitled to an extension of the Contract Times if an extension is warranted under the provisions of the Contract for Construction and these General Conditions regarding extensions. The College may also make changes in the Contract in response to the conditions, and the Contract will be changed in accordance with the change order provisions in the Contract for Construction and these General Conditions.

1.19 Limitation On Claims Based On Contract Documents And Information Provided For Bidding.

The Contractor may not assert claims for extra compensation beyond the bid and Contract Price for constructing the completed Project by reason of any errors, omissions, inconsistencies, or defects in the Contract Documents that are discoverable by a diligent and competent contractor, because of (i) its obligation to review and study the bid documents before submitting its bid, (ii) its representation in the Contract Documents that it did so, and (iii) its obligation to notify the College in writing of any such errors, omissions, inconsistencies, or defects before submitting its bid,. In addition, the Contractor may not assert claims for extra compensation beyond the bid and Contract Price for constructing the completed Project by reason of any lack of information affecting the construction of the Project at the time of bidding, or errors in the information included or referenced in the bid documents except to the extent explicitly permitted by the Contract for Construction or these General Conditions. The Contractor shall notify the College in writing before submitting its bid of any errors or omissions in the information provided or be precluded from seeking extra compensation or asserting a claim. This limitation on claims may be modified and further restricted in the signed Contract for Construction when the Contract Documents explicitly require the Contractor to participate in any aspect of the design phase.

The Contractor may assert claims for extensions and additional compensation in accordance with the provisions of the Contract for Construction and these General Conditions if

information regarding the site that is identified in the bid or Contract Documents is factually inaccurate, and the inaccuracy is one that a reasonably competent and diligent contractor would not discover in preparing a bid. The Contractor may not assert a claim for an extension or extra compensation when it claims, not that the information is factually inaccurate, but rather that conclusions, inferences or judgments made in reliance on accurate information prove to be incorrect.

ARTICLE 2 **THE COLLEGE**

2.1 General Rights And Responsibilities Of The College.

The College as the owner of the Project is entitled to have the Contractor perform and complete the Work in accordance with the Contract Documents, including the time of completion, quality and documentation requirements of the Contract. The College for its part undertakes to furnish the site, to notify the Contractor of any restrictions on the site that could affect the Contractor's performance of the Contract, to obtain approvals relating to the site that are needed for the construction to proceed, to pay the Contractor in accordance with the Contract, and to act reasonably in reviewing all documentation, claims and questions properly submitted to it under the Contract. The College also undertakes to provide the information and items that it expressly agrees in the Contract Documents to provide.

The College shall also have such other rights and responsibilities as are specified in the Contract Documents. The College will not supervise the Contractor's Work or be responsible for the Contractor's construction means and methods, or the Contractor's safety practices, or any failure of the Contractor to comply with the Contract Documents or any laws or regulations.

2.2 The College's Representative, Authority To Decide Contract Questions.

The Contracting Officer delegates its authority to the College's Representative who is authorized to act and make decisions on behalf of the College regarding matters specified in the Contract Documents. However, the College's Representative is not authorized to make or agree to material changes to the Contract Documents or changes involving the Contract Times or Contract Price.

All changes to the Contract Documents including change orders that modify Contract Price, Contract Times or other material change to the Contract Documents must be reviewed and approved by the Contracting Officer or his/her designee. The Contracting Officer designates that the Vice President for Administration is authorized to approve change orders.

The College's Representative, in consultation with the Architect, is authorized to decide on behalf of the College, all questions regarding the quality, acceptability and rate of progress of the Work, all questions regarding the interpretation of the Contract Documents, the acceptability of the performance of the Contract by the Contractor, and the compensation due to the Contractor. Where the College's Representative is authorized to render decisions under the

Contract for Construction or these General Conditions regarding disputes or claims, he/she shall consult with the Architect and shall not act arbitrarily so as to unfairly benefit either the College or the Contractor.

2.3 Required Approvals.

In all cases where approvals or decisions are required from the College under the Contract Documents, such approvals or decisions shall be made reasonably, except in cases where a specific standard applies such as, for example, situations where the College is entitled to exercise unqualified discretion in selecting the types of materials, products or construction which it decides to procure.

2.4 Information Required From The College.

Information which the Contract Documents specify the College will provide shall be provided with reasonable promptness.

2.5 Permits.

The College will arrange and pay for permits and permit inspections, including building code permits except to the extent that the Specifications specify otherwise. The Contractor will arrange for and coordinate all inspections and the dates and times for all inspections with local, state and independent agencies and include the College's Representative or the Site Superintendent.

2.6 The College's Inspection Of The Project.

The College shall have the right to be represented at the site by the College's Representative(s), the Site Superintendent and other College employees designated by the College, the Architect, and other consultants designated by the College or the Architect. The College and its representatives shall have the right to visit the site, inspect Work and materials, inspect Project documentation, conduct tests, attend meetings, meet with the Contractor' and the Subcontractors' representatives, investigate problems, conduct studies, and make reports. The College and its representatives shall be allowed access to all parts of the Work, and the Contractor shall furnish them with information and assistance when they request it.

The Contractor shall give the College and the Architect timely notice of readiness of Work for observation, inspection and testing, and shall cooperate with these efforts. The Contractor shall also comply with any inspection and testing procedures specified in the Contract Documents.

The Contracting Officer, the Architect and the College's Representative shall have the right to direct the Contractor to remove or uncover unfinished Work if deemed necessary to inspect Work or materials in place.

If Work is covered before it is inspected because the College, the Architect or any consultant were not afforded reasonable notice and an opportunity to inspect, or where the

Contract Documents or any law require an inspection, the Contractor shall uncover and replace Work at its own expense if required to do so by the College.

If any other portion of the Work not specifically required to be inspected is covered, and the College or the Architect did not ask to observe or inspect the Work before it was covered, the College may nonetheless ask to inspect the Work. If the College makes such a request, the Contractor shall uncover the Work for inspection. If the Work uncovered is found to be in accordance with the Contract Documents, the cost of uncovering and replacement shall be paid by the College by a change order. If the Work uncovered is found not to be in compliance with the Contract Documents, the Contractor shall pay all costs of uncovering and replacement, and also remedy the defect or deficiency at its own cost.

The College at all times retains the right to stop all or part of the Work by a written direction because of defective Work until the defect is eliminated. This right shall not give rise to any duty on the part of the College to exercise the right for the benefit of the Contractor or those performing its Contract.

The College at all times retains the right to stop all or part of the Work due to concerns with the effectiveness of the Contractor's safety program required under Article 5.2. The College may require the Contractor to provide a written plan to correct safety deficiencies, an on-site safety supervisor, or other administrative or engineering controls to ensure the safety of personnel impacted or potentially impacted by Contractor operations. The Contractor shall indemnify, defend and hold the College harmless from fines issued by Federal, State or Local OSHA enforcement.

2.7 The College's Inspectors, Duties And Limitations

If the College designates inspectors to inspect Work and materials and Project documentation, they will not be authorized to alter or waive any requirements or provisions in the Contract Documents. The College's inspectors will not be authorized to issue instructions contrary to the Contract Documents or to act as foremen or employees of the Contractor. The College's inspectors have the authority to reject unsuitable Work or materials, subject to written confirmation by the College's Representative. If the Contractor believes that any action of a College inspector is contrary to the Contract Documents, it shall notify the College's Representative and the Architect in writing within 48 hours. The College does not undertake to have inspectors sufficient in number to inspect every item of Work or material as it is provided, or to have inspectors with the expertise needed to judge every aspect of the Work.

The Contractor shall remain responsible for defective Work or materials irrespective of any inspections or lack of inspections during the Work. If the Contractor seeks a binding determination of the acceptability of Work or materials during the performance of the Contract, it shall do so by making a written request for such a determination to the College's Representative with a copy to the Architect.

2.8 The College's Rejection Of Defective Work.

The College shall have the right to reject defective Work, materials, or equipment at any time, and to require the Contractor to remove and replace it at the Contractor's expense. The Contractor shall also be responsible for repairing damage to other work caused by defects or deficiencies in its Work. The College's Representative, upon consultation with the Architect, may elect to accept Work or materials that do not conform to the Contract Documents and to credit or reduce the Contract Price, but the College shall have no contractual obligation to elect this remedy. Changes to the Contract Documents in these circumstances shall be recorded as a change order under the change order provision of the Contract for Construction and these General Conditions.

ARTICLE 3 **THE ARCHITECT**

3.1 The Architect's General Role.

The Architect is, by contract with the College, responsible for the design of the Project. During construction, the Architect is responsible for reviewing the Contractor's submittals to determine if they conform to the Contract Documents and good industry practice, to provide some level of inspection to determine if Work and materials provided by the Contractor conform to the Contract Documents and good industry practice, and to review the Contractor's payment applications. During the performance of the Work, the Architect may investigate any defects and deficiencies in the Work or materials provided and make recommendations to the College regarding the defects or deficiencies. The Architect will conduct inspections to determine if the Contractor has achieved proper Substantial and Final Completion and submitted all documents required at Substantial and Final Completion. The Contractor shall cooperate with and render assistance to the Architect in the performance of these duties.

3.2 The Architect's Access And Facilities.

The Contractor shall allow the Architect and its consultants access to the Project at all times and shall facilitate their access to inspect Work and materials and Project documentation. The Architect and its consultants shall be permitted to attend job meetings, scheduling meetings and other meetings at the site and the Contractor shall facilitate their ability to do so. The Contractor shall provide an office at the site for the Architect if the Specifications require it to do so.

3.3 Limitation Of The Architect's Responsibilities.

The Architect will not be responsible for or have control of construction means and methods or safety precautions and programs in connection with the Work. The Architect will not be responsible for or have control of acts or omissions of the Contractor, its Subcontractors, or any of their agents or employees, or any other person performing any of the Contract Work.

3.4 The Architect's Rejection Of Work.

The Architect may recommend rejection of Work or materials that it believes does not conform to the Contract Documents. Whenever the Architect considers it necessary or advisable, it may recommend to the College special inspections or testing of Work or materials, including completed Work and materials.

3.5 The Architect's Review Of The Contractor's Submittals.

The Architect will review, approve or take other appropriate action regarding the Contractor's submittals, such as shop drawings, product data and samples, to assure that they conform with the design requirements and Contract Documents. The approval of a specific item shall not be deemed to constitute approval of an assembly of which the item is a component.

3.6 The Architect's Review Of The Contractor's As-Built Plans.

The Architect will periodically review the Contractor's as-built plans maintained at the site to ensure that they are up-to-date, and shall review the completed as-built plans at Project completion to ensure that they are complete and are provided to the College.

3.7 The Architect's Determination Of Substantial and Final Completion.

The Architect will conduct inspections to determine the dates of Substantial and Final Completion and to determine if the Contractor has properly Substantially and Finally completed the Project. The Architect will obtain from the Contractor all written warranties and all other documents that the Contractor is required to provide at Substantial and Final Completion of the Project.

ARTICLE 4 **THE CONTRACTOR**

4.1 The Contractor's Responsibility For Performance Of The Contract And Work.

The Contractor is the person or entity identified as such in the Contract. The Contractor shall be lawfully licensed in the jurisdiction where the Project is located.

The Contractor shall perform all of the duties in the Contract Documents, shall furnish the labor, materials and equipment to complete the construction of the Project in accordance with the Contract Documents, and furnish all services, labor, materials and equipment necessary or appropriate to construct the Project. The Contractor shall manage, supervise, schedule, direct, and inspect the Work as competently, skillfully, and efficiently as possible, and shall be solely responsible for all construction means, methods, techniques, safety, security, sequences, procedures, and coordination.

The Contractor shall comply with all applicable laws, and shall establish and maintain reasonable quality assurance and safety programs in connection with its Work. The Contractor shall complete the Work in compliance with the Contract Documents and by Milestone, Substantial Completion and Final Completion Dates in the Contract for Construction or any authorized extensions thereof. The Contractor shall maintain good order and discipline at the site at all times.

4.2 The Contractor's Key Personnel.

The Contractor shall assign to the Project a Project executive, Project manager, superintendent, and scheduler, and such other key personnel as are specified in the Contract for Construction or as required to carry out the requirements of the Project. The Contractor shall not remove or replace such key personnel without the College's written approval. The College has the authority to reject and have replaced any staff member of the Contractor or any of the Subcontractors for any non-discriminatory reason.

4.3 The Contractor's Supervision Of Contract Work/The Superintendent.

The Contractor shall supervise and be responsible for the acts and omissions of the Contractor's employees, agents, Subcontractors, sub-subcontractors, suppliers and other persons performing portions of the Work and the Contract. The Contractor's designated Project superintendent shall be at the Project site at all times when Work is in progress. The Contractor may designate in writing an alternate superintendent who must be approved in writing by the College. The superintendent (or alternate) shall have full authority to represent and act for the Contractor at the site and shall have full authority to execute orders and directives of the College without delay.

Communications from the College or the Architect to the superintendent shall be deemed to have been given to the Contractor. The superintendent shall be capable of and authorized to respond to all hazardous and unsafe conditions at the Project site and to implement prompt corrective measures to eliminate all unsanitary, hazardous or dangerous conditions at the site. The College may suspend all or part of the Work at the Project site if the superintendent (or alternate) is not present at the Project site. Such a suspension shall not be the basis of a claim against the College, including without limitation any claim for additional time or extra cost.

The superintendent shall attend all meetings at the Project site including job meetings, scheduling meetings, and meetings with the College and/or the Architect. The superintendent shall have a written plan that must be approved in writing by the College for responding to emergencies when the Work is not in progress. The Contractor shall also utilize qualified competent craftsmen on the Project.

4.4 Cooperation With The College And Other Contractors.

The College reserves the right to contract for and perform other or additional work on or adjacent to the Project site. When separate contracts are let within the limits of the Project site, or in areas adjacent to the site, the Contractor shall perform its Work so as not to interfere with or

hinder the progress or completion of the work being performed by other contractors. The Contractor shall also affirmatively cooperate with such other contractors and coordinate its activities with theirs, and include coordination measures in the Project Schedule. The Contractor shall arrange its Work and shall place and dispose of materials being used so as not to interfere with the operation of other contractors within the limits of the Project site. The Contractor shall join its Work with that of the other contractors in an acceptable manner and shall perform its Work in proper sequence with that of other contractors.

If there is a disagreement as to the respective rights of the Contractor and others doing work within the limits of or adjacent to the Project site, the College shall determine the respective rights of the contractors involved to secure the satisfactory completion of all affected work. The Contractor shall not be entitled to additional compensation beyond its Contract Price that may arise because of inconvenience, delay, or loss experienced by it as a result of the presence and operations of other contractors working within the limits of or adjacent to the Project site.

The College reserves the right to occupy any portion of the Project that is ready for occupancy prior to Final Completion and acceptance of the Project, after Local and State Construction Enforcing Agency approval.

The occupancy of any portion of the Project does not constitute an acceptance of any Work nor does it waive the College's right to liquidated damages or constitute an acceptance of any Work, as the Project will be accepted as a whole and not in units. Prior to such occupancy, however, the Architect, a representative of the College, and the Contractor shall fully inspect the portions of the Project to be occupied, preparing a complete list of omissions of materials, faulty workmanship, or any items to be repaired, torn out or replaced. The College will assume responsibility for damage to premises so occupied of any items not on this list when such damage is due to greater than normal wear and tear, but does not assume responsibility for improper or defective workmanship or materials.

4.5 Performance Of The College Directives.

When the College issues a written directive to the Contractor under the authority of any provision in the Contract for Construction or these General Conditions, the Contractor shall perform as directed in a diligent manner and without delay. Compliance with written directives shall not adversely affect the rights of the Contractor under the Contract for Construction, these General Conditions or law, but if the Contractor objects to a directive of the College, or claims that a directive infringes upon its rights or entitles it to a change order, it shall notify the College in writing within 2 business days of any directive and describe any objection it has to the directive and the reasons for its objection. Objection to a written directive does not relieve the Contractor of the obligation to comply with the directive and proceed in a diligent manner to implement the directive without delay.

ARTICLE 5
PERFORMANCE OF WORK

5.1 Protection Of Work/Materials.

The Contractor, shall at its own expense, protect all finished Work and materials from damage and keep them protected until the Project is accepted as Substantially Completed, and shall repair or replace any Work or material damaged before acceptance. After the Project is accepted as Substantially Complete, the Contractor will remain responsible up through Final Completion for damage to Work and materials caused by it or its Subcontractors or others participating in the performance of its obligations under the Contract Documents. The Contractor shall also secure and protect its own tools, equipment, materials and supplies, and the College shall have no liability for damage, theft or injury to the Contractor's property.

5.2 Safety And Safety Programs.

The Contractor shall have full responsibility for safety at the Project site at all times up to Final Completion and acceptance of the Project and the Contract. The Contractor shall provide for the safety of all individuals on the Project site, and take measures to ensure that individuals on or near the Project site are not injured by the performance of the Contract. The Contractor shall establish and maintain a Project safety program in accordance with all applicable laws including OSHA, good industry practice, and any additional requirements in the Contract Documents. If the College or the Architect become aware of an unsafe situation, the Contractor will immediately respond to remedy the safety concern and shall take all other actions necessary to comply with Article 2.6.

5.3 Emergencies Affecting Safety.

If there is an emergency affecting the safety of persons or property, the Contractor shall take immediate action to prevent damage, injury or loss. The Contractor shall notify the College in writing of the situation and all actions being taken immediately or as soon as possible. If, in the opinion of the Contractor, immediate action is not required, the Contractor shall notify the College in writing of the emergency situation and proceed in accordance with the College's instructions. However, if loss, damage, injury or death occurs that could have been prevented by the Contractor's prompt and immediate action, the Contractor shall be liable for all costs, damages, claims, actions, suits, attorney's fees and other expenses that result.

Any additional compensation or extension of time claims by the Contractor on account of emergency Work shall be determined in accordance with the change provisions of the Contract for Construction and these General Conditions. The Contractor shall be responsible for emergencies and costs and delays resulting therefrom that could have been foreseen or prevented with normal diligence, planning, and supervision of the Work, or that are caused by the Contractor's failure to properly perform the Contract.

The Contractor shall provide the College with a list of the names and telephone numbers of its employees and employees of each Subcontractor designated to be contacted in case of an emergency during non-working hours. A copy of this list shall be displayed prominently at the

Project site so that it is visible when the Project site is secured and shall be provided to the College's campus police department.

5.4 Working Hours.

Except as required for the safety or protection of persons or property, or as specified in the Contract Documents, all Work at the site shall be performed during regular working hours, and not on Saturdays, Sundays, legal holidays, the College's commencement days, resident move-in and move-out days or other days specifically noted in the Contract Documents without the prior written consent of the College, which will not be unreasonably withheld.

5.5 Site Security.

The Contractor shall provide, maintain and oversee security at the site if required in the Specifications. The Project site shall be fenced as specified in the Specifications, and the Contractor shall control access when gates are unlocked or open. The fence shall provide a physical barrier to the site and protection from visible nuisance. At a minimum, the fence shall be firmly secured with buried posts or weighted feet, top rails, metal fabric, and locking gates. Contractor shall immediately notify the College in the event of unauthorized entry to the site.

5.6 Site Use.

The Contractor shall confine construction equipment, storage and Work to the Project site absent written approval from the College. Any request by the Contractor to use areas outside the Project site must be described in written form and included with the Contractor's bid.

5.7 Building Access.

The Contractor shall be responsible for the sign out, distribution, safe use and return of all building keys and/or access cards, and shall be responsible for all costs associated with failure to return these items (e.g., the cost to re-key/re-implement the system).

5.8 Minimize Interruption.

The Contractor acknowledges that the College is an existing educational facility and that classes may be in session during construction. The Contractor agrees to conduct its Work with as little disruption as reasonably possible to the College's students, faculty, employees and guests, and will maintain a safe environment for the College's students, faculty, employees and guests, in addition to the Contractor's employees and workers of all tiers. The Contractor and its Subcontractors and employees of all tiers must display courtesy and consideration with and shall refrain from discriminating against or harassing the College's students, faculty, employees, visitors and guests at all times. The Contractor will not allow smoking, vaping, alcohol, drugs, any firearms, or other weapons on the College's property at any time. The Contractor shall abide by all campus traffic regulations.

5.9 Submittals (Shop Drawings, Product Data, Samples).

Prior to the beginning of Work on the Project, the Contractor shall furnish to the Architect and the College for their review and approval, a schedule setting forth all the submittals, including shop drawings, product data and samples required by the Contract Documents, that the Contractor intends to submit to the Architect for review and approval, the date upon which the Contractor shall make each such submittal and the date upon which the Architect shall complete its review of each such submittal, which in no event shall be less than ten (10) days from receipt (“Submittal Schedule”). The Architect and the College shall identify all submittals that will require more than ten (10) days to review and notify the Contractor of the required review period. The Contractor shall adjust the Submittal Schedule to accommodate the extended review period. The Architect shall endeavor to conduct its review and approval of all submittals in accordance with the Submittal Schedule. In the event that a submittal is made that is not set forth on the Submittal Schedule, the Architect shall review and return such submittal within ten (10) working days from receipt.

Submittals shall be complete as to quantities, details, dimensions and design criteria. The Architect will approve and the College will review submittals if they conform to the Contract Documents, the design concept and good industry practice. The Contractor shall note its approval of all submittals and the date for any submittals prepared by any Subcontractor or supplier, and it shall be responsible for determining and verifying all materials, field dimensions, field construction criteria, and coordination requirements pertaining to the submittal.

The Contractor will not be relieved of responsibility of deviations in submittals from the requirements in the Contract Documents by reason of approvals of the submittals unless the Contractor specifically identifies the deviation in the submittal and the Architect and the College expressly approve the deviation in writing. The Contractor shall be responsible for errors or omission in its submittals. No Work or materials included in a submittal shall begin until the submittal is approved by the Architect and the College.

5.10 Layout And Dimensional Control.

The Contractor shall be responsible for locating and laying out the Project components and all of the Project parts on the Project site in strict accordance with the Plans, and shall accurately establish and maintain dimensional control. The Contractor shall employ a competent and licensed New Jersey engineer or land surveyor as appropriate to perform all layout Work and to fix the level and location of excavations, footing base plates, columns, walls, floors and roof lines. The Contractor shall furnish to the College and the Architect certifications that each such level is as required by the Plans as the Work progresses.

The plumb lines of vertical surfaces shall be tested and certified by the Contractor's engineer or surveyor as the Work proceeds. The engineer or surveyor shall establish all points, lines, elevations, grades and bench marks for the proper control and execution of the Work. The engineer or surveyor shall establish a single permanent benchmark to be approved by the Architect, to which all three coordinates of dimensional control can and shall be based. The engineer or surveyor shall verify all topographical and utility survey data, and all points, lines, elevations, grades and benchmarks furnished by the College.

Should any discrepancies be found between information in the Plans and the actual site or field conditions, the Contractor shall notify the Architect and the College in writing, and shall not proceed with any Work affected until it receives written instructions from the College.

The Contractor is required to provide a final “as built” survey from a New Jersey licensed/certified surveyor of the Project site showing all structures, elevations, grades and required information on the Project site and submit to the College in CADD format.

5.11 Construction Access, Roads, Walks, And Parking.

The Contractor shall construct and keep all roadways, drives, walkways and parking areas within or near the site free and clear of debris, gravel, mud or any other site materials, including, for example, the cleaning of muddy wheels and undercarriages on vehicles before they exit the site. The Contractor shall be responsible for any citations, fines, or penalties imposed on it or the College for failing to comply with applicable local rules or laws regarding its use of roads and the like.

The Contractor shall obtain permission in writing from the College before using for construction purposes any existing driveways, parking areas, walkways or areas not specifically designated for such use in the Contract Documents. The Contractor shall maintain such driveways and areas in good and clean condition during construction and not damage them. At Final Completion, the Contractor shall leave them in the same condition as they were at the start of the Work. Conditions of such facilities before use shall be photographed and otherwise documented by the Contractor. The Contractor shall not commence construction of permanent driveways, parking areas or walks on the Project site without the written approval of the College.

Any existing walkways, driveways, aprons, or curbs damaged by the Work of the Contract Documents shall be replaced in kind, at the Contractor’s expense, immediately upon Project completion, or as required to maintain campus safety and campus aesthetics.

5.12 Construction Site Condition, Storage, Dust Control.

The Contractor shall provide reasonable, safe and orderly storage for its equipment, tools and materials, and shall not unreasonably encumber the site. The Contractor shall keep the site and the Project free from the accumulation of refuse, debris and scrap materials caused by its operations so that the site has a neat, orderly and workman-like appearance. Loading, cartage, hauling and dumping will be at the Contractor’s expense. The Contractor shall provide, at its expense, temporary dust-proof partitions around areas of work in existing buildings, and where reasonably required, in new building areas.

5.13 Photographs.

The Contractor shall provide, at its expense, monthly progress photographs of the Project. The photographs shall be 8 inches by 10 inches and shall be submitted to the College in duplicate monthly. Unless otherwise specified in the supplemental general requirements, four photographs

shall be submitted each month which provide views of the Project taken from the same four points each, which points shall be selected by the Architect.

5.14 Project Sign.

The Contractor shall, at its expense, provide, erect and maintain two Project signs at the site, which shall be described in the Contract Documents. The College will specify the location of the signs. The signs shall be painted by a professional sign painter or prepared by a professional graphic artist. No other signage will be permitted at the site. The signs shall include the name and cell phone number of a Contractor-designated project lead that is available for 24-hour contact in case of emergency. The Contractor shall remove the signs when the Project is finally accepted unless the College requests that they be removed earlier.

5.15 Soil Conservation.

The Contractor shall employ reasonable measures to conserve the soil at the site, and determine and comply with all soil conservation measures required by the Mercer County Soil Conservation District.

The Contractor shall coordinate and schedule all soil conservation inspections, shall provide the College with written notice of all such inspections so that the College may attend the inspections if it chooses in its sole discretion to do so, and shall provide the College with all site inspection notes, approvals or notices.

5.16 Temporary Facilities, Services, Electric, Heat And Enclosures.

The Contractor shall provide storage areas, temporary drives and sidewalks, employee parking areas, staging areas, excavation borrow/spoil areas, commercial canteen areas, field offices including a meeting room, telephones, toilet facilities, and other temporary facilities that are necessary to perform the Work or that may be required by the Project Specifications. The Contractor shall locate these facilities on the Project site, and the location shall be subject to the approval of the College.

The Contractor shall provide adequate and clean temporary toilet facilities on the Project site in locations to be approved by the College, and they shall be serviced at least twice a week by a firm qualified and experienced in such functions. The Contractor shall provide such temporary electricity, water, and other utilities that are necessary to perform the Work, or that may be required by the Project Specifications. The Contractor shall also supply such temporary enclosures and heat that are necessary to perform the Work or that may be required by the Project Specifications. The Contractor and the Subcontractors will not enter or use any College facilities not required by the Work of the Contract.

Temporary electric and heat shall be furnished by the Contractor for the benefit of other contractors working on the Project if specified in the Project Specifications.

The Contractor shall not anticipate using the permanent heating or air conditioning system in a building for temporary heat or air conditioning prior to the acceptance of the Project as Substantially Complete unless specified otherwise.

Any natural gas, combustible material, or hazardous material containers utilized by the Contractor must be stored in a safe, ventilated location approved by the College. The Contractor must also submit for approval a reasonable safety plan for the operation of temporary heat equipment. The Contractor shall be solely responsible for any natural gas, combustible material or hazardous materials containers utilized by the Contractor or any of its Subcontractors and shall indemnify, defend and hold harmless the College from any fines, costs, expenses, liabilities, damages, etc. resulting from the Contractor's or any of its Subcontractors' use of such materials.

5.17 Substitutions.

To the extent that the Contractor includes in its bid substitute materials or equipment or construction methods in lieu of those specified in the Contract Documents, it does so at its own risk. Any substitution must be equal in type, function and quality to the item required in the Contract. The Contractor must submit all information required within 20 days of the Contract award to determine if the proposed substitute is equal to the requirements of the Contract Documents, and any substitution must be approved in writing by the Architect and the College.

The College shall have complete discretion to decide whether it will accept any substitution. No substitution shall result in any increase in the Contract Price or Contract Times. The Contractor in its application for the substitution must certify in writing that the substitution is equal to what is specified in the Contract Documents in all material respects and will not increase the Contract Times or Contract Price of the Work.

Should the substitution be rejected, the Contractor will then be required to provide the specified product, material or method at no additional cost to the College and no change in the Project Schedule.

5.18 License Fees.

The Contractor shall be responsible for obtaining the right to use any equipment, design, device or material required to perform the Contract, and shall include in its Contract Price any license fee or royalty required.

ARTICLE 6 **SUBCONTRACTORS**

6.1 The Contractor's Responsibility For Subcontracted Work.

The Contractor shall be fully responsible to the College for the proper performance of the Contract irrespective of whether the Work is performed by the Contractor's own forces or by Subcontractors employed by the Contractor. The Contractor shall be responsible for the acts and

omissions of its Subcontractors and suppliers on the Project and shall take appropriate measures if they are not properly supervising or performing their Work.

6.2 Subcontractor Identification And Approval.

The Contractor shall have included with its bid for the Contract, the names, addresses and license numbers of all Subcontractors that it proposes to utilize on the Project for plumbing and gas fitting work, HVAC work, electrical work, structural steel and ornamental iron work. No Subcontractor may perform Work on the Project until it has been approved in writing by the College.

Within 20 days after issuance of the Notice to Proceed, the Contractor shall furnish to the Architect and the College in writing for review by the Architect and the College a list of the names of all Subcontractors, sub-subcontractors, fabricators, manufacturers, sources of supply, articles, devices, fixtures, pieces of equipment, materials and processes proposed for each item of Work using AIA Document G705-2001, List of Subcontractors. The Architect and the College will notify the Contractor in writing if either the College or the Architect, after due investigation, has reasonable objection to any names on such list.

In submitting the names of Subcontractors, the Contractor shall (1) list the name and address of the Subcontractor, (2) provide the name and address of all sub-subcontractors for each significant subdivision of the trade or work, and (3) reference in the form of a list at least 3 jobs similar in size and quality to the Project performed by the subcontractor in the last 5 years, with name and location of work, dollar value and names of the College and the Architect.

In submitting sources of supply, articles, devices, fixtures, piece of equipment and materials, including those under subcontracts and sub-subcontracts, the Contractor shall list (1) the name and address of the source of supply, and (2) the name of the manufacturer of the items.

If the College disapproves of a proposed Subcontractor, it will provide the reason for its decision in writing. The College will not be liable for any extra cost or delays caused by the reasonable disapproval of proposed Subcontractors. The approval of Subcontractors by the College shall not relieve the Contractor of the responsibility for complying with all of the provisions of the Contract Documents including those performed by the Subcontractors. Subcontractors approved by the College may not be changed without prior notice to and written approval by the College.

Payment to the Contractor shall not be made until the list of Subcontractors (as required above) has been provided to the Architect and College.

6.3 Subcontractor Qualifications.

The College may disapprove of a proposed Subcontractor if (i) it has a reasonable objection to the Subcontractor, (ii) there is evidence of poor performance on other Projects or financial problems, (iii) the Subcontractor has been suspended or debarred by any public agency within the State of New Jersey, (iv) the Subcontractor is not properly licensed and registered to do business in New Jersey or with the New Jersey Department of Labor regarding prevailing

wages, or (v) the Subcontractor has been charged with or convicted of violating any laws, including but not limited to, the New Jersey Prevailing Wage Act, criminal laws, public procurement laws, anti-trust laws, election laws, laws against employment discrimination, environmental laws, tax laws, professional licensing laws, or laws regarding attempts to improperly influence the College or other public officials.

Subcontractors shall utilize qualified, competent craftsmen on the Project.

6.4 Subcontractor Compliance With Contract/Subcontractor Supervisors.

The Contractor shall require its Subcontractors on the Project to comply with all pertinent terms of the Contract Documents, and shall include all appropriate terms and provisions in written subcontracts on the Project to achieve proper Contract performance. Each Subcontractor shall have competent superintendents and foremen supervising their work, and the Contractor shall take appropriate measures if they fail to do so.

6.5 No Contractual Relationship Between The College And Subcontractors.

The Contractor shall enter into written subcontracts with each and every Subcontractor and supplier solely in its own name. No approval by the College of any Subcontractor or supplier and nothing in the Contract Documents shall create any contractual relationship or duties between the Contractor's Subcontractors and the College. Nothing in the Contract Documents shall cause any of the Contractor's Subcontractors or suppliers to be deemed a third-party beneficiary of the Contract between the College and the Contractor, and nothing herein shall give any of the Contractor's Subcontractors or suppliers any rights or claims directly against the College.

6.6 Contingent Assignment of Subcontracts.

Each subcontract agreement for a portion of the Work and any purchase order for materials or equipment may, in the College's sole discretion, be assigned by the Contractor to the College, provided that

- (a) assignment is effective only after termination of the Contract by the College for cause or for convenience and only for those subcontract agreements that the College accepts by notifying the Subcontractor and the Contractor in writing and only on such terms and conditions acceptable to the College;
- (b) assignment is subject to the prior rights of the surety, if any, obligated under bond relating to the Contract;
- (c) if the College elects to take an assignment of any subcontract or purchase order, the Contractor shall execute all papers necessary to effectuate the assignment; and
- (d) the assignment shall not relieve the Contractor of its existing obligations to any Subcontractor or Supplier, nor shall it cause the College to assume

any of the Contractor's obligations to any Subcontractor or Supplier that arose prior to the termination.

When the College accepts the assignment of a subcontract agreement or purchase order, the College assumes the Contractor's rights and obligations under the subcontract going forward. Upon such assignment to the College, the College may further assign the subcontract to a successor contractor or other entity.

ARTICLE 7
TIME, LIQUIDATED DAMAGES, DELAY CLAIMS AGAINST THE COLLEGE.

7.1 Contract Times.

The Contractor shall begin the Work within 10 days after the issuance of a Notice to Proceed by the College, and shall perform the Work in the Contract Documents by the dates specified in the Notice to Proceed, including Construction Start, Milestone, Substantial Completion and Final Completion Dates (collectively, "Contract Times"). As specified in the Contract for Construction, if the Work is to be performed in phases, the College may issue separate Notices to Proceed for each phase, which shall specify the Construction Start, Milestone, Substantial Completion and Final Completion Dates for that phase. The College may, in its sole discretion and at no cost to the College, choose to delay the issuance of a Notice to Proceed and the Construction Start Date for any phase until after the Contractor has achieved Substantial or Final Completion of any other phase.

7.2 Liquidated Damages For Delay.

If the Contractor fails to Substantially Complete any phase of the Work or the entire Work by the Substantial Completion Date(s) set forth in the applicable Notice to Proceed (as extended by Change Order, if applicable), and the delay is not excused by the College, then the Contractor shall pay the College the amounts specified in the Contract for Construction as liquidated damages for delay for each calendar day that the phase of the Work or the entire Work is not Substantially Completed beyond the applicable Substantial Completion Date

**7.3 Delay Claims By The Contractor Against The College --
Limitations.**

The Contractor may not assert claims against the College for extra compensation by reason of any delays in its Work resulting from acts or omissions of any third parties irrespective of extensions granted under the Contract, including but not limited to delays caused by third parties such as the Architect, other contractors, utilities and governmental authorities.

The College shall only be required to pay additional compensation for delays caused by the College itself, and only to the extent required by N.J.S.A. 2A:58B-3 (delayed performance caused by the College's own negligence, bad faith, active interference or other tortious conduct, but not for reasons contemplated by the parties and not for the negligence of others including

others under contract with the College on the theory that such negligence should be imputed to the College). The College shall not be liable for any period of delay when there is a concurrent delay for which the College is not responsible.

When the Contractor is entitled to extra compensation for delay under the Contract for Construction and these General Conditions, it can only assert claims for extra costs at the job site, and may not assert claims for extra costs for home office expenses, home office overhead, lost profit or revenue, or consequential losses as that term is defined by New Jersey law. Any additional compensation under this Article shall also be subject to the provisions in the Contract for Construction and these General Conditions regarding claims, and the provisions in the Contract for Construction and these General Conditions regarding the maintenance and availability of cost records.

ARTICLE 8 **PROJECT SCHEDULE**

8.1 General Project Schedule Requirements.

The Contractor shall schedule the construction Work and determine the most feasible means and order for the Work to complete the Project within the times required by the Contract. The Contractor shall prepare a Project Schedule and monthly schedule updates, which must be approved in writing by the College and the Architect. The Contractor shall perform the Contract and the Work in accordance with the Project Schedule. The Project Schedule should include a schedule of submittals for approval as required herein. The Project Schedule must be submitted before any Work (other than mobilization to site and general layout and site preparatory work) on the Project can begin under the Notice to Proceed. When the Contractor's Project Schedule is approved in writing by the College, it shall become an additional Contract Document and the Contractor shall be required by the Contract to comply with it. The Project Schedule and any updates to it shall be used in determining the amount of the monthly progress payments to the Contractor. The College may also use the Project Schedule and updates to determine if the Contractor is adequately planning and performing the Work in accordance with the Contract Documents.

8.2 Form And Content Of Project Schedule.

The Contractor shall prepare the Project Schedule using Critical Path Method (CPM) scheduling techniques. The Contractor shall utilize the latest revision of Primavera P3 or Microsoft Scheduling software. The Contractor shall prepare a detailed schedule which shows how it will plan, organize, execute and complete the Work. The Project Schedule shall be in the form of an activity oriented network diagram (CPM). The principles and definitions used in this Article shall be as set forth in the Associated General Contractors of America (AGC) publication "Construction Planning and Scheduling", copyright 1994.

The detailed network diagram shall provide sufficient detail and clarity of form and technique so that the Contractor can plan, schedule and control the Work properly, and the College and the Architect can readily monitor and follow the progress of all portions of the

Work. The network diagram shall comply with the limitations imposed by the scope of the Work and contractually specified Milestone, Substantial Completion, and Final Completion Dates. The Project Schedule shall include the arrow or network diagram and the computer produced schedule with dates. The Project Schedule shall include and reflect the following factors:

- (a) Project phasing, contract Milestone, Substantial and Final Completion Dates.
- (b) The structural breakdown of the Project.
- (c) The types of Work to be performed and the labor trades involved.
- (d) Reasonable logic and activity durations.
- (e) Reasonable coordination of all activities.
- (f) Purchase, manufacture and delivery activities for all major materials and equipment.
- (g) Deliveries of equipment furnished by the College.
- (h) Allowances for work by separate contractors identified in writing by the College at the time of Contract award.
- (i) Submittals and approvals of shop drawings, material samples, and other required submittals.
- (j) Subcontract Work.
- (k) Crew flows and sizes (manpower).
- (l) Assignment of responsibility for performing all activities.
- (m) Access and availability to Work areas.
- (n) Identification of interfaces and dependencies with preceding, concurrent and follow-on contractors, and sequences and interdependence of activities.
- (o) Testing and inspections.
- (p) Phased or total inspection, acceptance, and takeover by the College.
- (q) Utilization of the Project Schedule to determine amounts of monthly progress payments.
- (r) Activities required of the College and the Architect such as approvals, including reasonable durations for the activities.

Activities should be set forth in working days and have a maximum duration of 60 days, except for non-construction activities such as the procurement and delivery of materials and equipment. All durations shall be the result of definitive manpower and resource planning by the Contractor. The level of detail in the Project Schedule shall be subject to the approval of the College. The Project Schedule shall include a reasonable approach to achieve Milestone, Substantial Completion and Final Completion Dates in the Contract. Any failure of the Contractor to include any element of the Work in the Project Schedule shall not excuse the Contractor from completing that Work and all of the Work needed to complete the Project by the Milestone, Substantial Completion and Final Completion Dates in the Contract.

The network diagram is to be prepared by a computer plotter. The logic diagram will be pure logic and shall not be drawn to time scale. The logic diagram shall be drawn on 30" x 42" size sheets and prepared on a tracing/mylar or similar material suitable for reproducing high quality prints.

8.3 Computerization Of Project Schedule.

The mathematical analysis of the detailed network diagram shall be made by computer, and the tabulation for each activity shall include the following:

- (a) Activity numbers.
- (b) Activity descriptions.
- (c) Durations in work days for each activity.
- (d) Earliest start date (by calendar date).
- (e) Earliest finish date (by calendar date).
- (f) Latest start date (by calendar date).
- (g) Latest finish date (by calendar date).
- (h) Slack or total float in work days.

The following computer documents shall be prepared as part of the initial Project Schedule submission and each update:

- (a) Activity file sort, including sorts listing activities required of the College and the Architect, such as approvals.
- (b) Eight week "lookahead" detailed bar chart.
- (c) Eight week summary bar chart.
- (d) Additional computer sorts requested by the College.
- (e) High density CDs or thumb drives of all computer files.

8.4 Weather Inclusion In Project Schedule.

Seasonal weather conditions shall be included in the Project Schedule, including average precipitation, temperature and other weather conditions typical in the geographic area over a 5 year period by month.

8.5 Project Schedule Updates.

The Contractor shall prepare Project Schedule updates monthly until the Project is completed. The first update shall be issued 30 calendar days after the Construction Start Date specified in the Notice to Proceed. Updates shall include the following information:

- (a) Actual start and completion dates for activities.
- (b) Activity percent completion.
- (c) Remaining durations for activities in progress.

Each Project Schedule update shall also include a narrative report that includes the following information:

- (a) Summary of Work completed during update period.
- (b) Comparison of actual progress and status to activities and dates in original Project Schedule.

- (c) Analysis of critical path including effect of activity progress on the Project critical path.
- (d) Analysis of secondary critical paths, meaning float within 10 days of the Project critical path.
- (e) Analysis of time lost or gained during the update period.
- (f) Identification of problem areas.
- (g) Identification of change orders and delays impacting or delaying the Project under the Project Schedule.
- (h) Solutions or proposed solutions to current problems and delays.
- (i) Extensions requested by the Contractor, including activities affected and the amounts, and the reasons for the requests.
- (j) Extensions granted by the College for delays and changes, including the activities affected and the amounts, and any effect on the critical path and Contract Milestone, Substantial Completion and Final Completion Dates.
- (k) Delays in activities required of the College and the Architect, and activities that they are required to complete in the update period following the issuance of the update.

All Project Schedule updates must be submitted to the College and the Architect for written approval. Project Schedule updates, including the reports which are approved by the College, shall be deemed to be official records of the progress and status of the Project under the Project Schedule and the Contract, and may be utilized by the College in determining if the Contractor is adequately planning and performing the Work under the Contract Documents.

8.6 Meetings/Eight Week Bar Charts.

The Contractor's Project Manager and Scheduler shall arrange for and attend monthly progress and scheduling meetings with the College and the Architect. Monthly progress meetings shall be scheduled 3 to 7 days after monthly Project Schedule updates and reports are issued and provided to the College and the Architect. The purpose of these meetings will be to review past progress, current status, problem areas, delays, measures to reduce delays, future progress, and the Contractor's most recent Project Schedule update and report. At the monthly progress meetings, the Contractor shall provide a look ahead summary and detailed bar charts showing the Work and activities to be performed and/or completed during the 8 week period following the Project Schedule update.

8.7 Project Schedule Documentation For Contract Payments.

The Contractor will not be entitled to payments under the Contract until a Project Schedule has been submitted to and approved in writing by the College. No payment will be made under the Contract if, when the payment is due, a Project Schedule update and narrative report is due under this Article but has not been submitted to and approved in writing by the College. The original Project Schedule shall include a breakdown allocating the total Contract Price among the network activities in the Project Schedule, which must be approved by the College.

8.8 Progress and Recovery Project Schedules.

The Contractor shall perform its Work in accordance with the Project Schedule. If the Contractor's Work falls behind the requirements of the Project Schedule, it shall, at its own cost, institute measures to improve its progress and bring its Work in compliance with the Project Schedule, including but not limited to increasing manpower, increasing work hours per shift, increasing shifts, increasing working days per week, and rescheduling Work activities to perform them concurrently where feasible.

If monthly Project Schedule updates show that the Contractor's progress has fallen behind the Project Schedule so as to jeopardize the achievement of Milestone, Substantial Completion or Final Completion Dates by more than 10 work days, the Contractor shall, if requested by the College in writing, prepare a recovery schedule with acceleration measures to regain the lost time, and shall proceed in accordance with the recovery schedule in addition to the Project Schedule at its own cost.

8.9 The Contractor's Failure to Provide Project Schedule Updates.

If the Contractor fails to provide monthly Project Schedule updates and reports when required, the College can elect in its sole discretion to employ any of the following remedies: (i) not make progress payments; (ii) on 10 days written notice to the Contractor, retain its own consultant to provide Project Schedule updates and reports and deduct the cost from the Contract Price; (iii) terminate the Contract for default in accordance with the termination provisions in the Contract for Construction and these General Conditions and/or (iv) make a claim on the performance bond.

8.10 Scheduler Qualifications.

The Contractor must utilize a Project Scheduler that satisfies the qualification requirements for the Project. If at any time during the Project it appears that the Contractor's Project Scheduler is not competent to provide the scheduling services required in this Article, the Contractor shall, within 10 days after a written notice and demand from the College, retain a replacement scheduler that is competent to provide the services required. The College may also utilize any of the remedies provided in the Contract for Construction or these General Conditions for the Contractor's failure to provide proper Project Schedule updates and reports.

ARTICLE 9

EXTENSIONS, COMPENSATION FOR CERTAIN EXTENSIONS.

9.1 Delays Warranting Extensions Of Contract Times.

If the Contractor is unavoidably prevented from completing any part of the Work within the Milestone, Substantial Completion or Final Completion Dates by causes beyond the control and without the fault of the Contractor or its Subcontractors, those Contract Times will be extended by amounts equal to the time lost due to such delays, provided the Contractor requests extensions in accordance with this Article. Delays warranting extensions of the Contract Times

include unforeseeable and unavoidable delays caused by the College, the Architect, other contractors employed by the College, utility owners or other third parties, acts of God, acts of governmental authorities, wars, abnormally severe weather conditions of unusual duration (specifically excluding weather conditions of the type and duration that have been encountered in the area in which the Project is located) that prevent timely delivery of materials or equipment necessary to the completion of portions of the Work or hamper access to the Work by workmen or Subcontractors, fires, floods, earthquakes, epidemics, plagues, and other unavoidable casualties.

Apart from an extension of time, no payment or allowance of any kind shall be made to the Contractor as compensation for damages on account of hindrance or delay from any cause in the progress of the Work, whether such delay be avoidable or unavoidable. The Contractor agrees that it will make no claim for compensation, damages for any such delays, and will accept in full satisfaction for such delays said extension of time.

9.2 Weather Delays.

The Project Schedule shall take into account normally anticipatable adverse weather plus an additional five (5) days of severe and unusual weather conditions that will materially interfere with the timely prosecution of the Work. No time extensions will be granted for time lost due to weather conditions that do not meet the criteria set forth in Article 9.1, and then only to the extent more than five (5) days of delay result from such severe and unusual weather conditions. Owner shall not be required to keep a record of days of precipitation or low temperatures and the burden of proof with respect to weather delays shall be upon Contractor. No time extensions will be considered for any weather conditions that do not affect Work on the critical path or Contract Times.

9.3 Float Time Use.

Float time in the Project Schedule is not for the exclusive use of either the Contractor or the College. Float time is available for use by both parties to facilitate the effective use of available resources and to minimize the impact of problems and delays that may arise during construction. No time extension will be granted as a result of any problem, change order or delay which only results in the loss of available positive float on the Project Schedule. Float time shown on the Project Schedule shall not be used by the Contractor in a manner that is detrimental to the interests of the College or the Project.

9.4 Calculation Of Extensions.

Extensions will be calculated based on the effect of delays on the Project Schedule and the activities in the Project Schedule. If the Contractor is entitled to an extension for a delay based on the nature of the delay under this Article, the activities in the Project Schedule affected by the delay will be extended by the amount they are affected. If extensions of activities in the Project Schedule affect the critical path and delay the Contract Milestone, Substantial Completion or Final Completion Dates, they too will be extended to the extent affected. The critical path and Contract Times will only be extended to the extent that they are actually

affected under the Project Schedule by a delay for which the Contractor is entitled to an extension.

If, for any scheduled activity or period, there are concurrent delays that include delays for which the Contractor is entitled to an extension and delays for which the Contractor is not entitled to an extension, the Contractor will be given an extension for the delays for which it is entitled to extension so that it will not be liable to pay liquidated damages for delay, unless the College eliminates or reduces that delay. A concurrent delay will not justify an extension to the Contractor if it has minimal effect on the completion of the Project, and/or if it would likely have been avoided if it had become apparent that it was having an effect on the progress of the Project and the Final Completion Date.

9.5 Elimination of Delays and Extensions (Acceleration).

If the effect of a delay for which the Contractor is entitled to an extension can be reduced or eliminated by changes in the Project Schedule or other measures which have no material adverse impact on the Contractor in terms of cost or otherwise, the Contractor shall employ those measures so that no extension is required or so that a shorter extension is required. If the Contractor is entitled to extensions for delays, and if the College (in its sole discretion) notifies the Contractor in writing that it prefers to eliminate the lost time to avoid or reduce the extension required, by changes or additional efforts such as acceleration efforts, the Contractor shall perform those measures as a change to the Contract to be compensated under the change order provisions in the Contract for Construction and these General Conditions.

9.6 Requests For Extensions Required.

The Contractor must provide the College with a written notice of delay and request for an extension within 24 hours of the beginning of a delay. The written notice of delay and request for extension must include the nature and cause of the delay, the known extent of the delay, the Work activities on the Project Schedule affected by the delay, and the extent of the effect to each, and suggestions or proposals to reduce or eliminate the delay. This limited time frame is to provide the College the opportunity to immediately address the issue and limit the amount of time in the potential delay and its potential impact on the Project Schedule.

9.7 Compensation For Certain Extensions And Limitations.

Under the Contract for Construction and these General Conditions, the College does not assume responsibility for many types of delays, including additional costs resulting from extensions granted because of those delays. Where the College is responsible for a delay under the express terms of the Contract for Construction and these General Conditions, it will pay extra compensation for any extension granted because of the delay.

Compensation by the College for delays (and extensions) for which it is responsible under the Contract for Construction and these General Conditions shall only include additional costs actually incurred at the site, and shall not include home office expense, home office overhead, lost profit or consequential losses. Any additional compensation under this Article shall be subject to the provisions in the Contract for Construction and these General Conditions

regarding claims, and the provisions in the Contract for Construction and these General Conditions regarding the maintenance and availability of cost records.

No compensation will be paid if an extension for a delay for which the College is responsible is concurrent with another delay for which the Contractor is not entitled to an extension, or is concurrent with another delay for which the Contractor is entitled to an extension but the College is not responsible for the other delay.

If the College requests a change in the Contract Work, potential delays and extensions that result from the change and any resulting extra compensation for the change shall be addressed under the change order provisions in the Contract for Construction and these General Conditions in addition to this Article.

ARTICLE 10 **PAYMENTS TO THE CONTRACTOR.**

10.1 Contract Price.

The College will pay the Contractor as full compensation for performing the Work the Contract Price as adjusted by approved change orders that increase or decrease the Contract Price. The College will do so in accordance with this Article, any supplemental General Conditions regarding payment, and the payment terms in the Contract for Construction. Payment provisions in the supplemental General Conditions that add to or modify this Article shall take precedence over this Article. Payment provisions in the Contract for Construction that add to or modify payment terms shall take precedence over the supplemental General Conditions and this Article.

10.2 Monthly Progress Payments.

The College will pay the Contractor monthly progress payments as the Work proceeds and will pay for the Work completed, less retainage. The Contractor shall submit monthly invoices using the College's invoice form for the Work completed in each calendar month, and the monthly invoice shall be submitted in accordance with the Contract. The Contractor shall be entitled to monthly progress payments based on the percentage of the Work completed (less earlier payments), and that amount shall be based on the Unit Schedule Breakdown and the update of the Project Schedule for the billing period showing schedule activities completed and progress on incomplete activities, in conjunction with the values assigned to those activities. If there is a discrepancy between the amount due based on the Unit Schedule Breakdown and the amount due based on the Project Schedule update, the Contractor shall only be entitled to the lesser amount unless the College's Representative, in his/her sole discretion, decides otherwise. Payments made by the College shall be used by the Contractor solely for purposes of this Project and for paying Subcontractors, suppliers, and for labor and materials, and shall not be used to pay debts owed by the Contractor outside of the Project.

10.3 Unit Schedule Breakdown/CPM Activity Price Breakdown.

Before the Contract for Construction is signed, the Contractor shall submit to the College and the Architect a Unit Schedule Breakdown (schedule of values) utilizing the College's form (AIA Documents G702/G703) which reasonably allocates the Contract Price among the principal categories of Work and materials in the Contract. The Unit Schedule Breakdown must be signed by the Contractor and is subject to written approval by the Architect and the College for use in calculating monthly progress payments under the Contract. The Contractor shall not "front end load" the Unit Schedule Breakdown. The Unit Schedule Breakdown may include line items for mobilization, bonds and insurance.

The Contractor's proposed Project Schedule shall reasonably allocate the Contract Price among the activities in the schedule so that monthly Project Schedule updates can be utilized in connection with the Unit Schedule Breakdown in determining the amount of monthly progress payments. The Contractor's Unit Schedule Breakdown and Project Schedule activity price breakdown must be approved in writing by the Architect and the College before any payments are made under the Contract.

10.4 Invoices For Monthly Progress Payments: Form and Content.

The Contractor must utilize the College's invoice form and the invoice forms (AIA Documents G702/G703 and waiver attachments) must be completed before they are submitted for payment. Each invoice must be signed by the Contractor, and shall certify that the Work and materials represented as having been provided have been provided, and that all Subcontractors and suppliers on the Project have been paid all amounts legitimately due for Work and materials billed to the College in earlier invoices that were paid by the College. The Contractor's submission of an invoice constitutes an affirmative representation and warranty by the Contractor that it performed the Work in compliance with the Contract Documents and applicable laws, codes and regulations.

Invoices for monthly Project payments must include the status of the Work in the Unit Schedule Breakdown and the Project Schedule update for the billing period that shows the activities completed or started and the value of them based on the Project Schedule. Invoices must also include certified payrolls for the Contractor and all Subcontractors for the billing period, affirmative action monthly manning reports, a certification of Subcontractor/supplier payments, the College's acknowledgment of progress payment and release of liens and claims form duly executed by the Contractor, the College's acknowledgment of progress payment and release of liens and claims form duly executed by each Subcontractor and supplier who has furnished labor or materials that are the subject of the current invoice, a list of all materials stored to date including descriptions, values, quantities and location, and any other documents required in the Contract Documents.

The Contractor will be entitled to have an invoice paid if the Architect and the College approve in writing the invoice including the percentage of Work completed, and if the quality of the Work and materials conform to the Contract Documents. The approval of invoices shall not waive claims for defects or deficiencies in the Work or materials provided, or the right to subsequently inspect the Project as a complete and functioning whole.

10.5 Payment For Materials And Equipment Procured But Not Installed.

The Contractor may seek payment in monthly invoices for materials and equipment delivered to the Project site but not yet incorporated into the Work. The Contractor shall include with its monthly invoices a list of the stored equipment, the amount and type of stored materials, and the place where they are stored. Each invoice that seeks payment for materials and equipment delivered to the Project site but not installed or incorporated into the Work shall include a signed bill of sale to the College and an invoice from the supplier. All risk of loss or damage for materials and equipment delivered to the Project site shall remain with the Contractor.

The College will only rarely pay for material or equipment stored offsite, and only when it determines, in its sole discretion, that there is good cause. The College will consider no request to pay for materials or equipment stored off site unless the Contractor includes a written request for such payment with its bid for the Project. If the College does agree to pay for material or equipment stored offsite during the performance of the Contract, it will do so when the Contract for Construction is signed.

If the College does agree to pay for materials and equipment stored offsite, such payments shall be subject to any conditions in the signed Contract, and in all cases, a bill of sale to the College, a paid invoice, insurance and proof the storage facility is bonded will have to be provided to the College when each payment is sought. The location will have to be specified in writing and the material or equipment will have to be inspected by the College. The Contractor and its performance bond surety must agree in writing that they retain all risk of loss or damage, and each payment application must contain a consent to payments for materials stored offsite signed by the Contractor's bonding company.

Payments on account of materials or equipment not incorporated into the Work but delivered and suitably stored at the site, or at some other location agreed upon in writing, may be made by the College subject to the following conditions:

- (a) Such materials or equipment shall have been fabricated or assembled specifically for the Project and delivered to storage no earlier than needed for the orderly progress of the Work as demonstrated by the Project Schedule.
- (b) Title to such materials or equipment shall pass to the College pursuant to the Contractor's bill of sale, which shall contain guarantee of replacement thereof in the event of damage thereto or disappearance thereof due to any cause. The Contractor shall also affirm that it will pay for such materials or equipment immediately upon receipt of payment therefore from the College.

In the case of offsite storage, the Contractor shall also provide Consent of Surety to such payment and insurance of such materials or equipment against the perils set forth in these General Conditions both while storage and during transportation to the site. Raw materials or other materials or equipment readily duplicated or usable on other projects will be paid for only

after the materials are incorporated into the construction.

10.6 Retainage.

The College will retain 2% of the amount due on each partial payment pending Final Completion of the Contract.

Retainage amounts being withheld by the College shall be released and paid in full to the Contractor within 45 days of the Final Completion Date agreed upon by the Contractor and the College, without further withholding of any amounts for any purpose whatsoever, provided that the Work has been Finally Completed as indicated.

10.7 Payment For Change Order Work.

The Contractor shall invoice for change order work in the monthly progress payment invoices as the change order work is performed, but may only do so after a written change order has been signed by the appropriate College personnel and a TCNJ Purchase Order is issued by the College.

10.8 Final Payment.

Upon Final Completion of all the Work including all change orders, upon final acceptance of the Work by the Architect and the College, and upon the issuance of the Certificate of Final Completion, the Contractor will be paid the fully adjusted Contract Price including any retainage. The Contractor shall submit an invoice for the final payment. The final invoice must be accompanied by the College's acceptance of final payment and release of liens and claims form duly executed by the Contractor, the College's acceptance of final payment and release of liens and claims form duly executed by each Subcontractor and supplier who has furnished labor or materials that are the subject of the final invoice, all warranties, guarantees, manufacturer literature, approved as-built drawings, shop drawings required, and any other documents that the Contractor is required by the Contract Documents to provide to the College at the time of Final Completion. The final invoice must also include a written signed consent to the final payment signed by the Contractor's bonding company.

10.9 Payment Terms.

All invoices and payments shall be subject to the terms of the Contract for Construction and these General Conditions, including the provisions regarding payments, and to the right of the College to withhold payments or to make deductions from payments for damages, defective work, liquidated damages, third-party claims, failure to complete Work, failure to comply with requirements of the Contract Documents, failure to comply with Prevailing Wage Act requirements set forth in the Contract for Construction and these General Conditions, failure to comply with Project Schedule obligations, or other causes authorized by the Contract Documents.

10.10 Payment Based On Partial Acceptance (Limitation).

The College will not accept portions of the Project as Substantially or Finally Complete unless specified elsewhere in the Contract Documents. If the Specifications authorize partial acceptances, they will also specify the terms and conditions of such acceptances.

10.11 Failure To Pay Amounts In Dispute Not To Affect Performance.

The failure of the College to pay any amount requested by the Contractor in an invoice based on a determination that the invoice is improper or some other dispute shall not entitle the Contractor to stop or slow down the performance of the Work.

10.12 Reasons For Withholding Payment.

In addition to the reasons set forth elsewhere in the Contract for Construction and these General Conditions, the Architect or the College may also withhold payments to the Contractor, or, because of subsequently discovered evidence, may nullify the whole or a part of a payments previously issued to the Contractor, to such extent as may be necessary in the Architect's or the College's opinion to protect the College from loss for which the Contractor is responsible because of

- (a) defective Work not remedied;
- (b) third party claims filed or reasonable evidence indicating probable filing of such claims unless security acceptable to the College is provided by the Contractor;
- (c) failure of the Contractor to make payments properly to Subcontractors or for labor, materials or equipment;
- (d) reasonable evidence that the Work cannot be completed for the unpaid balance of the Contract Price;
- (e) damage to the College or a separate contractor;
- (f) reasonable evidence that the Work will not be completed within the Contract Times, and that the unpaid balance would not be adequate to cover actual or liquidated damages for the anticipated delay;
- (g) failure to comply with requirements for monthly progress payments pursuant to Article 10.4; or
- (h) failure to carry out the Work in accordance with the Contract Documents.

When the above reasons for withholding payment are removed, payment will be made for amounts previously withheld.

If the College withholds or the Architect recommends that the College should withhold payment from the Contractor under subsection (c) above, the College may, after providing the Contractor with written notice and an opportunity to cure, issue joint checks to the Contractor and to any Subcontractor or material or equipment suppliers to whom the Contractor failed to make payment for Work properly performed or material or equipment suitably delivered. However, by doing so, the College is not undertaking any payment obligation on the part of the

Contractor, nor does any Subcontractor have any claims against the College or any right to future joint check payments.

10.13 Set-Off For State Tax Indebtedness.

Pursuant to N.J.S.A. 54:49-19, and notwithstanding any other provision of law to the contrary, if the Contractor or any of its Subcontractors or suppliers are indebted to the State of New Jersey for any State tax, the College may withhold and/or set off any payments due to the Contractor as may be necessary to satisfy such indebtedness and/or pending resolution of the indebtedness.

10.14 Maintenance Of Cost And Accounting Records.

The Contractor shall maintain and retain weekly payroll, material, Subcontractor, supplier, overhead and other cost and accounting records for the Project, and for additional services or extras required by the College, including all costs that the Contractor is entitled to be paid under the Contract. The Contractor shall require its Subcontractors on the Project to do likewise. The Contractor shall also maintain all estimates and takeoffs used in preparing and calculating its bid price for the Contract and change orders. Pursuant to N.J.A.C. 17:44-2.2, the Contractor shall also maintain all documentation related to products, transactions or services under the Contract. The records shall be maintained and shall be made available to the College or its representatives when requested. These records shall be maintained in accordance with generally accepted accounting principles and practices for a period of 5 years after final payment is received by the Contractor, or the duration of any dispute or lawsuit arising out of the Project, whichever is later, and shall be made available to the College or its representatives and the New Jersey Office of the State Comptroller when requested.

Any failure to maintain or produce the records required by this Article shall preclude the Contractor from claiming or being paid or retaining any payments or being paid on any claims that are based on costs or that should be, and expenses or losses incurred by the Contractor or its Subcontractors including extra costs that are or that should be reflected in the records required by this Article or good business practices. This record keeping requirement applies to records related to the basic Contract Price as well as extra compensation for change orders and claims of all kinds.

No claim by the Contractor against the College for payment, whether for Contract Work, extras, changes or claims that is based to any degree on costs that should be recorded in cost records required by this Article or good business practices may be asserted against the College to the extent the cost records do not exist or are not provided to the College upon demand.

The College reserves the right to audit the records of the Contractor and its Subcontractors at any time and for up to 3 years after the Final Completion of the Project. If an audit reveals overpayment by the College, the Contractor shall refund the cost of the audit and the overpayment to the College, or the College may deduct the cost of the audit and the overpayment from future payments under the Contract, or the College may assert claims against the Contractor and/or its surety for the cost of the audit and such overpayments.

10.15 Written Evidence of Payment to Subcontractors.

The College has the right to request written evidence from the Contractor that the Contractor has properly paid Subcontractors and material and equipment suppliers' amounts paid by the College to the Contractor for subcontracted Work. Such evidence shall include acknowledgment of progress payment and release of liens and claims forms duly executed by each Subcontractor and supplier for payments previously made to the Contractor. If the Contractor fails to furnish the College with the written evidence that it has properly paid Subcontractors and material and equipment suppliers, the College shall have the right to contact Subcontractors to ascertain whether they have been properly paid. Neither the College nor Architect shall have an obligation to pay or to see to the payment of money to a Subcontractor, except as may otherwise be required by law. The College may, in its sole discretion, issue checks made payable jointly to the Contractor and a Subcontractor; however, by doing so, the College is not undertaking any obligation on the part of the Contractor, nor does the Subcontractor have any claims against the College nor any right to future joint check payments.

ARTICLE 11 **CHANGES.**

11.1 Changes Authorized.

The College may at any time authorize and direct changes in the Work or accelerations of the Work that change the scope of the Work and that increase or decrease the Contract Price. All changes including changes in the Contract Price shall be governed by this Article. All changes must be in a written change order signed by the Vice President for Administration, the College's Representative, the Architect and the Contractor. A TCNJ Purchase Order will then be issued by the College and signed by the Contracting Officer, after which time, the Contractor can then bill for the completed change order Work. Any extensions in the Contract Times and increases in the Contract Price because of extensions resulting from changes shall be governed by Article 9 of these General Conditions regarding extensions, but the authorization for the extra compensation itself resulting from an extension must be contained in a change order that complies with this Article as well. The College may elect to have changed Work on the Project that is within the scope of the Contract Documents performed by another contractor. Changes in the Work shall not affect the surety bond protection or insurance coverage required by the Contract Documents.

11.2 Change Request Or Directive.

The College may request a change in the Work or materials to be provided under the Contract Documents by a written Contract Change Directive ("CCD") signed by the College's Representative. If the College is of the opinion that no change in the Contract Price or Contract Times is required because of the change request, it shall so state in the CCD. A CCD may include provisions regarding the scope of the changed Work or materials, and may also include conditions including time parameters. A CCD may provide that specified Work shall stop until further notice, but the Contractor shall not stop or delay any Work because of a CCD unless the CCD provides that Work should stop because of the change. A CCD may provide that the performance of changes shall not commence until a change order is issued and a subsequent

TCNJ Purchase Order is issued and signed by the Contracting Officer, or that changed Work should proceed before a change order and TCNJ Purchase Order are issued by the College to maintain the progress of the Project.

11.3 Change Orders Which Are Protested.

If the Contractor protests the terms of a change order, it shall notify the College of its protest in writing within 2 business days of the issuance of the Change Order. It shall describe the terms that it objects to and the reasons for its protest. It shall include supporting documentation if appropriate, including detailed justification for any Contractor requested additional compensation based upon unavoidable additional costs. The College may elect to direct the Contractor in writing to perform the change order requirements despite the protest. If it does so, the Contractor's right to pursue further relief based on the protest shall be preserved and the Contractor shall immediately proceed with the change Work

11.4 Changes Affecting Contract Times.

Changes and change orders shall not affect or extend any of the Contract Times unless the change order itself specifies that it changes Contract Times. If a change order issued by the College delays the completion of any activity in the Project Schedule, the time allowed for that activity shall be extended, and if a delay in that activity delays other activities, the critical path or the Completion Dates in the Contract, they too will be extended. The Contractor shall make reasonable efforts in scheduling changed Work so that it does not delay or extend activities in the Project Schedule critical path, including any Milestone Dates, the Substantial Completion Date and the Final Completion Date. The Contractor shall also make alternate proposals for change order Work that include acceleration for the changed Work where feasible to achieve this goal, and shall include the cost of such efforts in its change order requests and proposals.

Change orders must specify whether they result in any delay (or extension) to any critical path activities in the Project Schedule, including an identification of the activities and the amount of delay in each. If no delay or extension is set forth in a change order, it will be deemed an agreement by the College and the Contractor that no delay or extension results from the change order.

11.5 Contractor Initiated Change Order Requests.

If the Contractor contends that any directive or communication from the College or Architect, or any condition, event or circumstance entitles it to a change order changing the scope of the Work, terms of the Contract Documents, Contract Price or Contract Times, it shall submit a written change order request to the College's Representative within 5 days of the event upon which the request is based. The written request shall specify the terms of the change order requested, and include all documentation and information that the Contractor seeks to have considered in support of the request, or that is necessary to a proper consideration of the request.

11.6 Change Order Amounts.

All price changes or amounts in change orders shall be based on (i) lump sum, (ii) actual work time and materials plus mark-ups for overhead and profit, or (iii) unit prices times actual quantities that may or may not include separate mark-ups for overhead and profit. If a change order price is to be based on a lump sum price or a unit price, the College may request the submission of such documentation regarding market price or cost which it reasonably deems necessary to determine a lump sum or unit price. If a change order is based on actual work time and material costs, it will include a not-to-exceed price.

Applications for payment for change order Work shall be included in monthly progress payment invoices as the change order work is performed, but only after a TCNJ Purchase Order has been issued to the Contractor by the College. For change orders based on time and material costs or unit prices times actual quantities, the time spent, material provided, and quantities performed shall be recorded in daily time slips, material invoices, and quantity of work performed tickets that are signed by the College's Representative to certify that the Work and materials were provided, and the quantities. Labor costs and material costs for change orders shall be based on actual costs to the Contractor without any mark-ups except as provided in this Article.

Mark-ups may be added to time and material costs where a change order is authorized to be paid on a time and material basis, and also unit price change orders if the change order price term expressly authorizes mark-ups as a separate additional charge to be added to the unit price. When mark-ups for overhead and profit are authorized, the standard mark-up for overhead and profit shall be 15% of net costs properly invoiced in the change order. The schedule for mark ups is as follows:

- 15% of direct costs for overhead, profit, bond, and insurance for Work performed directly by the Contractor;
- 15% of direct costs for overhead, profit, bond, and insurance for Work performed directly by the Subcontractor and 5% of the direct and indirect costs of the Work performed by the Subcontractor for the Contractor; and
- 15% of direct costs for overhead, profit, bond, and insurance for Work performed directly by the Subcontractor's subcontractor and 5% of the direct and indirect costs of the Work performed by the Subcontractor's subcontractor for the Subcontractor and 5% of the direct and indirect costs of the Work performed by the Subcontractor for the Contractor.

There shall be no additional mark-ups for materials or supplies. Bond and insurance costs are included in the noted mark ups above. Refer to Division 1 Specifications also for further delineation of items included in mark-ups.

THE CONTRACTOR MUST USE THE COLLEGE'S CHANGE ORDER FORM INCLUDED IN THE PAYMENT PROCEDURE DOCUMENTS.

11.7 Right To Audit Extra Costs (Before And After Payment).

The College reserves the right to audit all change orders and additional costs claimed and/or paid under the Contract at any time. The obligation of the Contractor, Subcontractors and suppliers to establish, maintain and produce cost records and remedies for failing to do as specified elsewhere in these General Conditions and the Contract for Construction shall govern. If an audit reveals that actual costs invoiced to the College and/or paid by the College in change orders exceed the actual costs incurred, the Contractor shall refund the excess, or the College may deduct the excess from future payments under the Contract, or the College may assert claims against the Contractor and/or its surety for such overpayments.

11.8 Change Orders With Both Price Increases and Decreases.

If a change order reduces the scope of the Work or materials to be provided by the Contractor under the Contract, the change order shall provide for a reduction in the Contract Price in the amount of the actual reduction in cost. If a change order results in both added costs and reduced costs, they shall be combined for a net plus or minus Contract Price adjustment, and when mark-ups are applicable, they shall only be added to a net increase in the Contract Price which results from a combination of additions and deductions in the change order.

11.9 Waiver Of Rights In Connection With Change Orders Issued Without Protest.

The Contractor shall not be entitled to seek any additional compensation or any extension of the Contract Times beyond the amounts and any extensions included in a change order signed by the College or a written change order request submitted by the Contractor to the College for approval, the intent being that the Contractor must disclose all additional costs and delays claimed to result from a change so that the College can take measures in considering the change to effect cost savings and avoid delays. The failure to include extra costs or delays in a change order request will preclude the Contractor from later claiming such costs or delays in connection with the change in any form or fashion.

ARTICLE 12 COMPLETION.

12.1 Substantial Completion.

When the Contractor believes that the Project (or a specific phase of the Work, if the Work is to be performed in phases) is Substantially Complete, meaning all essential requirements of the Work have been sufficiently completed so that the Project (or a specific phase) can be occupied and used for its intended purpose (and as further defined in the College's Division 1 specifications for capital projects), it can make a written request to the Architect and the College to conduct an inspection and to issue a Certificate of Substantial Completion. The Contractor's request shall list all Work and requirements of the Contract Documents that remain to be completed or corrected and an estimate of the value of the incomplete items and the dates by which those items of the Work will be completed, but in no event shall it be more than thirty (30) days from Substantial Completion.

The Architect and the College will conduct an inspection, and if they determine the Contractor has Substantially Completed the Project (or a specific phase of the Work, if the Work is to be performed in phases), the College will issue a Certificate of Substantial Completion. If the Architect and the College determine that the Contractor has not achieved Substantial Completion, the College will notify the Contractor in writing and will list the Work and requirements of the Contract Documents that must be completed for Substantial Completion and provide a punchlist. The Architect and the College will also assign a value to the incomplete items to be added to the 2% retainage held after the Certificate of Substantial Completion is issued. The College and the Architect will re-inspect when the Contractor notifies them in writing that those items have been completed.

Any failure of the College or Architect to include incomplete or deficient items in a Certificate of Substantial Completion or a notice regarding a Substantial Completion inspection shall not affect the Contractor's obligation to properly complete all requirements of the Contract.

The College will not issue a Certificate of Substantial Completion unless it can occupy and use the Project (or the phase of the Work) for its intended purpose, and the Contractor agrees that the College's use and occupancy of the Project (or the phase of the Work) shall not affect the Contractor's obligation to complete the Project and requirements of the Contract Documents. The Contractor also agrees that its completion of the Project will not unreasonably interfere with the College's occupancy and use of the Project (or the phase of the Work) and that the College's occupancy will not impede the Contractor's completion of the Work to Final Completion.

Unless otherwise specified in the supplemental General Conditions, a Certificate of Substantial Completion will not be issued unless an unqualified temporary or permanent certificate of occupancy is issued, and the College is able to use and occupy the Project (or the phase of the Work) without interruption.

The issuance of a Certificate of Substantial Completion shall not void or alter any of the other terms of the Contract Documents, including but not limited to terms relating to warranties, or relieve the Contractor of its obligation to complete the Work or remedy defective Work or materials, unless such terms are expressly modified by the Certificate of Substantial Completion.

Guarantee periods for equipment, workmanship and materials shall commence when the Certificate of Substantial Completion is issued or from the completion and acceptance of equipment, workmanship or materials, whichever is later, unless otherwise specified in the supplemental General Conditions or the Certificate of Substantial Completion.

The rights of the Contractor regarding payments upon the issuance of the Certificate of Substantial Completion shall be as provided in the payment provisions of the Contract for Construction and these General Conditions.

12.2 Final Completion.

The Contractor shall notify the Architect and the College in writing when it has completed the entire Project (or a specific phase of the Work, if the Work is to be performed in

phases) and has satisfied all of the requirements of the Contract Documents for Final Completion. The Architect and the College will then conduct an inspection, and if they determine that the Contractor has completed the entire Project (or a specific phase of the Work, if the Work is to be performed in phases) and has satisfied all of the requirements of the Contract Documents for Final Completion, the College will then issue a Certificate of Final Completion. If any items remain incomplete or unsatisfactory, the College will notify the Contractor in writing and list the incomplete or unsatisfactory items. The Contractor shall immediately complete and correct any unfinished items and notify the Architect and the College in writing and request a follow-up inspection for Final Completion.

The Certificate of Final Completion will not be issued until all documents required by the Contract Documents have been provided, including the College's acceptance of final payment and release of liens and claims forms duly executed by the Contractor and any Subcontractors and suppliers who have furnished labor or materials under the Contract, warranties, maintenance and operating instructions, certificates, insurance, shop drawings required, and as-built drawings approved by the Architect. Final Completion must include leaving the entire Project site and the Project (or the phase of the Work) clean, neat and orderly. All distortions, cracks, delaminating and deteriorations of finished surfaces must be remedied. All broken items shall be repaired. All paint spots, stains and plaster must be removed. All unused equipment and excess material shall be removed. The Project and the Project site (or the phase of the Work) shall be clean and finished.

If the Contractor unreasonably delays completing and correcting items needed for the issuance of the Certificate of Final Completion, the College may unilaterally issue a Certificate of Final Completion that lists incomplete and defective items, and that deducts any applicable liquidated damages and the cost of remedying incomplete and defective items from the final amount due to the Contractor under the Contract.

Final payment will not be made until the Certificate of Final Completion is issued, and the final payment shall be subject to the payment provisions in the Contract for Construction and these General Conditions.

ARTICLE 13 **SUSPENSION AND TERMINATION OF CONTRACT.**

13.1 Suspension By The College.

The College shall have the right to stop or suspend the Work in whole or in part at any time. The Work may only be stopped or suspended by a written directive of the College's Representative, except in an emergency. The College's Representative may stop or suspend the Work in whole or in part on an emergent basis, either verbally or in writing, but any such emergent suspension or stop Work order shall be confirmed by a written directive from the College's Representative within 48 hours. The College may stop or suspend the Work because of any conditions affecting health or safety on or off site, any dangerous condition, any environmental hazard, the convenience of the College, or the public interest. If a directive to

stop or suspend all or part of the Work includes directions to secure the site, the Contractor shall perform the Work required in the directive. The Contractor shall also maintain the safety and security of the Project during the suspension for the protection of the site, Work in place, materials and equipment on site, persons on or near the site, and the College's property.

If all or part of the Work is suspended in response to a problem or condition caused by the Contractor's performance of its Contract, or parties other than the College itself, or conditions over which the College has no control, the Contractor will not be entitled to any additional compensation for the suspension. If the College directs the suspension of Work because of the improper performance of the Contract by the Contractor or those performing its Contract, the Contractor will not be entitled to any extension of any Contract Times or additional compensation by reason of the suspension. If a suspension is directed for reasons other than the fault of the Contractor or others involved in its performance of the Contract, the Contractor will be entitled to an extension under and to the extent authorized in Article 9, and additional compensation under and to the extent authorized by Article 11.

13.2 Termination For Convenience.

The College may, by a written directive, terminate the Contract at any time before completion for the College's convenience or where it concludes that it is in the public interest to do so. The Contractor shall complete any items of Work specified in the notice of termination for convenience and any Work necessary to make the site safe for all persons and property at or near the Project site when the College terminates the Contract for convenience under this Article.

Absent the Contractor fault or violation of the Contract, the Contractor shall be paid in full for all properly completed Work, subject to the payment provisions in the Contract for Construction and these General Conditions. The Contractor will not be entitled to payment for costs and mark-ups for Work or materials not provided before the termination, or costs for Work and materials not provided unless the Contractor cannot avoid liability to pay those costs, or profit or overhead on the portion of the Contract that will not be performed because of the termination, or other types of damages. The extra compensation payable to the Contractor in connection with a termination for convenience may include the cost of materials or equipment purchased for the Project before termination but not installed if the Contractor cannot otherwise use or sell them.

The Contractor will also be entitled to reasonable termination costs in reasonable amounts for additional direct costs in connection with the termination, but not administrative, home office or overhead costs, lost profit, or consequential damages. In addition, any claims shall be subject to the provisions in the Contract for Construction and these General Conditions regarding claims and the maintenance of cost records.

The Contractor shall include provisions similar to this Article in subcontracts and supply contracts for the Project. When a termination for convenience is directed by the College, the Contract shall be closed out in accordance with the provisions of the Contract for Construction and these General Conditions regarding payment and Project completion.

13.3 Termination For Cause.

The College may terminate the Contract for cause if the Contractor (i) commits violations of the Contract Documents, (ii) fails to perform the Work in accordance with the Contract Documents including the Project Schedule, (iii) fails to comply with applicable laws, rules or regulations, (iv) fails to pay Subcontractors or suppliers to the extent reasonably required, (v) becomes insolvent or becomes a debtor in a bankruptcy proceeding, (vi) fails to pay its debts, (vii) is found to have made false or misleading statements to the College in writing in obtaining the Contract or payments, (viii) fails to comply with employment discrimination laws, (ix) fails to pay prevailing wages, (x) fails to maintain or renew the required insurance, (xi) fails to maintain proper protection for the safety of persons or property on the site, (xii) fails to comply with reasonable and authorized directives of the College under the Contract, or (xiii) assigns its rights or interests under the Contract or payments under the Contract to any third party.

If the College terminates the Contract for cause, it shall first send a notice of intent to terminate to the Contractor and the Contractor's surety. The notice shall direct the Contractor to remedy or eliminate the deficiency within a specified time if the problem is one that can be eliminated. If the Contractor fails to reasonably comply with the directive and notice, the College may after 10 days issue a notice of termination to the Contractor and its surety which terminates the Contract effective immediately and specifies the reason for the termination.

If the Contract is terminated, the Contractor shall secure the site and take measures to leave the site safe for persons, material, Work in place and equipment before departing the site, and shall remove all tools and equipment within 5 days of the termination effective date. The Contractor shall not remove any materials or equipment stored on site unless directed to do so by the College. When the Contract is terminated, the Contractor shall deliver materials purchased for the Project and paid for by the College, but not stored on site, together with all appropriate warranties and guaranties to any location designated by the College.

If the Contractor's surety does not take over the completion of the Work in accordance with this Article, the College may appropriate any or all materials on the site that may be suitable and acceptable and may enter into an agreement for the completion of the Work with another contractor, or use other methods to complete the Work.

All damages, costs and charges incurred by the College together with the cost of completing the Work, will be deducted from any monies due or which may become due to the Contractor for Work properly completed by it before the termination. If such expenses exceed the sum available from the unpaid Contract Price, the Contractor and its surety shall be liable and shall pay to the College the amount of such excess in addition to other damages.

The rights and remedies of the College in connection with a termination for cause shall be in addition to other rights and remedies which it has under law, the Contract, and the Contractor's bond.

If the College terminates the Contract for cause and it is subsequently determined by a court that the Contractor was not in default, or that the termination was legally unjustified, the termination will be deemed to be a termination for convenience under this Article, and the rights

and remedies of the Contractor and its surety for the termination will be limited to those which exist in connection with a termination for convenience. If the College terminates the Contract for cause, the Contractor may not file a suit to recover on any claims arising out of the Project before the Work is Substantially Complete.

13.4 Surety Takeover Following Termination For Cause.

If the College terminates the Contractor for cause, the Contractor's performance bond surety may elect to takeover and complete the Contractor's Work and obligations under its Contract. If the surety elects to take over the completion of the Contract, it may only do so on the following conditions:

- (a) The surety must notify the College that it will take over completion of the Contract by a written notice of intent signed by a representative authorized to bind the surety within 5 calendar days of the surety's receipt of the College's notice of termination.
- (b) The surety and the College must execute a written takeover agreement within 10 days after the surety sends its notice of intent to takeover. The takeover agreement signed by the surety and the College, must:
 - i. contain an acknowledgement and agreement by the surety to assume the obligation to complete the balance of the Work under the Contract and to perform all of the Contractor's obligations under the Contract at the surety's sole cost and expense, and to utilize only contractors approved by the College to complete the Work, which approval shall not be unreasonably withheld;
 - ii. provide that the surety is entitled to be paid the unpaid balance under the terminated Contractor's Contract in accordance with and subject to the terms of the Contract for Construction and these General Conditions;
 - iii. provide that the surety is not relieved of any of its obligations under its payment and performance bond for the Project, and that the College retains its right to withhold money for Contract payments to compensate for damages or for other reasons where authorized under the Contract for Construction or these General Conditions; and
 - iv. provide that it is without prejudice to and is subject to all of the rights and remedies of the College, the surety, and the defaulted Contractor, and the surety may not require the College to agree to a takeover agreement that seeks to extinguish any such rights.
- (c) The surety must also pay without delay all obligations of the terminated Contractor for Work and materials on the Project, subject to a reasonable allowance of time to investigate and verify claims.

13.5 Suspension By The Contractor For Non-Payment.

If the Contractor is not paid sums due under an approved invoice within thirty (30) days of the billing date, it may suspend performance without penalty for breach of Contract, but only

after providing the College with 7 days written notice of non-payment, and only in the event that the College fails to furnish the Contractor, within that 7 day period, with a written statement of the amount withheld and the reasons for the withholding. Nothing herein shall be construed to excuse the Contractor's nonperformance, or to limit the College's rights and remedies relating to such nonperformance, with regard to any monies withheld from the Contractor upon the proper notice provided under this Article, or with regard to any Contractor claim disputed by the College.

ARTICLE 14
WARRANTY/DEFECTIVE WORK AND MATERIALS

14.1 General Work One Year Warranty; HVAC Systems Two Year Warranty

The Contractor warrants and guarantees for a one year period that all Work, materials and equipment (and for a two year period that all HVAC work) conform to the Contract Documents and will not fail or manifest defects, that the Project and all its components will be fit for their intended functions, and that all material and equipment will be new and of good quality.

The general one year warranty period (or two year warranty period for HVAC work) shall commence when the Certificate of Substantial Completion is issued, and the one year period (or two year period for HVAC work) shall commence on that date for all components of the Project, including any equipment activated and operated before Substantial Completion, such as HVAC systems, electrical systems and elevators.

During the one year warranty period (or two year warranty period for HVAC work), the Contractor shall repair and remedy at its own expense any premature failure, defects or deficiencies in any Work, materials or equipment that are discovered or that develop during the one year period (or two year period for HVAC work), and shall do so within 5 days after receipt of a written warranty claim from the College. The Contractor shall also repair damages caused by any failure or defect covered by this warranty. A failure to provide the warranty service required shall constitute a breach of this warranty obligation as well as other applicable provisions of the Contract. This warranty shall not cover failures caused solely by substantial misuse or abuse by the College.

This general one year warranty (or two year warranty for HVAC work) is intended to provide the College with prompt warranty service for all aspects of the Project for the one year period (or two year period for HVAC work). It is not intended to limit or extinguish any additional warranties required by any of the Contract Documents, or provided by manufacturers of systems, equipment or materials provided under the Contract. It is not intended to eliminate or reduce the College's rights and remedies under the Contract Documents and law for defects and deficiencies in the Work, materials and equipment, or the time period of the Contractor's general responsibility and liability.

14.2 Defective Work, Materials And Equipment.

Apart from the general one year warranty (or two year warranty for HVAC work) provided for in this Article, the Contractor shall be responsible for defective Work, materials and equipment and any failure of these items to comply with the Contract Documents. This obligation shall extend beyond Substantial Completion, Final Completion and the general one year warranty (or two year warranty for HVAC work) in this Article.

If defects in the Work, materials or equipment or non-conforming items are discovered during construction and before Final Completion, the Contractor shall promptly correct them at its own expense. If the Contractor fails to correct defective or non-conforming Work, material or equipment in response to a written notice from the College, either during construction or after Final Completion, the College may employ others to provide the remedial work and the Contractor and its surety shall be liable for the cost thereof and damages incurred by the College. The Contractor and its surety shall also be liable for the cost of making good all Work and material destroyed or damaged by defects or the correction of defects.

If any portion of the Contractor's Contract Price remains in the custody of the College, either earned or unearned, the College may deduct money paid to others to remedy defects after notice is sent to the Contractor and damages incurred by the College when the Contractor fails to provide a remedy in response. The Contractor's responsibility for defects and non-conforming Work, material and equipment shall not be limited in time except by applicable law.

The Contractor's responsibility for defective Work shall not be affected by either the performance or the lack of performance of inspections by the College or the Architect. The issuance of payments, a Certificate of Substantial Completion or a Certificate of Final Completion shall not constitute acceptance of Work, material or equipment that is deficient or not in compliance with the Contract, or limit the Contractor's warranty or the other Contract obligations.

ARTICLE 15

INDEMNIFICATION/LIABILITY TO THIRD PARTIES.

15.1 The Contractor's Indemnification Obligation.

To the fullest extent permitted by law, the Contractor shall defend, indemnify, and hold harmless the College, the State of New Jersey, the New Jersey Educational Facilities Authority, Trenton State College Corporation, and any other persons or entities designated by the College, and the officers, directors, principals, attorneys, agents, servants, and employees of any of them (collectively the "Indemnified Parties") from and against claims, damages, losses and expenses, including but not limited to attorneys' fees, arising out of or resulting from: (1) performance of the Work, whether such claim, damage, loss or expense is attributable to bodily injury, sickness, disease or death, or to injury to or destruction of tangible property, including loss of use resulting therefrom caused in whole or in part by the negligent or willful acts or omissions of the Contractor, Subcontractor, anyone directly or indirectly employed by them, or anyone for whose acts they may be liable, regardless of whether or not such claim, damage, loss or expense is caused in part by a party indemnified hereunder or (2) any one or more of the items set forth in

this Article. Such obligation shall not be construed to negate, abridge, or reduce other rights or obligations of indemnity which would otherwise exist as to a party or person described in this Article.

In claims against any person or entity indemnified under this Article by an employee of the Contractor, a Subcontractor or anyone directly or indirectly employed by them or anyone for whose acts they may be liable, the indemnification obligation under this Article shall not be limited by a limitation on amount or type of damages, compensation or benefits payable by or for the Contractor or Subcontractor under workers' compensation acts, disability benefit acts or other employee benefit acts, nor shall the same be limited by the types or limits of insurance carried or to be carried by the Contractor or any Subcontractor pursuant to the Contract Documents or otherwise.

The indemnity, defense, and hold harmless obligation set forth in this Article shall be supplemented by the following:

- (a) any claims or liens of Subcontractors, except to the extent that the non-payment upon which the claim or lien is predicated resulted solely from the College's wrongful failure to pay the Contractor sums due under the Contract;
- (b) any fines, penalties, liquidated damages, assessments or other executions imposed by any governmental authority having jurisdiction over the Project by reason of the Contractor's failure to comply with any requirement of the Contract;
- (c) any losses, damages, or expenses incurred by reason of the Contractor's failure to obtain and maintain in force or cause to be obtained and maintained, the insurance required by the terms of the Contract;
- (d) any losses, damages, or expenses incurred by reason of any failure (whether or not specifically identified herein) by the Contractor to perform its obligations under the Contract Documents or any breach of the Contract;
- (e) any claims, damages, or expenses incurred by reason of the Contractor's infringement or alleged infringement of any patent, copyright, or other intellectual property or similar rights; and
- (f) any claims, damages, liquidated damages, penalties, or fines assessed against the College, directly or indirectly, solely or partially by reason of the Contractor's failure to comply with any applicable laws, codes, statutes, or regulations.

If any judgment is rendered against the Indemnified Parties for which indemnification is required under this Article, the Contractor shall satisfy and discharge it. The Contractor shall reimburse the College for reasonable attorney fees, costs and expenses incurred by the Indemnified Parties in the defense of such suit or claim.

The College shall give written notice to the Contractor of claims and suits for which indemnification may be claimed pursuant to this Article.

The foregoing obligations shall survive the completion of the Work and final payment to the Contractor (or the sooner termination of the Contract) with respect to all matters accrued during the term of the Contract and such obligations shall not be construed to negate, abridge or reduce any other rights, obligations or indemnity which would otherwise exist as to a party or person indemnified by this Article.

15.2 The Subcontractor's Indemnification Obligation.

The Contractor shall cause the indemnification obligations set forth in this Article to be included in all contracts with its Subcontractors.

ARTICLE 16 **INSURANCE AND BONDS.**

16.1 The Contractor's Insurance.

The Contractor shall purchase from, and maintain with a company or companies lawfully authorized to do business in the State of New Jersey, insurance for protection from claims under workers' compensation and other employee benefit acts which are applicable, claims for damages because of bodily injury, including death, and claims for damages, including the Work itself, to property which may arise out of or result from the Contractor's operations and completed operations under the Contract, whether such operations be by the Contractor or by a Subcontractor or anyone directly or indirectly employed by any of them, until at least 1 year after the Final Completion and acceptance of the Project. This insurance shall be written for not less than the limits set forth below or as required by law, whichever coverage is greater, and shall include contractual liability insurance applicable to the Contractor's obligations under Article 15 (Indemnification). The Contractor expressly agrees that any insurance protection required by the Contract Documents shall in no way limit the Contractor's obligations under the Contract, and shall not be construed to relieve the Contractor from liability in excess of such coverage. Nor shall it preclude the College from taking such actions as are available to it under any other provisions of the Contract for Construction, these General Conditions or the law.

16.1.1 Types and Minimum Amounts of Insurance:

- (a) **Commercial General Liability Insurance (CGL).** Commercial General Liability insurance ISO 1088 or later occurrence form of insurance including contractual liability with limits of at least _____ dollars (\$ _____) combined single limit for bodily injury and property damage liability for each occurrence. The CGL policy shall also include products/completed operations with limits of at least (\$ _____) per occurrence. This insurance shall be maintained for at least 1 year after the Final Completion of the Project.
- (b) **Automobile Liability Insurance.** Comprehensive Automobile Liability insurance covering owned, non-owned, and hired vehicles. The limits of liability shall not be less than _____ dollars (\$ _____) combined single limit for bodily injury and property damage for each occurrence.

- (c) **Workers Compensation/ Employer's Liability.** Worker's Compensation Insurance applicable to the laws of the State of New Jersey and other State or Federal jurisdictions required to protect the employees of the Contractor and any Subcontractor, sub-subcontractor or supplier who will be engaged in the performance of the Contract. The certificate must so indicate that no proprietor, partner, executive officer or member is excluded. This insurance shall include Employers' Liability Protection with a limit of liability not less than one million dollars (\$1,000,000) bodily injury, each occurrence, one million dollars (\$1,000,000) disease, each employer, and one million dollars (\$1,000,000) disease, aggregate limit.

All required insurance coverages must be written by insurance companies acceptable to the College. All insurance companies must have a minimum A.M. Best's financial strength rating of A- or better, or an equivalent rating from another respected rating agency, and an A.M. Best's size rating of VII or greater.

16.1.2 Additional Insureds. All insurance required herein, except Worker's Compensation, shall name The College of New Jersey, the State of New Jersey, the New Jersey Educational Facilities Authority, Trenton State College Corporation and any other persons or entities designated by the College as additional insureds.

16.1.3 Cancellation. The certificates of insurance shall provide for 30 days written notice to the College before any cancellation, expiration or non-renewal during the term the insurance is required by the Contract.

16.1.4 Evidence of Insurance. The Contractor shall when the Contract for Construction is signed and before beginning the Work required under the Contract, provide the College with valid certificates of insurance signed by an insurance provider or authorized agent or underwriter to evidence the Contractor's insurance coverage as required in this Article, and also copies of the policies themselves. The certificates of insurance shall specify that the insurance provided is of the types and in the amounts required in this Article, and that the policies cannot be canceled except after 30 days written notice to the College. The Contractor shall also be required to provide the College with valid certificates of renewal when policies expire. The Contractor shall also, when requested, provide the College with additional copies of each policy and all endorsements required under the Contract, which are certified by an agent or underwriter to be true copies of the policies and endorsements issued to the Contractor.

16.1.5 Remedies for Lack of Insurance. If the Contractor fails to renew any of its required insurance policies, or any policy is canceled, terminated or modified, the College may refuse to pay monies due under the Contract. The College, in its sole discretion and for its sole benefit, may use monies retained under this Article to attempt to renew the Contractor's insurance or obtain substitute coverage if possible for the College's sole benefit, and may invoke other applicable remedies under the Contract for Construction and these General Conditions including claims against the Contractor and its surety. During any period when the required insurance is not in effect, the College may also, in its sole discretion, either suspend the Work under the Contract or terminate the Contract.

16.2 The Subcontractor's Insurance.

The Contractor shall ensure that its Subcontractors purchase and maintain insurance on the same terms and with coverages customary for each trade as required by the Contractor under the Contract. The Contractor shall contractually obligate its Subcontractors to indemnify, defend, and hold harmless the College upon the same terms and conditions that the Contractor is required to do so as provided in Article 15 of these General Conditions (Indemnification).

16.3 Payment And Performance Bond.

The Contractor is required to furnish the College with a payment bond and a performance bond from an approved surety as described in this Article and in the bid documents. The bonds shall conform to N.J.S.A. 2A:44-147. The Contract will not become effective until these bonds are provided to and approved in writing by the College. The bonds must also be accompanied by the surety disclosure statement and certification required by N.J.S.A. 18A:64-68.

ARTICLE 17 **DISPUTE RESOLUTION.**

17.1 Mediation.

If a dispute or claim arises out of or relates to the Contract, or the breach thereof, and if the dispute cannot be settled through negotiation, the dispute or claim may, at the College's sole option, be subject to mediation administered by the American Arbitration Association under its Construction Industry Mediation Rules as a condition precedent to binding dispute resolution. The parties shall share the mediator's fee and any filing fees equally. The mediation shall be held in Mercer County, New Jersey, at the offices of the College's attorneys, unless another location is mutually agreed upon. Agreements reached in mediation shall be enforceable in any court having jurisdiction thereof.

17.2 Method Of Binding Dispute Resolution.

For any dispute or claim, not resolved by mediation pursuant to this Article, the method of binding dispute resolution shall be litigation in the state or district courts of the State of New Jersey, unless the College, in its sole discretion, decides to submit the dispute or claim to arbitration pursuant to this Article.

17.3 Arbitration (If The College Elects To Arbitrate).

If the College decides, in its sole discretion, to submit a dispute or claim to arbitration rather than litigation as provided above, the arbitration shall be administered by the American Arbitration Association in accordance with its Construction Industry Arbitration Rules in effect on the date of the Contract unless the parties mutually agree otherwise. A demand for arbitration shall be made in writing, delivered to the other party to the Contract, and filed with the person or entity administering the arbitration. The arbitrator shall be a New Jersey licensed attorney with at least twenty (20) years' experience practicing in construction law. In the event that the parties mutually agree to use a panel of three arbitrators, then the construction attorney will be the

presiding arbitrator, one of the arbitrators will be a registered architect and the other will be a contractor, all of whom shall be neutral and independent. This Article shall not preclude the College or Contractor from instituting legal action to discharge an invalid construction lien. The arbitration hearing shall be held in Mercer County, New Jersey, at the offices of the College's attorneys, unless another location is mutually agreed upon.

A demand for arbitration shall be made no earlier than concurrently with the filing of a request for mediation, but in no event shall it be made after the date when the institution of legal or equitable proceedings based on the claim, dispute or other matter in question would be barred by the applicable statute of limitations. For statute of limitations purposes, receipt of a written demand for arbitration by the person or entity administering the arbitration shall constitute the institution of legal or equitable proceedings based on the claim, dispute or other matter in question.

The foregoing agreement to arbitrate and other agreements to arbitrate with an additional person or entity duly consented to by the parties to the Contract shall be specifically enforceable in accordance with applicable law in any court having jurisdiction thereof.

The award rendered by the arbitrator(s) shall be a reasoned award and shall include a statement of findings of fact and conclusions of law and shall be final, and judgment may be entered upon it in accordance with applicable law in any court having jurisdiction thereof.

17.4 Consolidation Or Joinder.

The College, in its sole discretion, may consolidate an arbitration conducted under the Contract with any other arbitration to which it is a party provided that (i) the arbitration agreement governing the other arbitration permits consolidation, (ii) the arbitrations to be consolidated substantially involve common questions of law or fact, and (iii) the arbitrations employ materially similar procedural rules and methods for selecting arbitrator(s).

The College, in its sole discretion, may include by joinder persons or entities substantially involved in a common question of law or fact whose presence is required if complete relief is to be accorded in arbitration, provided that the party sought to be joined consents in writing to such joinder. Consent to arbitration involving an additional person or entity shall not constitute consent to arbitration of any claim, dispute or other matter in question not described in the written consent.

The College, in its sole discretion, may grant to any person or entity made a party to an arbitration conducted under this Article, whether by joinder or consolidation, the same rights of joinder and consolidation as the College under the Contract.

17.5 Work During Pendency Of Dispute.

Unless otherwise instructed by the College, the Contractor shall carry on its Work during the pendency of any dispute hereunder, and the College shall continue making payments to the Contractor of undisputed amounts.

17.6 Prompt Payment Claims.

Notwithstanding the foregoing, disputes regarding only whether a party has failed to make payments required pursuant to New Jersey's Prompt Payment Act may be submitted to alternative dispute resolution as provided in N.J.S.A. 2A:30a-2(f). In such event, the College and the Contractor shall share equally the fees and expenses of the selected mediator. Provided, however, that nothing herein shall be construed, in whole or in part, as a waiver, release or modification of the provisions of the New Jersey Contractual Liability Act, N.J.S.A. 59:13-1, et seq., as it governs claims against the College.

17.7 The Contractor's Claims: Procedures And Limitations.

Claims by the Contractor against the College shall be subject to the New Jersey Contractual Liability Act, N.J.S.A. 59:13-1, et seq., including the notice and time for suit provisions. For the purpose of determining the time within which the Contractor must file suit under the New Jersey Contractual Liability Act, "completion of the contract" shall be deemed to have occurred upon achievement of Substantial Completion as defined in these General Conditions.

The Contractor also agrees that it shall not be entitled to assert claims against the College for any compensation beyond that provided for in the Contract by reason of the acts or omissions of any third parties, including but not limited to the Architect and any other contractor on the Project. The Contractor may not assert claims for extra costs for home offices expenses, home office overhead, lost profits or revenue, or consequential damages as that term is defined in law. All claims shall also be subject to all other pertinent provisions of the Contract for Construction and the Contract Documents including these General Conditions. The Contractor also agrees that it may not assert any claims for extra costs or damages unless it maintains all the records of its estimated and actual costs as required by the Contract for Construction and these General Conditions.

17.8 Dispute Resolution Process In The Contractor's Subcontracts.

The Contractor shall include this dispute resolution process in all of its contracts with any Subcontractors or suppliers on this Project.

ARTICLE 18 **MISCELLANEOUS.**

18.1 Prevailing Wage.

The Contractor and its Subcontractors shall comply with the New Jersey Prevailing Wage Act, N.J.S.A. 34:11-56.25 through 56.57. Workers employed by the Contractor or any Subcontractor or sub-subcontractor in the performance of services directly on the Project must be paid prevailing wages. As required by N.J.S.A. 34:11-56.27 and 56.28, the Contract cannot become effective until the College obtains from the New Jersey Department of Labor a determination of the prevailing wage rates applicable to the Project as of the Contract award date and attaches a copy to the Contract. As required by N.J.S.A. 34:11-56.27, the Contractor or any

Subcontractor may be terminated if any covered worker is not paid prevailing wages on the Project, and the Contractor and its surety shall be liable for any additional costs which result. The Contractor and its Subcontractors must be registered with the New Jersey Department of Labor (N.J.S.A. 34:11-56.51 et seq.), and the prevailing wage rates must be posted at the job site (N.J.S.A. 34:11-56.32). The Contractor and its Subcontractors must prepare accurate certified records of wages paid for each worker on the Project (N.J.S.A. 34:11-56.29), and copies for the period covered by each invoice must be attached to the invoice submitted under the Contract. In accordance with N.J.S.A. 34:11-56.33, the Contractor's final invoice must include a statement of all amounts still then due to workers on the Project. The Contractor is also cautioned that it must use job titles and worker classifications consistent with those approved by the Department of Labor, and that, if it intends to pay apprentice rates, it must comply with the Department of Labor's regulations at N.J.A.C. 12:60-7.1 through 7.4.

If the State's Prevailing Wage Act is amended, or the language stated herein is inconsistent with the language contained in the State's Prevailing Wage Act, the language of the State's Prevailing Wage Act shall control.

18.2 Employment Discrimination.

The Contractor and any Subcontractors employed by it shall comply with N.J.S.A. 10:2-1 through 10:2-4 and N.J.S.A. 10:5-1 et seq., including N.J.S.A. 10:5-31 through 10:5-35, which prohibit discrimination in employment in public contracts. The statute and the rules and regulations promulgated thereunder shall be considered to be part of the Contract and binding upon the Contractor and its Subcontractors. If the College is notified of any violation of the public contract awarding regulations in accordance with N.J.A.C. 17:27-7.4 concerning the financing of minority and women outreach and training programs, the College reserves the rights to deduct the outreach and training allocation from the Contract. During the performance of the Contract, the Contractor agrees that:

- (a) In the hiring of persons for the performance of Work under the Contract or any subcontract hereunder, or for the procurement, manufacture, assembling or furnishing of any such materials, equipment, supplies or services to be acquired under the Contract, neither the Contractor, its Subcontractors nor any person acting on behalf of the Contractor or any of its Subcontractors, shall, by reason of race, creed, religion, color, national origin, nationality, ancestry, age, sex (including pregnancy), familial status, marital status, domestic partnership or civil union status, affectional or sexual orientation, gender identity or expression, atypical hereditary cellular or blood trait, genetic information, liability for military service, and mental or physical disability, perceived disability, and AIDS and HIV status, discriminate against any person who is qualified and available to perform the Work to which the employment relates;
- (b) Neither the Contractor, its Subcontractors, nor any person acting on behalf of the Contractor or any of its Subcontractors shall, in any manner, discriminate against or intimidate any employee engaged in the performance of Work under the Contract or any subcontract hereunder, or engaged in the procurement, manufacture, assembling or furnishing of any

such materials, equipment, supplies or services to be acquired under such contract, on account of race, creed, religion, color, national origin, nationality, ancestry, age, sex (including pregnancy), familial status, marital status, domestic partnership or civil union status, affectional or sexual orientation, gender identity or expression, atypical hereditary cellular or blood trait, genetic information, liability for military service, and mental or physical disability, perceived disability, and AIDS and HIV status;

- (c) There may be deducted from the amount payable to the Contractor by the College, under the Contract, a penalty of \$50.00 for each person for each calendar day during which such person is discriminated against or intimidated in violation of the provisions of the Contract; and
- (d) The Contract may be canceled or terminated by the College, and all money due or to become due hereunder may be forfeited, for any violation of this Article of the Contract occurring after notice to the Contractor from the College of any prior violation of this Article of the Contract. The Contractor and its Subcontractors shall comply with all laws prohibiting discrimination against employees, and shall comply with the provision in the Contract regarding employment discrimination.

If the State's Law Against Discrimination is amended, or the language stated herein is inconsistent with the language contained in the State's Law Against Discrimination, the language of the State's Law Against Discrimination shall control.

18.3 Patents.

If any design, device, material or process covered by patents or copyright is used in the Work, the Contractor shall provide for such use by a suitable agreement with the patent or copyright owner. The Contractor shall bear all costs arising from the use of patented materials, equipment, or processes and all copyrighted materials used on or incorporated in the Work. The Contractor shall defend, indemnify and hold harmless the College and its representatives from any and all claims for infringement by reason of the use of any such patented or copyrighted items.

18.4 The Contractor's Compliance With Law.

The Contractor shall keep fully informed of all federal, state and local laws, ordinances, regulations and orders of agencies that have jurisdiction or authority that in any manner affect those employed on the Project or the Project. The Contractor shall at all times observe and comply with, and cause its agents and employees to observe and comply with, all such laws, ordinances, regulations, and/or orders. The Contractor shall also protect and indemnify, defend and hold harmless the College and its representatives against any claim or liability arising from the violation of any laws, ordinances, regulations, or orders, whether by the Contractor or its employees, agents, Subcontractors at any tier, suppliers or materialmen.

18.5 Environmental Protection – The Contractor’s Duty To Comply With Applicable Law.

The Contractor shall comply with all applicable federal, state and local laws and regulations and all conditions of permits pertaining to the protection of the environment. Necessary precautions shall be taken to prevent pollution of streams, lakes, ponds, rivers, wetlands, groundwater, reservoirs, and property by chemicals, fuels, oils, bitumens, or other harmful or hazardous materials as defined by law. The Contractor also shall not pollute the atmosphere from particulate or gaseous matter in violation of applicable law.

18.6 No Personal Liability Of College Officials.

In carrying out any of the provisions of the Contract, or in exercising any right or authority granted to them by or in connection with the Contract, there shall be no liability upon any trustee, officer or employee of the College, either personally or as officials of the College, it being agreed that in all such functions they act only as agents and representatives of the College.

18.7 Recovery Of Monies By The College From Other Contracts With The Contractor.

When the Contract Documents authorize the College to withhold or deduct money from any monies due to the Contractor, or require the Contractor to pay or return monies for any reason, the College may in its discretion withhold any monies due the Contractor under any other contracts between the Contractor and the College. This right shall not affect the rights of the College against the Contractor or its surety under the Contract, and the College shall not be obliged to exercise this right as to any other contract as a condition of exercising its rights against the Contractor or surety under the Contract.

18.8 Buy American Requirement.

The Contractor shall comply with N.J.S.A. 52:32-1 and N.J.S.A. 52:33-1 et seq., which prohibit the use by the Contractor or Subcontractors of materials or farm products produced and manufactured outside of the United States on any public Work. Notwithstanding any inconsistent provision of any law, and unless the head of the department, or other public officer charged with the duty by law, shall determine it to be inconsistent with the public interest, or the cost to be unreasonable, only domestic materials shall be acquired or used for any public work. This Article shall not apply with respect to domestic materials to be used for any public work, if domestic materials of the class or kind to be used are not mined, produced or manufactured, as the case may be, in the United States in commercial quantities and of a satisfactory quality. If the State’s “Buy American” laws are amended, or the language stated herein is inconsistent with the language contained in the State’s “Buy American” laws, the language of the State’s “Buy American” laws shall control.

18.9 Compliance With Grant Requirements. The Contractor acknowledges and agrees that if the College receives any grant monies in connection with the Project, the Contractor and its Subcontractors shall comply with all requirements associated with such grant or set forth in such grant agreement.

18.10 Modification Of Contract.

No modification or amendment of the Contract shall be effective unless it is in writing and signed by both the College and the Contractor.

18.11 State Sales Tax Exemption.

Materials, supplies or services for exclusive use in constructing the Project are exempt from the State Sales Tax Act. Rentals of equipment are not exempt from any tax under the State Sales Tax Act.

18.12 Successors and Assigns.

The College and the Contractor respectively bind themselves, their successors and assigns, to the other party hereto and to the successors and assigns of such other party in respect to covenants, agreements and obligations contained in the Contract Documents.

The Contractor shall not assign the Contract, nor shall the Contractor transfer or assign any Contract funds, due or to become due, or claims of any nature it has against the College without the prior written approval of the College. The College in its sole discretion and considering primarily the interests of the College may elect either to grant or to deny such approval. If the Contractor attempts to make such an assignment without the College's prior written approval, the Contractor shall nevertheless remain legally responsible for all obligations under the Contract.

The College shall be entitled to assign its rights hereunder to one or more lenders as collateral for loans which the College may obtain to finance construction of the Project and to a party who presently has or later acquires a legal interest in the premises. The Contractor agrees to execute such certificates, documents and instruments as are reasonably requested by the College, including, without limitation, certificates, documents and instruments that evidence the Contractor's consent to an assignment of the Contract or confirm the absence or existence of a default on the part of the College hereunder.

18.13 Construction Liens.

If any Subcontractor or other person working under the Contractor files a construction lien or claim or notice of intention or right to file a lien for or on account of Work, labor, services, materials, equipment or other items furnished under or in connection with the Contract for which the College has paid the Contractor, the Contractor agrees to discharge or remove such lien, claim or notice at its own expense by bond, payment or otherwise within twenty (20) calendar days from the date of the filing thereof, and upon its failure to do so, the College shall have the right to cause any such lien or claim, notice of intention or stop notice to be removed or discharged by whatever means the College chooses, at the sole cost and expense of the

Contractor (such costs and expenses to include legal fees and disbursements). The Contractor agrees to indemnify, defend and hold harmless the College and its representatives from and against any and all such liens, claims or other filings, and actions brought or judgments rendered thereon, and from and against any and all losses, damages, liabilities, costs and expenses, including legal fees and disbursements, which the College may sustain in connection therewith. Further, if any Subcontractor or other person working under the Contractor files a construction lien or claim or notice of intention or right to file a lien for or on account of Work, labor, services, materials, equipment or other items furnished under or in connection with the Contract for which the College has paid the Contractor, the College may, in the College's sole discretion, pay all wages, damages, recoveries, costs and expenses and reasonable counsel fees arising therefrom and deduct the same from any monies due or to become due to the Contractor.

18.14 Independent Contractor Status.

The relationship of the Contractor to the College is that of an independent contractor. The Contractor agrees that it shall conduct itself consistent with such status, and shall not hold itself out as or claim to be a trustee, officer, employee or agent of the College. The Contractor shall not make any claim or demand for any right or privilege applicable to officers or employees of the College, including but not limited to, workers compensation, unemployment insurance benefits, social security coverage, or retirement benefits.

18.15 Third Party Beneficiary Rights Not Intended.

It is specifically agreed between the College and the Contractor that no provisions of the Contract Documents are intended to make the public or any member thereof a third party beneficiary of the Contract, or to authorize anyone not a party to the Contract to maintain a suit for personal injuries, property damage or other claims under the Contract. It is also the intent of the College and the Contractor that no individual or firm that supplies materials, labor, services, or equipment to the Contractor for the performance of the Work shall be a third party beneficiary of the Contract.

18.16 Gifts To College Employees And Agents Prohibited.

The Contractor shall not give any gifts of any nature, nor any gratuity in any form, nor loan any money or anything of value to any College employee or relative thereof, or any agent of the College. The Contractor shall not rent or purchase any equipment or supplies of any kind from any College employee or relative thereof or any agent of the College.

18.17 Compliance With Procurement Statutes.

The Contractor warrants and represents that the Contract has not been solicited or secured, directly or indirectly, in a manner contrary to the law of New Jersey, and in particular the provisions of N.J.S.A. 18A:64-6.1, 6.2 and 6.3, and that the Contractor has not and shall not violate the law of New Jersey relating to the procurement of or the performance of the Contract by any conduct, including the paying of any gratuity of any kind, directly or indirectly, to any College trustee, employee or officer. Any violation of this Article shall be cause for the College to terminate the Contract, to retain all unpaid and/or unearned monies, and to recover all monies paid. The Contractor shall notify the College in writing of any interest which any trustee, officer,

employee or consultant of the College has in, or association with the Contractor, any other contractor, any Subcontractor, material supplier, consultant, or manufacturer, or other party which has any interest in the Project.

18.18 Conflict Of Interest.

The Contractor shall not pay, offer to pay, or agree to pay, either directly or indirectly, any fee, commission, compensation, gift, gratuity, or other thing of value of any kind to any State officer or employee or special State officer or employee, as defined by N.J.S.A. 52:13D-13b. and e., in the Department of the Treasury or any other agency with which the Contractor transacts or offers or proposes to transact business, or to any member of the immediate family, as defined by N.J.S.A. 52:13D-13i., of any such officer or employee, or any partnership, firm, or corporation with which they are employed or associated, or in which such officer or employee has an interest within the meaning of N.J.S.A. 52:13D-13g.

The solicitation of any fee, commission, compensation, gift, gratuity or other thing of value by any State officer or employee or special State officer or employee from any State vendor shall be reported in writing forthwith by the Contractor to the Attorney General and the Executive Commission on Ethical Standards.

The Contractor may not, directly or indirectly, undertake any private business, commercial or entrepreneurial relationship with, whether or not pursuant to employment, contract or other agreement, express or implied, or sell any interest in the Contractor to, any State officer or employee or special State officer or employee having any duties or responsibilities in connection with the purchase, acquisition or sale of any property or services by or to any State agency or any instrumentality thereof, or with any person, firm or entity with which he is employed or associated or in which he has an interest within the meaning of N.J.S.A. 52:13D-13g. Any relationships subject to this Article shall be reported in writing forthwith to the Executive Commission on Ethical Standards, which may grant a waiver of this restriction upon application of the State officer or employee or special State officer or employee upon a finding that the present or proposed relationship does not present the potential, actuality or appearance of a conflict of interest.

The Contractor shall not influence, or attempt to influence or cause to be influenced, any State officer or employee or special State officer or employee in his official capacity in any manner which might tend to impair the objectivity or independence of judgment of said officer or employee.

The Contractor shall not cause or influence, or attempt to cause or influence, any State officer or employee or special State officer or employee to use, or attempt to use, his official position to secure unwarranted privileges or advantages for the Contractor or any other person.

The provisions cited above shall not be construed to prohibit a State officer or employee or special State officer or employee from receiving gifts from or contracting with the Contractor under the same terms and conditions as are offered or made available to members of the general public subject to any guidelines the Executive Commission on Ethical Standards may promulgate.

The Contractor shall require its Subcontractors and suppliers to comply with the requirements of this Article.

18.19 Confidential Information.

The Contractor shall maintain the confidentiality of information specifically designated as confidential by the College, unless withholding such information would violate applicable law. The Contractor shall require its Subcontractors to maintain the confidentiality of information specifically designated as confidential by the College.

18.20 Publicity.

Publicity and/or public announcements pertaining to the Project must be approved in writing by the College prior to release.

PROJECT SPECIFICATIONS

For

**FIELD HOCKEY/LACROSSE FIELD
E-LAYER REPLACEMENT**

OUR FILE No.: SCE-R09899.021

TOWNSHIP OF EWING, COUNTY OF MERCER, STATE OF NEW JERSEY

THE COLLEGE OF NEW JERSEY

**ISSUED FOR BID
AUGUST 2020**

08-03-2020

**DAREN J. PHIL, PE
NJPE LICENSE #24GE03619100**

Date

SUBURBAN CONSULTING ENGINEERS, INC.

96 U.S. Highway 206, Suite 101, Flanders, New Jersey 07836
973-398-1776; Fax 973-398-2121

Field Hockey/Lacrosse E-Layer Replacement Project

PROPOSAL

We, _____, the Undersigned, in accordance with the bid documents inviting proposals, will furnish all labor, material, equipment and services necessary for the complete construction, as defined in the bid documents, specimen contract, specifications, general conditions, addendums/clarifications/bulletins, drawings, and proposal, for the Contract amount indicated below for the above noted project in strict accordance with the Contract Documents and Addenda thereto for the total sum of:

Total Lump Sum Price \$ _____
(In Figures)

_____ DOLLARS

_____ Total Lump Sum Price Written in Words

Submitted on _____, 20_____

UNIT PRICES

Please provide the unit price used in your bid tabulation for the item listed below for reference in case a portion of the pipe can remain in place.

| <u>Item</u> | <u>Description</u> | <u>Proposal Quantity</u> | <u>Unit</u> | <u>Unit Price Bid</u> | <u>Amount</u> |
|-------------|---|------------------------------|-------------|---------------------------|---------------|
| 1. | Replace Existing 8" Perimeter Pipe (If and Where Directed) | 50 | LF | \$_____. | \$_____. |

Division 1 TCNJ Specifications

| | | |
|---------|--------|------------------------------|
| Section | 01010 | Summary of Work |
| Section | 01025 | Measurement and Payment |
| Section | 01100 | Project Procedures |
| Section | 01300 | Submittals and Substitutions |
| Section | 01310 | Quality Control |
| Section | 01320 | Temporary Facilities |
| Section | 01322 | Photographic Documentation |
| Section | 01330 | Contract Closeout |
| Section | 01340 | Project Record Documents |
| Section | 01524 | Construction Waste |
| Section | 017836 | Warranties |

Division 31 Technical Specifications

| | | |
|---------|--------|-----------------------------------|
| Section | 311000 | Site Clearing |
| Section | 312000 | Earth Moving |
| Section | 315000 | Excavation Support and Protection |

Division 32 Technical Specifications

| | | |
|---------|--------|----------------------|
| Section | 321823 | Elastic Layer System |
|---------|--------|----------------------|

Division 33 Technical Specifications

| | | |
|---------|-----------|-------------------------------|
| Section | 330130.11 | Television Inspection of Pipe |
| Section | 334100 | Storm Utility Drainage Piping |

SECTION 01010 - SUMMARY OF WORK

PART 1 - GENERAL

1.1 RELATED DOCUMENTS

- A. Drawings and general provisions of the specifications, including General and Supplementary Conditions and other Division 1 Specification Sections, apply to this Section.

1.2 WORK COVERED BY CONTRACT DOCUMENTS

- A. The Project consists of all work noted on the drawings and in these specifications.
 - 1. Project Location: The College of New Jersey, Ewing, New Jersey
 - 2. Owner: The College of New Jersey, State of New Jersey
- B. SCOPE OF WORK SUMMARY:
 - 1. Removal and disposal of the existing e-layer, finish stone, base stone, filter fabric and flat panel piping.
 - 2. Existing 8" perimeter pipe to be inspected to determine its condition.
 - 3. Based on the 8" perimeter pipe inspection, replace all lengths of the pipe with new 8" HDPE perforated pipe as required.
 - 4. Installation of finish stone, base stone, panel piping, filter fabric and e-layer in accordance with the plans.
 - 5. After installation of the base and finish stone, contractor to have a third party perform infiltration testing to determine the porosity. The Contractor is to submit an infiltration report to the College and College's Engineer for approval prior to the installation of the e-layer. The Contractor will have a third party perform additional infiltration testing after the installation of the e-layer to determine the porosity. The College and College's Engineer are to review the infiltration report for approval.
 - 6. Coordination with the College, College's Engineer, and Turf Contractor to ensure the e-layer and stone base have met the FIH standards and that the Turf Contractor will accept the e-layer for installation of their turf.
 - 7. Provide site restoration and cleanup as required.
 - 8. Provide all required permits and fees for construction.

1.3 CONTRACTS

- A. The project contract is between The College of New Jersey and the single prime contractor performing the work specified.
- B. Definition of Extent of Contract Work: The contract documents, specifications, project drawings, manufacturer's installation handbooks, TCNJ form of agreement, and the contractor's response to the RFP represent the extent of the construction contract.

1.4 CONTRACTORS USE OF PREMISES

- A. General: During the construction period, the Contractor shall have full use of the premises for construction operations, including use of the site. The Contractor's use of the premises is limited only

by the Owner's rights to perform work, retain other Contractors on portions of associated projects, or to access the building for the occupants.

1. Contractor is to coordinate their work with the activities for each work location.
- B. Use of the Site: Limit use of the premises to areas required for equipment and material storage and access to the project site. Confine operations to areas within contract limits indicated. Do not disturb portions of the site beyond the areas immediately adjacent to the field where the work is being performed.
1. Owner Occupancy: Allow for Owner occupancy.
 2. Driveways and Entrances: Keep driveways and entrances serving the premises clear and available to the Owner, the Owner's employees, and emergency vehicles at all times. Do not use these areas for parking or storage of materials unless previously approved by the Owner. Schedule deliveries to minimize space and time requirements or storage of materials and equipment on-site.
 3. Burial of Waste Materials: Disposal of organic and hazardous materials on-site either by burial or burning, will not be permitted.
 4. Parking is allowed within the construction fence only. If more parking is needed, there is additional parking provided at the college's Carlton Avenue parking lot. The contractor is responsible to shuttle workers back and forth as needed.
- C. Maintain any existing building at the project site in a weathertight condition throughout the construction period. Repair damage caused by construction operations. Take all precautions necessary to protect the building, its contents, components, and systems and its occupants during the construction period.

PART 2 - PRODUCTS (NOT USED)

PART 3 - EXECUTION (NOT USED)

END OF SECTION

SECTION 01025 – MEASUREMENT AND PAYMENT

PART 1 - GENERAL

1.1 SCHEDULE OF VALUES

- A. Each Contractor shall prepare a schedule of values in coordination with preparation of the progress schedule. Correlate line items with other administrative schedules and forms required for the work, including progress schedule, payment request form, listing of subcontractors, schedule of allowances if any, schedule of alternates if any, listing of products and principal suppliers and fabricators, and schedule of submittals. Break down principal subcontract amounts into multiple line items for each entity of work. Round off to nearest whole dollar, but with total equal to Contract Sum. Submit four (4) copies of schedule of values to the Owner and Architect/Engineer for review and approval.
 1. Upon Owner/Architect/Engineer approval, Owner will return the Schedule of Values to the Contractor for the Contractor to submit to the bonding company for their acceptance. Payments will not be made to the Contractor until the bonding company has provided a written acceptance to the Owner.
- B. The schedule of values shall be tabulated into subcontracts and trades with the Quantity, Labor, Material, and Total Cost indicated. The Schedule of Values shall include such items as bonds, insurance, allowances and alternates, punch list/close out documents and shall enclose copies of invoices and/or cancelled checks from bonding and insurance agents.
- C. Schedule of values shall be submitted on AIA Form G703 or similar form approved by the Architect/Engineer and Owner.
- D. Each Contractor's monthly application for payment shall be in the same schedule form, reflecting the same items from above. Unit costs shall be realistic for their part of the Work.

1.2 CHANGES IN THE WORK

- A. When a change in the Work includes a category or categories of Work both added to and deducted from the Contract, the total quantities of added Work and of deleted Work shall be determined separately for each category and the appropriate unit price or net cost of the Work shall be applied to the difference between the two total quantities.
- B. Unit prices shall be inclusive of all costs and shall be applied to units of measure as defined in the Specifications for each category of Work.
- C. For all extra Work performed by the Contractor, the gross cost to the Owner shall include the net cost of the Work to the Contractor plus an allowance for overhead and profit not to exceed fifteen percent (15%) of the net cost.
- D. For all extra Work performed by a Subcontractor, the gross cost to the Owner shall include the net cost of the Work to the Subcontractor plus an allowance for overhead and profit not to exceed fifteen percent (15%) of the net cost, plus the Prime Contractor's overhead and profit not to exceed five percent (5%) of the Subcontractor's cost.

- E. Net cost of extra Work shall be the actual or pro-rated cost of:
 - 1. Labor, including foreman, at the prevailing rate of wages, contributions and taxes.
 - 2. Materials entering permanently into the Work, including delivery to the site.
 - 3. The ownership or rental cost of construction equipment and expendable tools, pro-rated for the time necessary for the Work.
 - 4. Power and consumable supplies for the operation of power equipment, pro-rated for the time necessary for the Work.
 - 5. Insurance and Bonds.
- F. Gross costs shall be net costs plus the mark-up allowances described above, such mark-up allowances being inclusive, of all cost of superintendence, supervision, engineering, overhead, profit, administrative and site office expenses and all other general expenses.

1.3 APPLICATIONS FOR PAYMENT

- A. Except as otherwise indicated, sequence of progress payments for the Contractor shall be regular, and each shall be consistent with previous applications and payments. It is recognized that certain applications involve extra requirements, including initial applications, applications at times of substantial completion, and final payment applications.
- B. Payment Application Forms: Use AIA Document G702 and G703 Continuation Sheets; available from Publications Distribution Div., The American Institute of Architects, 1735 New York Ave., N.W., Washington, D.C. 20006 (also available at most local AIA chapter offices).
- C. Except as otherwise indicated, complete every entry provided on the form, including notarization and execution by authorized persons. Incomplete applications will be returned by Architect/Engineer and Owner without action. Entries shall match current data of schedule of values, progress schedules and reports. Listing shall include amounts of fully executed change orders issued prior to first day of the period of construction covered by application. Applications for payment shall include weekly payroll report. Contractor shall furnish to the Owner certified payroll reports for each payroll period with pay request, indicating name craft, social security number and actual hourly rate of wages paid to each workman employed on the project. A certified payroll record is defined as "a payroll record which is attested to by the employer, or corporate officer of such company, or an authorized agent of the employer." A payment request will not be paid until the Owner receives the certified payrolls.
- D. Submit one "pencil" copy of each proposed payment application to the architect and owner, for review, not less than seven (7) days prior to formal submissions of application.
- E. Submit four (4) executed copies of each payment application. Transmit with a transmittal form listing attachments, and recording appropriate information related to application.
- F. Breakdown may include a line item for General Conditions. General Conditions shall include the cost of general supervision, trailers, temporary utilities and other general expenses directly related to the project and not considered overhead. The general conditions item shall be billed on monthly progress payments on a percentage of work completed.

1.4 INITIAL PAYMENT APPLICATION

- A. The principal administrative actions and submittals which shall precede or coincide with submittal of the Contractor's first payment application can be summarized as follows, but not necessarily by way of limitation.
1. Listing of subcontractors and principal suppliers and fabricators.
 2. Schedule of values.
 3. Schedule of principal products.
 4. Schedule of submittals (preliminary if not final).
 5. Copies of acquired building permits and similar authorizations and licenses from governing authorities for current performance of the work.
 6. Data needed by Owner to secure related insurance coverages.
 7. Performance and Payment Bond.
 8. Insurance Certificates.

1.5 PROGRESS PAYMENTS

- A. Based upon application for payments submitted to the Architect/Engineer and the Owner, by the Contractor, on or about the 25th day of each month for the period ending the last day of the previous second month, and Certificate of Payment issued by the Engineer and the Owner, the Owner will make progress payments on account of the Contract Sum to the Contractor as follows:
1. On or after the 20th day of each month, the Contractor shall submit to the Architect and Owner a "pencil copy" indicating the previous payment and the proposed amounts for each line item for the current period. After review and approval or changes, the Contractor shall prepare the final billing for presentation to the Architect/Engineer and Owner.
 2. Whenever any contract, the total price of which exceeds \$100,000, entered into by a State college, for the construction, reconstruction, alteration or repair of any building, structure, facility or other improvement to real property, requires the withholding of payment of a percentage of the amount of the contract, the contractor may agree to the withholding of payments in the manner prescribed in the contract, or may deposit with the State college registered book bonds, entry municipal bonds, State bonds or other appropriate bonds of the State of New Jersey, or negotiable bearer bonds or notes of any political subdivision of the State, the value of which is equal to the amount necessary to satisfy the amount that otherwise would be withheld pursuant to the terms of the contract. The nature and amount of the bonds or notes to be deposited shall be subject to approval by the State college. For purposes of this section, "value" shall mean par value or current market value, whichever is lower.
 - a. If the contractor agrees to the withholding of payments, the amount withheld shall be deposited, with a banking institution or savings and loan association insured by an agency of the Federal government, in an account bearing interest at the rate currently paid by such institutions or associations on time or savings deposits. The amount withheld, or the bonds or notes deposited, and any interest accruing on such bonds or notes, shall be returned to the contractor upon fulfillment of the terms of the contract relating to such withholding. Any interest accruing on cash payments withheld shall be credited to the State college.
 - b. Any contract, the total price of which exceeds \$100,000, entered into by a State college involving the construction, reconstruction, alteration, repair or maintenance of any building, structure, facility or other improvement to real property, shall provide for partial payments to be made at least once each month as the work progresses, unless the contractor shall agree to deposit bonds with the State college pursuant to section 1.
 - c. With respect to any contract entered into by a State college pursuant to section 2 for which the contractor shall agree to the withholding of payments pursuant to section 1, two percent

(2%) of the amount due on each partial payment shall be withheld by the State college pending completion of the contract.

- d. Upon acceptance of the work performed pursuant to the contract for which the contractor has agreed to the withholding of payments pursuant to subsection a. of this section, all amounts being withheld by the State college shall be released and paid in full to the contractor within 45 days of the final acceptance date agreed upon by the contractor and the State college, without further withholding of any amounts for any purpose whatsoever, provided that the contract has been completed as indicated. If the State college requires maintenance security after acceptance of the work performed pursuant to the contract, such security shall be obtained in the form of a maintenance bond. The maintenance bond shall be no longer than two years and shall be no more than 100% of the project costs.
 - e. This act shall take effect immediately. This bill supplements the "State College Contracts Law," P.L.1986, c.43 (C.18A:64-52 et seq.), and applies to any State college contract for over \$100,000 which involves the construction, reconstruction, alteration or repair of any building, structure, facility or other improvement to real property. Under the provisions of this bill, whenever a contract of this type requires the withholding of payment of a percentage of the amount of the contract, the contractor would have the choice of either agreeing to a retainage deduction from each monthly progress payment, or the contractor could choose to deposit bonds in the amount necessary to satisfy the amount that otherwise would be withheld under the contract. If a contractor chooses a retainage deduction from each monthly payment, then the retainage would be limited to two percent (2%) of the amount due on each partial payment. Upon acceptance of the work performed pursuant to the contract for which the contractor has agreed to a retainage deduction, all amounts being withheld by the State college must be paid in full to the contractor within 45 days of the final acceptance date agreed upon by the contractor and the State college. The bill provides that if the State college requires maintenance security after acceptance of the work performed under the contract, the security must be obtained in the form of a maintenance bond, which is required to be no longer than two years and no more than 100% of the project costs. The provisions of this bill are similar to provisions in the "Local Public Contracts Law," P.L.1971, c.198 (C.40A:11-1 et seq.) and the "Public School Contracts Law," P.L.1977, c.114 (C.18A:18A-1 47 et seq.).
3. Upon substantial completion, the retainage shall, upon the Architect/Engineer/Owner's approval, remain at two percent (2%) of the value of work completed. Final release of retained monies will occur only upon the total completion of all punch list and closeout documentation to the satisfaction of the Architect/Engineer and Owner.
 4. For each day's delay in the Contractor's submission of an application for payment acceptable to the Architect/Engineer and Owner, the Owner may delay one day in making his progress payment.
 5. Owner shall make payments within 30 days of receipt of said monthly pay requisition.

1.6 APPLICATION AT TIME OF SUBSTANTIAL COMPLETION

- A. Following issuance of certificate of substantial completion on each Contractor's work, and also in part as applicable to prior certificates on portions of completed work as designated, a "special" payment application may be prepared and submitted by Contractor. The principal administrative actions and submittals which shall precede or coincide with such special applications can be summarized as follows, but not necessarily by way of limitation:
 1. Occupancy permits and similar approvals or certifications by governing authorities and franchised services, assuring Owner's full access and use of completed work.
 2. Warranties, guarantees, maintenance agreements and similar provisions of Contract Documents.

3. Test/adjust/balance records, maintenance instructions, meter readings, start up performance reports, and similar change over information germane to Owner's occupancy, use, operation and maintenance of completed work.
4. Final cleaning of the work.
5. Application for reduction (if any) of retainage, with consent of surety.
6. Advice to Owner on coordination of shifting insurance coverages, including proof of extended coverage as required.
7. Listing of Contractor's incomplete work, recognized as exceptions to certificate of substantial completion.

1.7 FINAL PAYMENT APPLICATION

- A. The administrative actions and submittals which shall precede or coincide with submittal of the Contractor's final payment application can be summarized as follows, but not necessarily by way of limitation.
1. Completion of project closeout requirements.
 2. Completion of items specified for completion beyond time of substantial completion, regardless of whether special payment application was previously made.
 3. Assurance, satisfactory to Owner, that unsettled claims will be settled and that work not actually completed and accepted will be completed without undue delay.
 4. Transmittal of required project construction records to Owner.
 5. Proof, satisfactory to Owner, that taxes, fees and similar obligations of Contractor have been paid.
 6. Removal of temporary facilities, services, surplus materials, rubbish and similar elements.
 7. Notarized consent of surety for final payment.

1.8 WAIVER OF LIENS

- A. Each Contractor, for himself, and for all Subcontractors and material men, agrees that no mechanic's lien or other claim shall be filed or maintained by the Contractor or by any Subcontractor, materialmen, laborer or any other person whatsoever for, or on account of any work performed or materials furnished under this Contract. This agreement shall be an independent contract, and the Contractor shall execute and deliver a separate Waiver of Liens in form and substance satisfactory to the Architect and Owner contemporaneously with the execution of the Owner-Contractor Agreement and before any work is begun at the site.
- B. In every subcontract entered into by each Contractor after execution of this Contract or in connection herewith, the Contractor shall incorporate a provision, similar to the foregoing paragraph, to the effect that neither the Subcontractor nor any party acting through or under him shall file or maintain any mechanic's lien or other claim against the Architect/Engineer or Owner in connection with the Work.

PART 2 - PRODUCTS (NOT USED)

PART 3 - EXECUTION (NOT USED)

END OF SECTION

SECTION 01100 - PROJECT PROCEDURES

PART 1 - GENERAL

1.1 SPECIAL REQUIREMENTS

- A. **Schedule:** Contractor shall provide a master schedule showing sequencing of work utilizing the CPM method. The Contractor shall supply a schedule with all subcontractor activities, relationships, and durations, utilizing the CPM method via SureTrak/Primavera, Version 3.0, or a Microsoft scheduling software to the Owner on a working version CD rom and coordinate their schedule with the Owner.
1. The Contractor is required to update, at the end of each month, the CPM Schedule based on the percentage completed for each activity on the approved schedule (in concert with the submission of the percentage completed in the monthly proposed schedule of values).
 2. **The contractor in their bid includes a cost of \$500.00 per month for this schedule submission, for the duration of construction (per the milestone schedule in the bidding documents). This only applies to projects in excess of 2 million dollars in base cost. The contractor's schedule of values shall include this cost, and can only be billed for upon TCNJ's successful receipt of said schedule. Should any schedule not be received at the end of any month during construction, TCNJ will issue a deduct change order in the amount of \$500.00 to the contractor.**
- B. Each Contractor shall take all necessary precautions to ensure the safety of all structural elements during all phases of all work. No materials, cranes, trucks or any other construction loads shall be placed on any part of the structure until the Contractor has determined the adequacy of that structure to carry the intended load without damage or overstress.
- C. Entrance into, or other use of any building will not be permitted except as may be necessary for the execution of the Work and shall be subject to the restrictions and instructions of the Owner.
1. **NOTE: Any personnel working in any residence hall, including delivery personnel are to have a State Police Background check completed before entering any residence hall. Contractor is to provide the background check for all personnel at the kick off meeting, and/or prior to start of their work. Should a person not have a background check but is on site for a short period of time, said person shall be escorted by a TCNJ project manager/superintendent and /or a designated person that has provided the appropriate back ground check information. All background checks will be forwarded to TCNJ police for review and filing.**
 2. **NOTE: Any personnel working in a residence hall must wear a badge with the name of the vendor/contractor they work for and their personal name. This badge must be worn at all times.**
- D. Routes of ingress and egress to areas where work is being performed shall be subject to the restrictions and instructions of the Owner.
- E. Materials shall be moved through the site using rubber-tired vehicles which shall be properly controlled at all times to avoid damage to existing surfaces.
- F. Water damage cannot be tolerated and it is incumbent upon Contractors to take any steps necessary to keep the existing premises dry at all times.

- G. Any damage from heavy equipment to any part of the premises shall be repaired at the expense of the Contractors.
- H. All welding and cutting shall be performed by qualified and certified welders. Certificates shall be on file with the Contractor prior to commencement of any welding.
- I. No work shall start before 7:30 AM unless agreed to in advance with the College.

PART 2 - PRODUCTS (NOT USED)

PART 3 - EXECUTION

3.1 GENERAL

- A. Contractors shall perform the work on or about the premises in a careful manner with full consideration to fire protection as required by the National Fire Protection Association Standards, National Board of Fire Underwriters and State and Local Departments having jurisdiction. Fire resistant materials shall be used for temporary enclosures.
- B. Chemical extinguishers approved by the Owner shall be provided by the General Contractor during the progress of the work where and as required by the Owner, the Local Fire Marshal and the National Board of Fire Underwriters.
- C. The Contractor shall maintain an active program of fire prevention to keep workmen fire conscious during the entire life of the Contract. Designate one member of the organization to execute and coordinate fire control measures of his own organization and that of all subcontractors under his jurisdiction.
- D. All sub-contractors shall cooperate with the Contractor in carrying out the above program.
- E. Storage of flammable materials will not be permitted in any Building unless written permission is obtained from the Owner. Storage of all such materials shall be the Contractors' responsibility.
- F. On-site open burning of rubbish, garbage, trade waste, leaves or plant life is prohibited.
- G. Safety Program: The Contractor shall institute a safety program in accordance with OSHA and any local, state, or federal guidelines. The contractor shall name a safety officer to monitor this program and shall submit a safety report at job meetings.
- H. Stockpiling: Stockpiling of materials on site will be allowed (but limited due to the limited space on this site). Such materials shall not impair or impede the functioning of the facility. Materials stored on site shall be secured to prevent loss from theft, damage, vandalism or fire. By stockpiling materials on site, the contractor assumes full responsibility for said materials, and shall protect them to the fullest extent possible. Specific locations for stockpiling materials shall be coordinated with the Architect/Engineer, and Owner.
- I. Safety Barriers: The Contractor shall erect safety barriers to deter and prohibit unauthorized access to the construction site; such barriers may take the form of fences and shall be clearly marked with signage prohibiting unauthorized access. The Contractor shall be responsible for safety barriers within the building. The contractor shall be liable for damages to persons or property due to the construction

process if adequate safety measures are not undertaken. The Owner and Architect/Engineer shall review safety precautions for their adequacy but shall not be held liable for Contractors' failure to maintain or provide adequate protection.

- J. Sequencing: The Contractor will work with the Sub-Contractors to sequence the work during the submission of monthly project schedules. Contractors shall endeavor to coordinate their work efforts with the Owner's requirements. Interruptions of utility services shall be coordinated with the Architect/Engineer and Owner, but in no instance shall last longer than two (2) hours.
- K. Limited staging and on-site parking will be provided by General Contractor. The Contractor will coordinate parking areas with all the subcontractors and TCNJ.
 - 1. Parking will be available at Carlton Avenue. Contractor will provide shuttle service to and from the site.
 - 2. Contractor will be permitted to have vehicles on site within the construction fencing only. Contractor is to provide stone in all parking areas on site to prevent the buildup of ruts and mud, thus minimizing the amount of mud leaving the site and being left behind on TCNJ roads.
- L. Site Utilities: Electric power and water are available on site. Toilet facilities will be made available by the Contractor. These facilities shall remain clean by the Contractors throughout the course of the project. Interruption of building services shall not occur without prior consent and coordination by the Architect/Engineer and Owner.
 - 1. Provide portable toilets for all construction personnel.
- M. Construction Lighting: The Contractor shall provide temporary lighting as needed throughout the project areas.
- N. Dumpster Location and Cleanup: The Architect/Engineer and Owner shall coordinate the dumpster location with the Contractor. The Contractor shall be responsible for obtaining, maintaining, and disposing of dumpsters, and shall maintain clean work areas throughout the course of the project.

Contractor is to provide adequate manpower during the entire course of the project to maintain the site in a clean, neat and professional manner. At a minimum, the contractor is to clean the entire site twice per week (on different days) by picking up all debris in and around the site. Contractor is to place a minimum of three (3) garbage cans at each site in designated locations to assist in keeping the site clean. The owner will not tolerate a project that is not maintained in a professional manner at all times.

3.2 PROGRESS MEETINGS

- A. Progress Meetings shall be held bi-weekly at the job site at a regular time and day mutually agreed upon. The frequency may be changed by the Architect/Engineer or Owner to reflect current conditions. The Contractors, those of his/their Sub-contractors concerned with current progress or with scheduling of future progress, the Architect/Engineer and the Owner shall each be represented at these job meetings by persons familiar with the details of the work and authorized to conclude matters relative to work progress, establishment of progress schedules, etc., as may be necessary to expedite completion of the work.
- B. The Contractors and his/their subcontractors attending these meetings shall present complete and definite reports as to the status of their respective work, conditions of product and equipment manufacturer, labor availability, productivity and cooperation, shipping data, time of completion, sequence of the work, safety program, and any other information bearing upon the execution of the Contract or subcontract. For the Owner's convenience, the Owner will chair the meetings.

3.3 MONTHLY REPORTS

- A. The Contractor is to provide TCNJ a brief monthly status report on the last working day of each month dividing the status of the project into the following categories (report must be complete in all aspects, piece meal submissions will not be accepted):
1. Project overview
 2. Financial status
 3. Updated project schedule
 4. Change order request log
 5. Submittal log
 6. RFI log
 7. Owner/Architect issues that need immediate resolution
 8. Order/delivery issues
- B. The Contractor is to provide TCNJ with this monthly report and include in their bid a cost of \$500.00 per month for all projects in excess of 2 million dollars base bid price for the duration of the construction period as noted in the bidding milestone schedule. This total cost will be listed in the contractor's schedule of values and can be billed for on a monthly basis only if said report is received in whole as noted above. Should TCNJ not receive said complete report, a deduct change order will be issued to the contractor for \$500.00 for that month.

END OF SECTION

SECTION 01300 – SUBMITTALS AND SUBSTITUTIONS

PART 1 - GENERAL

1.1 PROGRESS SCHEDULE / COORDINATION DRAWINGS

- A. The Contractor's schedule shall coordinate with all trades to produce a coordinated CPM via Suretrak/Primavera version 3.0 or a Microsoft scheduling program schedule indicating the start and completion dates for each portion of the work as defined by the schedule of values, with the total time as defined by the contract time and milestone dates as set forth in these specifications. The Contractor's CPM schedule shall be submitted in electronic format (Suretrak 3.0 or a Microsoft Scheduling program) to and reviewed by the Owner and Architect/Engineer prior to first application for payment. Any revisions or additional information requested by the Owner or Architect shall be provided. (No payment shall be made to any Contractor not providing a schedule that reflects their entire work).
1. Also refer to Section 01100 – Project Procedures.
- B. The Contractor shall revise the progress schedule on a monthly basis as the work progresses reflecting therein any delays, including those not within the Contractor's control, or accelerations in the progress of the work. The progress schedule, as revised for any weekly period, shall be discussed at the bi-weekly job meetings with the Owner, the Architect/Engineer and the Contractor and the major trades in order to insure that the percentage of actual completion of any portion of the work as called for in the progress schedule for that bi-weekly period is attained. Monthly updates to the progress schedule shall be made prior to application for payment.
- C. Should any delay occur in the progress of the work or any portion thereof, the Contractor shall be required to implement all necessary measures to accelerate the construction, to meet the percentages of completion dictated by the progress schedule on the applicable dates, without additional cost to the Owner.

1.2 SHOP DRAWINGS, PRODUCT DATA AND SAMPLES

- A. Shop drawings, product data and samples will not be processed by the Owner and/or Architect/Engineer until the list of subcontractors, material suppliers and fabricators is submitted as required under Paragraph 3.12 of the General Conditions.
1. The successful Contractor shall submit their list of proposed substitutions within twenty (20) calendar days of the Contract Award.
2. The Architect/Engineer shall be compensated on an hourly basis for review of all shop drawings or samples that do not meet the requirements of the contract documents after two (2) submissions. The compensation shall be deducted from the contractor's contract via a deduct change order, or other means that both parties agree to.
- B. Coordinate preparation and processing of submittals with performance of the work so that work will not be delayed by submittals. Allow one week for review/approval by the Architect/Engineer for the approval process. Allow additional time if processing must be delayed to permit coordination with subsequent submittals with others. Contractor must provide all submittals within the tie period specified in the project schedule.

- C. Provide permanent marking on each submittal to identify Project, date, Contractor, subcontractor, submittal name, Specification section, drawing reference, and similar information to distinguish it from other submittals. Show Contractor's executed review and approval marking and provide space five inches by seven inches (5"x7") for Architect/Engineer's Action marking and space for Owner's review marking. Package each submittal appropriately for transmittal and handling. Submittals received, which are lacking the above information, will be returned without action. Submittals, which are received from sources other than through Contractor's office, will be returned without action.
- D. Each submission shall be complete, with all options clearly marked and with all components required for the assembly fully described and detailed. Submissions missing important information will be returned unchecked.
- E. Transmittal Form: Submittals shall be accompanied by a transmittal form. Provide Contractor's certification on form, ready for execution, stating that information submitted complies with requirements of contract documents.
 - 1. Transmit all submittals and shop drawings to the Architect or Engineer with a copy of the transmittal to the Owner.
- F. Except as otherwise indicated in individual work sections, comply with requirements specified herein for each indicated category of submittal. Provide and process intermediate submittals, where required between initial and final, similar to initial submittals.
- G. Maintain returned final set of samples at project site, in suitable condition and available for quality control comparisons by Architect/Engineer, and by Owner.
- H. Do not proceed with installation of materials, products or systems until final copy of applicable shop drawings, product data and samples are in possession of Installer.
- I. Provide newly prepared shop drawings, on reproducible sheets, with graphic information at accurate scale, with company name of preparer indicated. Show dimensions and note which are based on field measurement. Identify materials and products in the work shown. Indicate compliance with standards, and special coordination requirements. Do not allow shop drawing copies without appropriate final Action markings by Architect/Engineer to be used in connection with the work.
 - 1. Initial and Intermediate Submittals: One correctable translucent reproducible print and 5 blue line or black line prints; reproducible will be returned.
 - 2. Final Submittal: Six (6) prints, plus three (3) additional prints where required for maintenance manuals; four (4) will be retained and remainder will be returned, one of which shall be marked up and maintained by Contractor as "Record Document".
 - 3. Electronic submittals are acceptable in AutoCad format only. Contractor shall be responsible for printing and distribution of multiple copies as required.
- J. Collect required product data into one submittal for each unit of work or system; and mark each copy to show which choices and options are applicable to the project. Include manufacturer's standard printed recommendations for application and use, compliance with standards, application of labels and seals, notation of field measurements that have been checked, and special coordination requirements. Maintain one set of product data for each submittal at project site, available for reference by Architect/Engineer and others.
- K. Submittals will be accepted from the Contractor only. Submittals received from other entities will be returned without review or action.
 - 1. Submittals received without a transmittal form will be returned without review or action.

2. Transmittal form: Use a form matching the sample form attached to this section. Include the following:
 - a. List of deviations.
 - b. The Contractor's certification signature.
 3. Fill out a separate transmittal form for each submittal; also include the following:
 - a. Other relevant information.
 - b. Request for additional information.
- L. Do not submit product data, or allow its use on the project, until compliance with requirements of Contract Documents has been confirmed by Contractor. Submittal is for information and record unless otherwise indicated. Initial submittal is final submittal unless returned promptly by Architect/Engineer marked with an Action that indicates and observed noncompliance. Submit six (6) copies, plus three (3) additional copies, which will be returned, where required for maintenance manuals.
1. Electronic submittals are acceptable in 8 ½"x11" format only.
- M. Provide three (3) samples identical with final condition of proposed materials or products for the work. Include range samples, not less than three (3) units, where unavoidable variations between units of each set. Provide full set of optional samples where Architect/Engineer's selection is required. Prepare samples to match Architect/Engineer's sample where so indicated. Include information with sample to show generic description, source or products name and manufacturer, limitations, and compliance with standards. Samples are submitted for review and confirmation of color, pattern, texture and kind by Architect/Engineer. Architect/Engineer will not test samples, except as otherwise indicated, for compliance with other requirements, which are therefore the exclusive responsibility of the Contractor.
- N. Upon receipt of a signed copy of the Architect/Engineer's Waiver form, electronic copies of CAD drawings of the Contract Documents will be provided by the Architect/Engineer for Contractor's use in preparing submittals. Copy of Waiver form is attached.
- O. Product Selection Procedures: Procedures for product selection include the following:
1. Product: Where Specification paragraphs or subparagraphs titled "Product" name a single product and manufacturer, provide the named product or an equivalent.
 2. Manufacturer/Source: Where Specification paragraphs or subparagraphs titled "Manufacturer" or "Source" name single manufacturers or sources, provide a product of the manufacturer or source that complies with requirements, or an equivalent.
 3. Products: Where Specification paragraphs or subparagraphs titled "Products" introduce a list of names of both products and manufacturers, provide one of the products listed that complies with requirements, or an equivalent. Comply with provisions of "Product Options and Substitutions," Section 1.4 of these specifications when submitting an equivalent product.
 4. Manufacturers: Where specification paragraphs or subparagraphs titled "Manufacturers" introduce a list of manufacturers' names, provide a product by one of the manufacturers listed, or an equivalent, that complies with requirements. Comply with provisions of "Product Options and Substitutions," Section 1.4 of these specifications when submitting an equivalent product.
 5. Product Options: Where Specification paragraphs or subparagraphs refer to "Product Options and Substitutions," indicate that size, profiles, and dimensional requirements on Drawings are based on a specific product or system; provide the specific product or system or an equivalent product or system by another manufacturer. Comply with provisions of "Product Options and Substitutions," Section 1.4 of these specifications when submitting an equivalent product.
 6. Basis of Design Products: Where Specification paragraphs or subparagraphs titled "Basis-of-Design Products" introduce or refer to a list of manufacturers' names, provide either the specified product or an equivalent. Drawings and Specifications indicate sizes, profiles, dimensions and other characteristics that are based on the product names. Comply with the provisions of "Product

Options and Substitutions," Section 1.4 of these specifications when submitting an equivalent product.

1.3 MISCELLANEOUS SUBMITTALS

- A. Miscellaneous submittals related directly to the work include warranties, maintenance agreements, workmanship bonds, survey data and reports, physical work records, quality testing and certifying reports, copies of industry standards, record drawings, field measurement data, operating and maintenance materials, overrun stock, and similar information, devices and materials applicable to the work and not processed as shop drawings, product data or samples.
- B. Refer to sections for specific general requirements on warranties, product/workmanship bonds, and maintenance agreements. In addition to copies desired for Contractor's use, furnish two (2) executed copies, except furnish three (3) additional copies where required for maintenance manuals.
- C. For the Owner's records, submit copies of permits, licenses, certifications, inspection reports, releases, jurisdictional settlements, notices, receipts for fee payments, judgments, and similar documents, correspondence and records established in conjunction with compliance with standards and regulations bearing upon performance of the work.

1.4 PRODUCT OPTIONS AND SUBSTITUTIONS

A. DEFINITIONS

- 1. Products: Items purchased for incorporating into the Work, whether purchased for Project or taken from previously purchased stock. The term "product" includes the terms "material," "equipment," "system," and terms of similar intent.
 - a. Named Products: Items identified by manufacturer's product name, including make or model number or other designation, shown or listed in manufacturer's published product literature, that is current as of date of the Contract Documents.
 - b. New Products: Items that have not previously been incorporated into another project or facility, except that products consisting of recycled-content materials are allowed, unless explicitly stated otherwise. Products salvaged or recycled from other projects are not considered new products.
 - c. Equivalent Product: Product that is demonstrated and approved through submittal process, or where indicated as a product substitution, to have the indicated qualities related to type, function, dimension, in-service performance, physical properties, appearance, and other characteristics that equal or exceed those of specified product.
- 2. Substitutions: Changes in products, materials, equipment, and methods of construction from those required by the Contract Documents and proposed by Contractor.
- 3. Basis-of-Design Product Specification: Where a specific manufacturer's product is named and accompanied by the words "basis of design," including make or model number or other designation, to establish the significant qualities related to type, function, dimension, in-service performance, physical properties, appearance, and other characteristics for purposes of evaluating comparable products of other named manufacturers.
- 4. Manufacturer's Warranty: Preprinted written warranty published by individual manufacturer for a particular product and specifically endorsed by manufacturer to Owner.
- 5. Special Warranty: Written warranty required by or incorporated into the Contract Documents, either to extend time limit provided by manufacturer's warranty or to provide more rights for Owner.
- 6. Buy American Requirement: The Contractor shall comply with N.J.S.A 52:32-1 and N.J.S.A.

52:33-1 et seq., which prohibits the use by the Contractor or subcontractors of materials or farm products produced and manufactured outside of the United States on any public work.

B. General Requirements:

1. The requirements for substitutions do not apply to specified Contractor options on products and construction methods. Revisions to Contract Documents, where requested by Owner or Architect/Engineer are changes, not substitutions. Contractor's determination of and compliance with governing regulations and orders issued by governing authorities do not constitute substitutions and do not constitute a basis for change orders. Otherwise, Contractor's requests for changes in products, materials, and methods of construction required by Contract Documents are considered requests for substitutions and are subject to requirements hereto.
2. To the greatest extent possible, provide products, materials and equipment of a singular generic kind and from a single source.
3. Where more than one choice is available as options for Contractor's selection of a product or material, select an option that is compatible with other products and materials already selected. Total compatibility among options is not assured by limitations within Contract Documents but shall be provided by Contractor. Compatibility is a basic general requirement of product/material selections.
4. Any and all contractor substitutions that require additional work by other trades not specifically called for in the documents shall be paid for by the contractor requesting the substitution if any other trade increase is required.
5. Requested substitution offers Owner a substantial advantage in cost, time, energy conservation, or other considerations, after deducting additional responsibilities Owner must assume. Owner's additional responsibilities may include compensation to Architect/Engineer for redesign and evaluation services, increased cost of other construction by Owner, and similar considerations.

C. Submittals: Submit six (6) copies, utilizing Substitution Request Form, CSI Form 13.1.A, fully identified for product or method being requested for substitution, including related specification section and drawing numbers, and fully documented to show compliance with requirements for substitutions. Include product data/drawings, description of methods, samples where applicable, Contractor's details comparison of significant qualities between specified item and proposed substitution, statement of effect on construction time and coordination with other affected work and contractors, cost information or proposal, warranty information, compatibility with other work, approval of all authorities having jurisdiction, and Contractor's statement to the effect that proposed substitution will result in overall work equal to or better than work originally indicated.

D. Contractor's options for selecting products are limited by Contract Documents requirements, and governing regulations. Required procedures include, but are not necessarily limited to, the following for various indicated methods or specifying:

1. Single product/manufacturer name; provide product indicated or equivalent, except advise Architect/Engineer before proceeding, where known that named product is not a feasible or acceptable selection.
2. Two or more product/manufacturer names; provide one of the named products or equivalent, at Contractor's option; but excluding products which do not comply with requirements. Advise Architect/Engineer before proceeding.
3. Equivalent; where named products in Specifications text are accompanied by the term "or equivalent", or other language of similar effect, comply with those Contract Documents provisions concerning substitutions for obtaining Architect/Engineer's approval of equivalent product.
4. Named, except as otherwise indicated, is defined to mean manufacturer's name for product, as recorded in published product literature, of latest issue as of date of Contract Documents. Refer

- requests to use products of a later or earlier model to Architect/Engineer for acceptance before proceeding.
5. Where compliance with an imposed standard, code or regulation is required, selection from among products that comply with requirements including those standards, codes and regulations, is Contractor's option.
 6. Provide products which comply with specific performances indicated, and which are recommended by manufacturer, in published product literature or by individual certification, for application indicated. Overall performance of a product is implied where product is specified for specific performance.
 7. Provide products that have been produced in accordance with prescriptive requirements, using specified ingredients and components, and complying with specified requirements for mixing, fabricating, curing, finishing, testing and similar operations in manufacturing process.
 8. Where matching of an established sample is required, final judgment of whether a product proposed by Contractor matches sample satisfactorily is Architect/Engineer's judgment. Where no product within specified cost category is available, which matches sample satisfactorily and complies with requirements, comply with Contract Document provisions concerning substitutions for selection of a matching product outside established cost category or not complying with requirements.
 9. Where specified product requirements include "...as selected from manufacturer's full range of colors, patterns, textures..." or words of similar effect, the selection of manufacturer and basic product data is to comply with requirements of the Contract, and selection shall be from the full range of products within the requirements. Where specified product requirements include "... as the industry...", or words to that effect, selection of product complying with requirements, is Architect/Engineer's selection, including designation of manufacturer, where necessary to obtain desired color, pattern or texture.
- E. Substitutions may be permitted by the Architect/Engineer, if, in his opinion, the requirements of the proposed substitution comply with the requirements specified for the material, article or piece of equipment; however, the Architect is not required to permit substitution pursuant to the case of Whitten Corporation vs. Paddock, Incorporated, United States District Court, Massachusetts, April 12, 1974, affirmed by the Federal First Circuit Court, December 14, 1974.
- F. After award of contract, the Contractor may submit substitutes to the Architect for review, fully documented and certified, and accompanied by a proposal for a reduction in the Contract Sum.
- G. Contractor's request for substitution will be received and considered when extensive revisions to Contract Documents are not required and changes are in keeping with general intent of Contract Documents; when timely, fully documented and properly submitted; and when one or more of following conditions is satisfied, all as judged by Architect/Engineer. Otherwise, requests will be returned without action except to record noncompliance with these requirements.
1. Where request is directly related to an "equivalent" clause or other language of same effect in Contract Documents.
 2. Where required product, material or method cannot be provided within Contract Time, but not as a result of Contractor's failure to pursue the work promptly or coordinate various activities properly.
 3. Where required product, material or method cannot be provided in a manner which is compatible with other materials of the work, or cannot be properly coordinated therewith, or cannot be warranted (guaranteed) as required, or cannot be used without adversely affecting Owner's insurance coverage on completed work, or will encounter other substantial non-compliances which are not possible to otherwise overcome except by making requested substitution, which Contractor thereby certifies to overcome such incompatibility, uncoordination, non-warranty, noninsurability or other noncompliance as claimed.

4. Where substantial advantage is offered Owner, in terms of cost, time or other valuable considerations, after deducting offsetting responsibilities Owner may be required to bear, including additional compensation to Architect/Engineer for redesign and evaluation services, increased cost of other work by Owner or separate Contractors, and similar considerations.
- H. Contractor's submittal of, and Architect/Engineer's acceptance of, shop drawings, product data or samples which indicate work not complying with requirements of Contract Documents, does not constitute an acceptable and valid request for, nor approval of, a substitution.

1.5 QUALITY ASSURANCE

- A. Compatibility of Options: If Contractor is given option of selecting between two (2) or more products for use on Project, product selected shall be compatible with products previously selected, even if previously selected products were also options.
1. Each contractor is responsible for providing products and construction methods compatible with products and construction methods of other contractors.
 2. If a dispute arises between contractors over concurrently selectable but incompatible products, Architect/Engineer will determine which products shall be used.

1.6 EQUIVALENT PRODUCTS

- A. Where products or manufacturers are specified by name, Contractor must submit the following, in addition to other required submittals, to obtain approval of an unnamed product proposed as an equivalent:
1. Evidence that the proposed product does not require extensive revisions to the Contract Documents, that it is consistent with the Contract Documents and will produce the indicated results, and that it is compatible with other portions of the Work.
 2. Detailed comparison of significant qualities of proposed product with those named in the specifications. Significant qualities include attributes such as performance, weight, size, durability, visual effect, and specific features and requirements indicated.
 3. Evidence that proposed product provides specified warranty.
 4. List of similar installations for completed projects with project names and addresses and names and addresses of architects and owners, if requested.
 5. Samples, if requested.

1.7 OPERATION AND MAINTENANCE INSTRUCTIONS AND EQUIPMENT WARRANTIES

- A. The Contractor shall orient and instruct the responsible maintenance personnel designated by the Owner in the Operation of all equipment and shall provide the maintenance personnel with pertinent literature and operational manuals for all equipment. Date and time of demonstrations shall be mutually agreed upon with the Owner. Provide qualified personnel for as long as necessary to fully orient and instruct the Owner. Contractor shall videotape instruction session and provide owner with completed video.
- B. The manuals shall be submitted in (quadruplicate) three (3) ring loose-leaf type binders to the Architect for approval with all additional information that the Architect may request and considers necessary for the proper servicing and maintenance of all equipment. Manuals are to include plain paper copies of approved shop drawings and catalog cuts. The quality of the copies may be subject to approval by the

Architect/Engineer. Upon completion and approval, three (3) copies will be forwarded to the Owner and one copy retained by the Architect/Engineer.

C. Manuals shall include no less than the following:

1. Operating Procedures:
 - a. Typewritten procedures indicating each mode of operation of each piece of equipment or system. Procedures shall indicate the status of each component of a system in each operating mode.
 - b. Procedures shall indicate names, symbol numbers, valve tags, circuit numbers, schematic control and wiring diagrams, locations of thermostats, manual starters, control cabinets, and other controls of each system.
 - c. Emergency shutdown procedures for each piece of equipment or system, both automatic and manual as appropriate.
2. Maintenance Schedule: Typewritten schedule describing manufacturer's recommended schedule of maintenance and maintenance procedures.
3. Catalog cuts and shop drawings:
 - a. Catalog cuts shall clearly indicate the exact model and type of each piece of equipment installed in the Project, including all options provided.
 - b. Catalog cuts shall fully describe equipment including physical, electrical, mechanical and other characteristics, performance characteristics and installation or erection diagrams.
 - c. Catalog cuts shall indicate spare part numbers and name, address and telephone number of local representative or service department.
4. Typewritten list of all subcontractors on the Project including name, address, telephone number and responsibility on the Project.
5. Manuals shall be indexed with dividers indicating each system or piece of equipment.
6. Warranties, permits, inspection stickers/approvals and Certificate of Occupancy are to be included.

D. Required equipment warranties shall be submitted in three (3) copies to the Architect/Engineer.

E. The Contractor shall video tape all instructional sessions and demonstrations and provide the Owner with a copy of the videotape at the end of all demonstrations.

PART 2 - PRODUCTS (NOT USED)

PART 3 - EXECUTION

3.1 ACTION ON SUBMITTALS

- A. One copy of all submissions will be returned to the Contractor for his files. The Contractor shall mark up other copies so as to conform with the copy returned to him and forward them to all interested Contractors, Subcontractors, and Suppliers.
- B. The Architect/Engineer will review and stamp submitted shop drawings in one of the following ways (the actual stamp may be different; below language is shown for an example only)
 1. "No Exceptions Taken": Approved.
 2. "Make Corrections Noted": Approved, provided the work complies with corrections marked on the submittal.
 3. "Revise and Resubmit": Do not commence work of this submittal. Revise and resubmit or

- prepare a new submittal; comply with notations marked on submittal.
4. "Rejected": Fundamentally not in compliance. Prepare a new submittal. No notations or comments made.
 - C. Work shall be executed in accordance with "Approved", "Approved As Noted", or "Resubmit for Record" stamp only.
 - D. Architect/Engineer's review of shop drawings/submittals will constitute checking for general arrangement only and shall not relieve the Contractor of responsibility for complete compliance with Drawings and Specifications. Contractor shall be responsible for quantities and dimensions to assure a proper fit under field conditions.

3.2 DISTRIBUTION

- A. Provide additional distribution of submittals, not included in foregoing copy submittal requirements, to subcontractors, suppliers, fabricators, installers, governing authorities and others as necessary for proper performance of the work. Include such additional copies in transmittal to Architect/Engineer where required to receive Action marking before final distribution. Show such distributions on transmittal forms.

3.3 COLOR SELECTIONS

- A. All colors for all finished surfaces and materials will be selected or approved by TCNJ, the TCNJ Athletics Department and the Architect/Engineer. The color selections will be made at **one time** to provide a complete and coordinated color schedule which, upon acceptance of the Owner, will be provided to the Contractor. Any and all specific color selections for materials not noted on drawings or in specification shall be chosen by Architect after submittal of samples.
- B. It is imperative that **all** color information be submitted to TCNJ and the Architect/Engineer by the Contractor before color selections can be made. If any color selection information is not available when colors are needed to meet the project schedule, the Architect/Engineer will select colors from one of the named manufacturers in the Specifications, and the Contractor will be required to exactly match that color. A claim for delay will not be accepted if the color schedule is late due to the failure of the Contractor to provide the Architect/Engineer with all required color information, nor will an extra be entertained if the selected color is not available from the manufacturer the Contractor intended to use but neglected to submit.
- C. The Contractors are reminded of the requirement to declare all substitutions within twenty (20) days of execution of their Contract as specified.

END OF SECTION

SECTION 01310 - QUALITY CONTROL

PART 1 - GENERAL

1.1 TRADESMEN AND WORKMANSHIP

- A. Each Contractor shall ensure that tradesmen performing work at the site are skilled and knowledgeable in methods and craftsmanship needed to produce required quality levels for workmanship in completed work. Remove and replace work which does not comply with workmanship standards as specified and as recognized in the construction industry for applications indicated. Remove and replace other work damaged or deteriorated by faulty workmanship or its replacement.
- B. In certain instances, specification text requires that specific work be assigned to specialists or expert entities, who shall be engaged for performance of those units of work. These shall be recognized as special requirements over which Contractor has no choice or option. These assignments shall not be confused with, and are not intended to interfere with, normal application of regulations, union jurisdictions and similar conventions. One purpose of such assignments is to establish which party or entity involved in a specific unit of work is recognized as "expert" for indicated construction processes or operations. Nevertheless, final responsibility for fulfillment of entire set of requirements remains with Contractor.

1.2 INSPECTION, TESTS AND REPORTS

- A. Required inspection and testing services are intended to assist in determination of probable compliances of the work with requirements, but do not relieve any Contractor of responsibility for those compliances, or for general fulfillment of requirements of Contract Documents. Specified inspections and tests are not intended to limit any Contractor's quality control program. Afford reasonable access to agencies performing tests and inspections.
- B. Contractors are responsible for all testing associated with their work (foundations, soils compaction, concrete, steel, roof material testing etc.) and shall submit the name of their proposed testing agency within fifteen (15) days of Notice-to-Proceed. Each Contractor is responsible to coordinate the activities of the testing agency to assure that work is tested prior to being covered up or other activities associated to the work begin.

PART 2 - PRODUCTS (NOT USED)

PART 3 - EXECUTION

3.1 REPLACEMENT OF WORK

- A. The Contractor shall, within 24 hours after rejection of Work, remove all materials and equipment so rejected and immediately replace said Work, at his cost, to the satisfaction of the Architect/Engineer. Should the Work of the Owner or other Contractors be damaged by such removal or replacement, the Contractor shall reimburse the Owner or other Contractors for all cost incurred for correcting said damage.

3.2 EXAMINATION

- A. Existing Conditions: The existence and location of site improvements, utilities, and other construction indicated as existing are not guaranteed. Before beginning work, investigate and verify the existence and location of underground utilities, mechanical and electrical systems and other construction affecting the Work.
 - 1. Before construction, verify the location and points of connection of utility services.
- B. Existing Utilities: The existence and location of underground and other utilities and construction indicated as existing are not guaranteed. Before beginning sitework, investigate and verify the existence and location of underground utilities and other construction affecting the Work.
 - 1. Before construction, verify the location and invert elevation at points of connection of sanitary sewer, storm sewer, water-service piping and underground electrical services.
 - 2. Furnish location data for work related to Project that must be performed by public utilities serving Project site.
- C. Acceptance of Conditions prior to work starting: Examine substrates, areas, and conditions, with Installer or Applicator present where indicated, for compliance with requirements for installation tolerances and other conditions affecting performance. Record observations.
 - 1. Written Report: Where a written report listing conditions detrimental to performance of the Work is required by other Sections, include the following:
 - a. Description of the Work.
 - b. List of detrimental conditions, including substrates.
 - c. List of unacceptable installation tolerances.
 - d. Recommended corrections.
 - 2. Verify compatibility with and suitability of substrates, including compatibility with existing finishes.
 - 3. Examine roughing-in for electrical systems to verify actual locations of connections before equipment and fixture installation.
 - 4. Proceed with installation only after unsatisfactory conditions have been corrected. Proceeding with the Work indicates acceptance of surfaces and conditions.

3.3 PREPARATION

- A. Existing Utility Information: Furnish information to local utility and Owner that is necessary to adjust, move, or relocate existing utility structures, utility poles, lines, services, or other utility appurtenances located in or affected by construction. Coordinate with authorities having jurisdiction.
- B. Existing Utility Interruptions: Do not interrupt utilities serving facilities occupied by Owner or others unless permitted under the following conditions and then only after arranging to provide temporary utility services according to requirements indicated:
 - 1. Notify Owner not less than two days in advance of proposed utility interruptions.
 - 2. Do not proceed with utility interruptions without Owner's written permission.
- C. Field Measurements: Take field measurements as required to fit the Work properly. Recheck measurements before installing each product. Where portions of the Work are indicated to fit to other construction, verify dimensions of other construction by field measurements before fabrication. Coordinate fabrication schedule with construction progress to avoid delaying the Work.

- D. Space Requirements: Verify space requirements and dimensions of items shown diagrammatically on Drawings.
- E. Review of Contract Documents and Field Conditions: Immediately on discovery of the need for clarification of the Contract Documents, submit a request for information to Architect/Engineer. Include a detailed description of problem encountered, together with recommendations for changing the Contract Documents.

3.4 CONSTRUCTION LAYOUT

- A. Verification: Before proceeding to lay out the Work, verify layout information shown on Drawings, in relation to existing conditions and dimensions. If discrepancies are discovered, notify Architect/Engineer and Owner promptly.

3.5 INSTALLATION

- A. General: Locate the Work and components of the Work accurately, in correct alignment and elevation, as indicated.
 - 1. Make vertical work plumb and make horizontal work level.
 - 2. Where space is limited, install components to maximize space available for maintenance and ease of removal for replacement.
- B. Comply with manufacturer's written instructions and recommendations for installing products in applications indicated.
- C. Install products at the time and under conditions that will ensure the best possible results. Maintain conditions required for product performance until Substantial Completion.
- D. Conduct construction operations so no part of the Work is subjected to damaging operations or loading in excess of that expected during normal conditions of occupancy.
- E. Tools and Equipment: Only use the best quality tools and equipment with proper attenuations for the latest acceptable sound levels.
- F. Anchors and Fasteners: Provide anchors and fasteners as required to anchor each component securely in place, accurately located and aligned with other portions of the Work.
 - 1. Mounting Heights: Where mounting heights are not indicated, mount components at heights directed by Architect/Engineer.
 - 2. Allow for building movement, including thermal expansion and contraction.
- G. Joints: Make joints of uniform width. Where joint locations in exposed work are not indicated, arrange joints for the best visual effect. Fit exposed connections together to form hairline joints.
- H. Hazardous Materials: Use products, cleaners, and installation materials that are not considered hazardous.

END OF SECTION

SECTION 01320 - TEMPORARY FACILITIES

PART 1 - GENERAL

1.1 DESCRIPTION OF REQUIREMENTS

- A. Specific administrative and procedural minimum actions are specified in this section, as extensions of provisions in General Conditions and other Contract Documents. Nothing in this section is intended to limit types and amounts of temporary work required, and no omission from this section will be recognized as an indication that such temporary activity is not required for successful completion of the work and compliance with requirements of Contract Documents.
- B. Each Contractor is specifically assigned certain responsibilities for temporary facilities to be used by all Contractors, other entities at the site, the Owner's work forces and other personnel including occupants of the project, the Owner, the Architect/Engineer, test agencies, personnel of governing authorities, and similar entities and personnel authorized to be at the project site during construction. In general, each Contractor is assigned the responsibilities for installation, operation and removal of each temporary facility which is related by recognized trades to its scope of contract work; and, except as otherwise indicated, each is responsible for costs and use charges associated therewith, including fuel, power usage, water usage and similar usage costs. The Contractor is responsible for temporary facilities not related to any other Contractor's scope of contract work and not otherwise specifically assigned, as designated by the Architect/Engineer.
- C. No costs or usage charges for temporary facilities are chargeable to the Owner, nor can any Contractor's cost or usage charges for temporary facilities be accepted as the basis for a change order extra. The total costs and usage charges for temporary facilities are included, collectively, in the Contract Amounts.

1.2 GENERAL REQUIREMENTS

- A. Each Contractor shall provide and operate all hoists, cranes, helicopters and furnish and erect all ladders and scaffolding required by him and his subcontractors, constructed to afford proper protection to craftsmen, their Work and other Work in progress and previously executed.

1.3 JOB CONDITIONS

- A. Each Contractor shall establish and initiate use of each temporary facility at time first reasonably required for proper performance of the total work of project. Terminate use and remove facilities at earliest reasonable time, when no longer needed or when permanent facilities have, with authorized use, replaced the need.
- B. Each Contractor shall install, operate, maintain and protect temporary facilities in a manner and at locations that will be safe, nonhazardous, sanitary, protective of persons and property, and free of deleterious effects.

1.4 ENVIRONMENTAL PROTECTION

- A. Each Contractor shall provide facilities, establish procedures, and conduct construction activities in a manner that will ensure compliance with environmental and other regulations controlling construction activities at project site. The Contractor shall designate one person, the Construction Superintendent or other, to enforce strict discipline on activities related to generation of wastes, pollution of air/water/soil, generation of noise, and similar harmful or deleterious effects which might violate regulations or reasonably irritate persons at or in vicinity of project site. Anti-pollution measures required by NJDEP, as applicable are to be followed.

1.5 SECURITY

- A. The Contractor shall maintain complete security on the site at all times during and outside of normal working hours to protect the Work and all field offices, and to secure the area of construction by restricting all trespassers.
 - 1. This means locking the doors and/or gates. A guard is not required.

1.6 TEMPORARY CONSTRUCTION FACILITIES

- A. Where mud, snow, ice or other hazardous conditions exist in the purview (Scope of Work) of any Sub Contractor, the Contractor shall remove the hazards immediately and replace with suitable material for the other contractor's use. If the Owner is compelled to remove the hazards with their own forces due to inaction by the Contractor, then that Contractor will be back-charged for the work performed by the Owner.
- B. No welding, cutting by torch, or Work utilizing or causing flammable waste shall be done unless adequate fire protection is provided and maintained for the duration of the Work in the area of operations.

1.7 DEBRIS CONTROL (Refer to Section 01524 for further delineation)

- A. The Contractor shall be responsible for daily cleaning up of spillages and debris resulting from his operations and from those of his Subcontractors; and shall be responsible for complete removal and disposition of hazardous and toxic waste materials. The Contractor shall provide containers at grade, sufficient for the depositing of nonhazardous/nontoxic waste materials and shall remove such waste materials from project site at least weekly during cold weather (daily high temperatures below 50°F) and at least twice weekly during mild and warm weather.
 - 1. Contractor is responsible to provide and pay for all dumpsters.
- B. The Contractor shall daily clean all mud, dirt and debris resulting from all trades operations from the adjacent streets, sidewalks, drives and parking areas and shall repair all damage caused by the cleaning to the satisfaction of the Owner.
- C. The Contractor is to provide and maintain appropriate means of trash disposal (i.e., chutes) to grade/dumpster. Multiple units may be required and shall be figured for in the bid.

PART 2 - PRODUCTS (NOT USED)

PART 3 - EXECUTION

3.1 ENCLOSURES

- A. At earliest possible date, the Contractor shall secure project area against unauthorized entrance at times when personnel are not working. Provide secure temporary enclosure at ground floor and other locations of possible entry, with locked entrances.
- B. Where any form of demolition will expose the interior of the building to weather, demolition shall follow the erection of weatherproof walls by the Contractor installed inside the demolition line, sealed and flashed, as required, to keep all water from the building interior. Keep temporary weatherproofing in place until new construction has been completed to the stage where water will not enter the building.
- C. The Contractor shall provide constant protection against rain, wind, storms, frost or heat to maintain the work, materials, apparatus and fixtures free from damage. At the end of each day's work, cover work likely to be damaged. During cold weather, protect work from damage by freezing and provide such enclosures and heating apparatus as may be necessary diligently to prosecute the Work without stoppage for reason of unfavorable weather.
- D. Wherever a Contractor provides openings through walls or slabs, each location shall be adequately protected at the end of each working day with temporary enclosures to make these areas tight. Openings through exterior walls shall be watertight.
- E. Install an 8-foot high fence around the entire site with wind screening. Provide gates as needed to properly access the site to complete the work. Remove the fence once the project is substantially completed. Fence is to have poles into the ground where the fence will be untouched per a period of time and can have feet with sand bags in areas that the fence may have to be moved occasionally to not interfere with the work.

3.2 TEMPORARY ELECTRICITY

- A. Power is available on site.

3.3 TEMPORARY VENTILATION

- A. A trade requiring ventilation for Work shall provide fans to induce circulation of air.

3.4 TEMPORARY TELEPHONES

- A. Each Contractor is responsible for their own telephone service and for payment of all charges relating to that service.

3.5 TEMPORARY WATER

- A. Water is available on site.

3.6 TEMPORARY SANITARY FACILITIES

- A. Starting at time of start of work at project site, the Contractor shall provide and maintain self-contained toilet units of type acceptable to governing authorities, adequate, at all stages of construction, for use of personnel at project site. Provide separate facilities for male and female personnel when both sexes are working, in any capacity, at project site. Facilities shall remain in use until completion of project. Use of permanent facilities will not be permitted.

3.7 REMOVAL AND RESTORATION

- A. Prior to acceptance of the Project, each contractor shall remove temporary work for which he has been responsible.

3.8 OWNER'S RIGHTS

- A. If any Contractor fails to carry out his responsibilities in providing temporary facilities, as set forth above, the Owner shall have the right to take such action as he deems proper for the protection and conduct of the Work, and to deduct the cost thereof from the amount due the Contractor at fault.
- B. Extended work days, hours, shifts, weekend work, etc. may be allowed upon coordination and approval by the Architect/Engineer and Owner at no additional cost to the Owner.
 - 1. Should the schedule begin to slip, for any reason, the contractor will be required to work additional shifts or weekends to recover the lost time. Should there be a cost to the College for this overtime work, the contractor will be required to reimburse the owner for said costs.

3.9 PARKING

- A. Parking is allowed for two vehicles only. All other parking is to be at the TCNJ Carlton Avenue parking lot. The contractor is responsible to shuttle workers back and forth as needed.

END OF SECTION

SECTION 01322 – PHOTOGRAPHIC DOCUMENTATION

PART 1 - GENERAL

1.1 RELATED DOCUMENTS

- A. Drawings and general provisions of the Contract, including General and Supplementary Conditions and other Division 1 Specification Sections, apply to this Section.

1.2 SUMMARY

- A. This Section includes administrative and procedural requirements for the following work by the General Contractor (other primes are encouraged to document the site and construction, but not required):
 - 1. Preconstruction video and Photographs.
 - 2. Provide photographs and video of various stages of construction.
- B. Related Sections include the following:
 - 1. All of Division 1.

1.3 SUBMITTALS

- A. Qualification Data: For photographer.
- B. Videos and Photographs: Submit three (3) copies of each video with protective case within seven days of recording. Submit 1 copy of photographs in a binder and one (1) copy electronically on a CD or thumb drive.
 - 1. Identification: On each copy, provide an applied label with the following information:
 - a. Name of Project.
 - b. Name and address of photographer.
 - c. Name of Architect/Engineer.
 - d. Name of Contractor.
 - e. Date photographs were taken or videos were recorded.
 - f. Description of vantage point, indicating location, direction (by encompass point), and elevation or story of construction.

1.4 QUALITY ASSURANCE

- A. Photographer Qualifications: An individual who has been regularly engaged as a professional photographer of construction products for not less than three (3) years.

1.5 COORDINATION

- A. Auxiliary Services: Cooperate with photographer and provide auxiliary services requested, including access to project site and use of temporary facilities, including temporary lighting required to produce clear, well-lit photographs without obscuring shadows.

1.6 USAGE RIGHTS

- A. Obtain and transfer copyright usage rights from photographer to Owner for unlimited reproduction of photographic documentation.

PART 2 - PRODUCTS

2.1 PHOTOGRAPHIC MEDIA

- A. Digital format as agreed to at the project kick off meeting.

PART 3 - EXECUTION

3.1 CONSTRUCTION VIDEOS

- A. Digital Photographer: Engage a qualified commercial videographer to record construction digital recordings.
- B. Preconstruction: Before starting demolition or construction record, videotape (digital) of Project site, interior and exterior.
 - 1. Show protection efforts by the Contractor.

END OF SECTION

SECTION 01330 – CONTRACT CLOSEOUT

PART 1 - GENERAL

1.1 DEFINITION

- A. Closeout is hereby defined to include general requirements near end of Contract Time, in preparation for final acceptance, final payment, normal termination of Contract, occupancy by Owner and similar actions evidencing completion of the work. Specific requirements for individual units of work are specified in sections of Divisions 2 through 16. Time of closeout is directly related to Substantial Completion, and therefore may be either a single time period for entire work or a series of time periods for individual parts of the work which have been certified as substantially complete at different dates. That time variation, if any, shall be applicable to other provisions of this section.
- B. Substantial completion shall be defined that every material item has been installed. Nothing is missing and therefore, the punch list can begin.

1.2 PREREQUISITES TO SUBSTANTIAL COMPLETION

- A. Prior to requesting the Architect/Engineer's inspection for certification of substantial completion, for either entire work or portions thereof, complete the following and list known exceptions in request:
 - 1. In progress payment request coincident with or first following date claimed, show either 100% completion for portion of work claimed as substantially complete, or list incomplete items, value of incomplete items, and reasons for being incomplete.
 - 2. Include supporting documentation for completion as indicated in these Contract Documents.
 - a. Prepare a list of items to be completed and corrected (punch list), the value of items on the list, and reasons why the Work is not complete.
 - 3. Submit statement showing accounting of changes to the Contract Sum.
 - 4. Advise Owner of pending insurance change over requirements.
 - 5. Submit specific warranties, workmanship/maintenance bonds, maintenance agreements, final certifications and similar documents.
 - 6. All fire sprinklers, devices, alarm system, roofing system, doors, insulation, etc. requiring FM Research approval to submit certification from Factory Mutual.
 - 7. Obtain and submit releases enabling Owner's full and unrestricted use of the work and access to services and utilities, including occupancy permits, operating certificates, and similar releases.
 - 8. Deliver tools, spare parts, extra stocks of materials, and similar physical items to Owner obtaining a signed receipt of materials delivered. Refer to individual work sections for required quantities of spare parts, extra and overrun stock, maintenance tools and devices, keys, and similar physical units to be submitted.
 - 9. Complete start up testing of systems, and instructions of Owner's operating/maintenance personnel. Discontinue, or change over, and remove from project site temporary facilities and services, along with construction tools and facilities, mockups, and similar elements.
 - 10. Complete final clean up requirements.
 - 11. Touch up and otherwise repair and restore marred exposed finishes.
 - 12. Inspection: Submit a written request for inspection for Substantial Completion to Project Manager. On receipt of request, Architect and Project Manager will either proceed with inspection or notify Contractor of unfulfilled requirements. Architect/Engineer will prepare the Certificate of Substantial Completion after inspection, the Project Manager will notify Contractor

of items, either on Contractor's list or additional items identified by Architect/Engineer that must be completed or corrected before certificate will be issued.

- a. Reinspection: Request reinspection when the Work identified in previous inspections as incomplete is completed or corrected.
 - b. Results of completed inspection will form the basis of requirements for Final Completion.
- B. Upon receipt of Contractor's request, the Project Manager and Architect/Engineer will proceed with substantial completion inspection. Following inspection, the Architect/Engineer will either prepare the certificate of substantial completion, or advise the Contractor of work which shall be performed prior to issuance of certificate. The work remaining to be performed shall be completed prior to the punch list for final acceptance.
- C. Upon receipt of Contractor's notice that work has been completed, including all punch list items, but excepting incomplete items delayed because of circumstances acceptable to the Project Manager and Architect, the Project Manager and Architect/Engineer will reinspect the work. Upon completion of reinspection, the Architect/Engineer will either prepare the certificate of final acceptance or advise the Contractor of work not completed or obligations not fulfilled as required for final acceptance.
- D. In the event that the work is not completed or obligations are not fulfilled as required for final acceptance and the Engineer is required to reinspect the work more often than the two (2) inspections described, the Contractor shall compensate the Architect/Engineer and/or the Project Manager at the rate of \$500.00 for each additional site visit required for reinspection. The compensation shall be processed by change order as a deduction to the Contractor's Contract Sum, which amount will be paid to the Architect/Engineer or Project Manager by the Owner, through a change order as an addition to the Architect/Engineer's or Project Manager's Contract Sum.
- E. Substantial Completion shall be defined for this project that every element of the project/construction and the contract, based on the contract and amended drawings and specification sections, are installed and the building is deemed complete, less repairs and/or touch up type work that would be generally referred to as punch list work. If any components of the building, or site work associated with this contract are not installed, the project cannot be deemed substantially completed.

1.3 PREREQUISITES TO FINAL ACCEPTANCE

- A. Prior to requesting Project Manager and Architect/Engineer's final inspection for certification of final acceptance and final payment, complete the following and list known exceptions, in request:
1. Submit final payment request with final releases and supporting documentation not previously submitted and accepted. Include certificates of insurance for products and completed operations where required.
 2. Submit release of liens for all subcontractors.
 3. Submit Contractor's statement that his final application, as presented, is the final bill and no other claims will be presented.
 4. Submit updated final statement, accounting for additional changes to Contract Sum including change orders and allowances.
 5. Submit certified copy of Architect/Engineer's final punch list of itemized work to be completed or corrected, stating that each item has been completed or otherwise resolved for acceptance, endorsed and dated by Architect/Engineer.
 6. Submit one set of record documents, bound copies of maintenance/operating manuals, final project photographs, damage or settlement survey, property survey, and similar final record information.
 7. Complete final clean up requirements.

8. Touch up and otherwise repair and restore marred exposed finishes.
 9. Submit notarized consent of surety to final payment.
 10. Submit final liquidated damages settlement statement, if required, acceptable to Project Manager and the Owner.
 11. Revise and submit evidence of final, continuing insurance coverage complying with insurance requirements.
 12. A letter from the Owner's representative certifying that he has been properly instructed in the operation and maintenance of equipment by the Contractor.
 13. Ten percent (10%) one-year Maintenance Bond.
 14. Underwriter's Certificate or Electrical Sub Code Official's Approval.
 15. Final acceptance by Architect/Engineer of record documents.
- B. Except as otherwise indicated or requested by Project Manager/Architect, remove temporary protection devices and facilities that were installed during course of the work to protect previously completed work during remainder of construction period.

1.4 CLEAN UP

- A. Remove waste materials from site and dispose of in a lawful manner.

PART 2 - PRODUCTS (NOT USED)

PART 3 - EXECUTION

3.1 CLEANING

- A. Where extra materials of value remaining after completion of associated work have become Owner's property, dispose of these to Owner's best advantage as directed.
- B. After Substantial Completion of the Work, each Contractor shall do the final cleaning of the surfaces of his installations as may be required by the various Specification sections.
- C. After each Contractor has cleaned their work, The General Contractor shall engage a professional cleaning service to perform final cleaning of the work consisting of cleaning each surface or unit to normal clean condition. Comply with manufacturer's instructions for cleaning operations and chemicals. The following are examples, but not by way of limitation, of cleaning levels required:
1. Remove labels that are not required as permanent labels.
 2. Clean transparent materials, including mirrors and window/door glass, to a polished condition, removing substances that are noticeable as vision obscuring materials. Replace broken glass and damaged transparent materials.
 3. Clean exposed exterior and interior hard surfaced finishes, to a dirt-free condition, free of dust, stains, films and similar noticeable distracting substances. Except as otherwise indicated, avoid disturbance of natural weathering of exterior surfaces. Restore reflective surfaces to original reflective conditions.
 4. Wipe surfaces of mechanical and electrical equipment clean, including elevator equipment and similar equipment; remove excess lubrication and other substances.
 5. Remove debris and surface dust from limited access spaces including trenches, equipment vaults, manholes and similar spaces.

6. Clean Project site, yard, and grounds, in areas disturbed by construction activities, including landscape development areas, of rubbish, waste material, litter, and other foreign substances.
7. Sweep paved areas broom clean. Remove petrochemical spills, stains, and other foreign deposits.
8. Rake grounds that are neither planted nor paved to a smooth, even-textured surface.
9. Remove tools, construction equipment, machinery, and surplus material from Project site.
10. Clean exposed exterior hard-surfaced finishes to a dirt-free condition, free of stains, films, and similar foreign substances. Avoid disturbing natural weathering of exterior surfaces. Restore reflective surfaces to their original condition.
11. Replace parts subject to unusual operating conditions.
12. Leave Project clean and ready for occupancy.

D. Comply with safety standards for cleaning. Do not burn waste materials. Do not bury debris or excess materials on Owner's property. Do not discharge volatile, harmful, or dangerous materials into drainage systems. Remove waste materials from Project site and dispose of lawfully.

3.2 RECORD DOCUMENTS (Refer to Section 01340, project requirements for submitting Record Documents)

3.3 REMOVE TEMPORARY FACILITIES

A. At the completion of the work prior to final payment, remove all temporary facilities entirely from site, including, but not limited to, the following: Field offices, trailers, shanties, sheds, job telephone, temporary toilets, temporary enclosures, dust barriers and other temporary protection devices.

END OF SECTION

SECTION 01340 - PROJECT RECORD DOCUMENTS

PART 1 - GENERAL

1.1 SUMMARY

- A. Section Includes:
1. Project record documents consisting of:
 - a. Record drawings.
 - b. Record project manual (specifications).

1.2 SUBMITTALS

- A. Project Record Documents: Submit after substantial completion, but prior to final completion.
1. Record drawings: Submit in form of opaque prints.
 - a. Sets shall include all drawings, whether changed or not.
 2. Other record documents: Submit originals or good quality photocopies.
 3. Each Sub contractor is responsible for their respective trade, record documents and record drawings. Combine with General Contractor record drawing documents for a complete set.

PART 2 - PRODUCTS (NOT USED)

PART 3 - EXECUTION

3.1 MAINTENANCE OF PROJECT RECORD DOCUMENTS

- A. Do not use record documents of any type for construction purposes.
- B. Maintain record documents in a secure location at the site while providing for access by the contractor and the Architect/Engineer during normal working hours; store in a fire-resistive room or container outside of normal working hours.
- C. Record information as soon as possible after it is obtained.
- D. Assign a person or persons responsible for maintaining record documents.
- E. Record the following types of information on all applicable record documents:
1. Dimensional changes.
 2. New and revised details.
 3. Revisions to electrical circuits.
 4. Locations of utilities concealed in construction.
 5. Particulars on concealed products which will not be easy to identify later.
 6. Changes made by modifications to the contract; note identification numbers if applicable.
 7. New information which may be useful to the owner, but which was not shown in either the contract documents or submittals.

3.2 RECORD DRAWINGS

- A. Maintain a complete set of opaque prints of the contract drawings, marked to show changes.
- B. Where the actual work differs from that shown on the drawings, mark this set to show the actual work.
 - 1. Mark location of concealed items before they are covered by other work.
 - 2. Mark either record contract drawings or shop drawings, whichever are best suited to show the change.
- C. When the contractor is required by a provision of a modification to prepare a new drawing, rather than to revise existing drawings, obtain instructions from the architect as to the drawing scale and information required.
- D. Keep drawings in labeled, bound sets.
 - 1. Mark with red pencil.
 - 2. Mark work of separate contracts with different colors of pencils.
 - 3. Incorporate new drawings into existing sets, as they are issued.
- E. Where record drawings are also required as part of operation and maintenance data submittals, copy marks to another opaque print obtained from the Architect/Engineer.

3.3 RECORD PROJECT MANUAL

- A. Maintain a complete copy of the project manual, marked to show changes.
- B. Where the actual work differs from that shown in the project manual, mark the record copy to show the actual work.
 - 1. Include a copy of each addendum and modification to the contract.
 - 2. In addition to the types of information required on all record documents, record the following types of information:
 - a. Product options taken, when the specification allows more than one.
 - b. Proprietary name and model number of actual products furnished, for each product, material, and item of equipment specified.
 - c. Name of the supplier and installer, for each product for which neither a product data submittal nor a maintenance data submittal was specified.

3.4 TRANSMITTAL TO OWNER (through the Architect/Engineer)

- A. Collect, organize, label, and package ready for reference.
 - 1. Bind print sets with durable paper covers.
 - 2. Label each document (and each sheet of drawings) with "PROJECT RECORD DOCUMENTS - This document has been prepared using information furnished by _____" [insert the contractor's name], and the date of preparation.
- B. Submit to the Project Manager for transmittal to the Architect/Engineer, unless otherwise indicated.

- C. Submit to the Architect/Engineer four (4) sets of Operation and Maintenance Manuals in three-ring binders, by volume, and indexed per binder (with one master index) to be transmitted to the Architect/Engineer for approval: All to be submitted at one time, not piece meal. Indexing should follow the specification section numbers.
1. Include all inspection/approvals/certifications
 2. All approved submittals and cut sheets as well as manufacturer's operation and maintenance manuals for each section.
 3. Manuals are to be completed in volumes, three ring binders, starting with Division 1 and continuing through the last projects Division. The number of volumes is determined by the number of spec section the projects has and by the amount of paper/copies for complete sets of three ring binders.
 4. List of all contractors and vendors for the project with names, addresses and phone numbers.

END OF SECTION

SECTION 01524 – CONSTRUCTION WASTE MANAGEMENT

PART 1 - GENERAL

1.1 RELATED DOCUMENTS

- A. Drawings and general provisions of the Contract, including General and Supplementary Conditions and Division 1 Specification Sections, apply to this Section.

1.2 SUMMARY

- A. This Section includes administrative and procedural requirements for the following:
 - 1. Salvaging nonhazardous demolition and construction waste.
 - 2. Recycling nonhazardous demolition and construction waste.
 - 3. Disposing of nonhazardous demolition and construction waste.
- B. Related Sections include the following:
 - 1. All of Division 1 and attached specifications and drawings that make a part of this contract.

1.3 DEFINITIONS

- A. Construction Waste: Site improvement materials and other solid waste resulting from construction, remodeling, renovation, or repair operations. Construction waste includes packaging.
- B. Demolition Waste: Site improvement materials resulting from demolition or selective demolition operations.
- C. Disposal: Removal off-site of demolition and construction waste and subsequent sale, recycling, reuse, or deposit in landfill or incinerator acceptable to authorities having jurisdiction.
- D. Recycle: Recovery of demolition or construction waste for subsequent processing in preparation for reuse.
- E. Salvage: Recovery of demolition or construction waste and subsequent sale or reuse in another facility.

1.4 SUBMITTALS

- A. Waste Management Plan: Submit four (4) copies of plan within 30 days of date established for the Notice to Proceed.
- B. Records of Donations: Indicate receipt and acceptance of salvageable waste donated to individuals and organizations. Indicate whether organization is tax exempt.
- C. Records of Sales: Indicate receipt and acceptance of salvageable waste sold to individuals and organizations. Indicate whether organization is tax exempt.

- D. Recycling and Processing Facility Records: Indicate receipt and acceptance of recyclable waste by recycling and processing facilities licensed to accept them. Include manifests, weight tickets, receipts, and invoices.
- E. Landfill and Incinerator Disposal Records: Indicate receipt and acceptance of waste by landfills and incinerator facilities licensed to accept them. Include manifests, weight tickets, receipts, and invoices.

1.5 QUALITY ASSURANCE

- A. Regulatory Requirements: Comply with hauling and disposal regulations of authorities having jurisdiction.
- B. Waste Management Conference: Conduct conference at Project site to comply with requirements in Division 1. Review methods and procedures related to waste management including, but not limited to, the following:
 - 1. Review and discuss waste management plan.
 - 2. Review requirements for documenting quantities of each type of waste and its disposition.
 - 3. Review and finalize procedures for materials separation and verify availability of containers and bins needed to avoid delays.
 - 4. Review procedures for periodic waste collection and transportation to recycling and disposal facilities.
 - 5. Review waste management requirements for each trade.

1.6 WASTE MANAGEMENT PLAN

- A. General: Develop plan consisting of waste identification, and waste reduction work plan. Indicate quantities by weight or volume but use same units of measure throughout waste management plan.
- B. Waste Identification: Indicate anticipated types and quantities of demolition, site-clearing, and construction waste generated by the Work. Include estimated quantities and assumptions for estimates.
- C. Waste Reduction Work Plan: List each type of waste and whether it will be salvaged, recycled, or disposed of in landfill or incinerator. Include points of waste generation, total quantity of each type of waste, quantity for each means of recovery, and handling and transportation procedures.
 - 1. Salvaged Materials for Sale: For materials that will be sold to individuals and organizations, include list of their names, addresses, and telephone numbers.
 - 2. Salvaged Materials for Donation: For materials that will be donated to individuals and organizations, include list of their names, addresses, and telephone numbers.
 - 3. Recycled Materials: Include list of local receivers and processors and type of recycled materials each will accept. Include names, addresses, and telephone numbers.
 - 4. Disposed Materials: Indicate how and where materials will be disposed of. Include name, address, and telephone number of each landfill and incinerator facility.
 - 5. Handling and Transportation Procedures: Include method that will be used for separating recyclable waste including sizes of containers, container labeling, and designated location on Project site where materials separation will be located.

PART 2 - PRODUCTS (NOT USED)

PART 3 - EXECUTION

3.1 PLAN IMPLEMENTATION

- A. General: Implement waste management plan as approved by Project Manager. Provide handling, containers, storage, signage, transportation, and other items as required to implement waste management plan during the entire duration of the Contract.
 - 1. Comply with Division 1 Section "Temporary Facilities" for operation, termination, and removal requirements.
- B. Training: Train workers, subcontractors, and suppliers on proper waste management procedures, as appropriate for the Work occurring at Project site.
 - 1. Distribute waste management plan to entities when they first begin work on-site. Review plan procedures and locations established for salvage, recycling, and disposal.
- C. Site Access and Temporary Controls: Conduct waste management operations to ensure minimum interference with roads, streets, walks, walkways, and other adjacent occupied and used facilities.
 - 1. Designate and label specific areas on Project site necessary for separating materials that are to be salvaged, recycled, reused, donated, and sold.
 - 2. Comply with Division 1 Section "Temporary Facilities and Controls" for controlling dust and dirt, environmental protection, and noise control.

3.2 SALVAGING DEMOLITION WASTE

- A. Salvaged Items for Sale and Donation: Not permitted on Project site.

3.3 RECYCLING DEMOLITION AND CONSTRUCTION WASTE, GENERAL

- A. General: Recycle beverage containers used by on-site workers.
- B. Recycling Incentives: Revenues, savings, rebates, tax credits, and other incentives received for recycling waste materials shall accrue to the Contractor.
- C. Procedures: Separate recyclable waste from other waste materials, trash, and debris. Separate recyclable waste by type at Project site to the maximum extent practical.
 - 1. Provide appropriately marked containers or bins for controlling recyclable waste until they are removed from Project site. Include list of acceptable and unacceptable materials at each container and bin.
 - a. Inspect containers and bins for contamination and remove contaminated materials if found.
 - 2. Stockpile processed materials on-site without intermixing with other materials. Place, grade, and shape stockpiles to drain surface water. Cover to prevent windblown dust.
 - 3. Stockpile materials away from construction area.
 - 4. Store components off the ground and protect from the weather.
 - 5. Remove recyclable waste off Owner's property and transport to recycling receiving or processor.

3.4 RECYCLING DEMOLITION WASTE

- A. Asphaltic Concrete Paving: Break up and transport paving to asphalt-recycling facility.
- B. Concrete: break up and sort rebar as best as possible. Recycle all concrete.
- C. Recycle all metal products from the building before demolition (aluminum, steel etc.)
- D. Recycle as much product as possible and provide a complete report to TCNJ to confirm the percentage recycled on the project.

3.5 RECYCLING CONSTRUCTION WASTE

- A. Packaging:
 - 1. Cardboard and Boxes: Break down packaging into flat sheets. Bundle and store in a dry location.
 - 2. Polystyrene Packaging: Separate and bag materials.
 - 3. Pallets: As much as possible, require deliveries using pallets to remove pallets from Project site. For pallets that remain on-site, break down pallets into component wood pieces and comply with requirements for recycling wood.
 - 4. Crates: Break down crates into component wood pieces and comply with requirements for recycling wood.
- B. Wood Materials:
 - 1. Clean Cut-Offs of Lumber: Grind or chip into small pieces.

3.6 DISPOSAL OF WASTE

- A. General: Except for items or materials to be salvaged, recycled, or otherwise reused, remove waste materials from Project site and legally dispose of them in a landfill or incinerator acceptable to authorities having jurisdiction.
 - 1. Except as otherwise specified, do not allow waste materials that are to be disposed of accumulate on-site.
 - 2. Remove and transport debris in a manner that will prevent spillage on adjacent surfaces and areas.
- B. Burning: Do not burn waste materials on site.
- C. Burying: Do not bury waste materials on site.
- D. Disposal: Transport waste materials off Owner's property and legally dispose of them.
- E. Washing waste materials into sewers or drains is not permitted.

END OF SECTION

SECTION 017836 - WARRANTIES

PART 1 - GENERAL

1.1 DEFINITIONS

- A. Within this Section, the term Warranty shall be used to mean warranties of various types, equipment performance certifications, and similar performance guarantees, or Service / Maintenance Agreements.
- B. Within this Section, the term Product shall be used to mean equipment, systems, products, components, and other similar aspects of the Work that have a manufacturer's or installer's warranty, or Service/ Maintenance Agreements.

1.2 GENERAL WARRANTY REQUIREMENTS

- A. Basic construction warranty of work is outlined in the General Conditions of the Contract.
- B. Specific Product warranties are identified in the various Technical Specification sections.
- C. Each Separate Prime Contractor shall provide the basic construction warranty, shall provide his own two (2) year Maintenance Bond, if required, and shall be responsible for any required Product warranties, related to his own Contract.
- D. Manufacturer's disclaimers and limitations on product warranties do not relieve the Contractor of the warranty on the Work that incorporates the products, nor does it relieve suppliers, manufacturers, and subcontractors required to countersign special warranties with the Contractor.
- E. Written warranties made to The College of New Jersey are in addition to implied warranties, and shall not limit the duties, obligations, rights, and remedies otherwise available under law. Warranty periods shall not be interpreted as limitations on time in which The College of New Jersey can enforce such other duties, obligations, rights, or remedies as established by the Uniform Commercial Code (UCC).
- F. The College of New Jersey reserves the right to reject warranties and to limit selections to products with warranties not in conflict with requirements of the Contract Documents.
- G. Where a special warranty is required on the Work or part of the Work, The College of New Jersey reserves the right to refuse to accept the Work until the responsible entities countersign such warranty.
- H. Upon determination by The College of New Jersey that Work covered by a warranty, or Service Agreement has failed, the Contractor shall replace or rebuild the Work to an acceptable condition complying with requirements of Contract. The Contractor is responsible for the total cost of replacing or rebuilding defective Work regardless of whether The College of New Jersey benefits from use of the Work through a portion of its anticipated useful service life.
- I. When correcting warranted Work that has failed, the Contractor shall remove and replace other Work that has been damaged as a result of such failure or that must be removed and replaced to provide access for correction of warranted Work.
- J. When Work covered by a warranty, or Service Agreement has failed and been corrected by replacement or rebuilding, the warranty, or Service Agreement shall be reinstated by the Contractor

by written endorsement. The reinstated warranty shall be equal to the original warranty with an equitable adjustment for depreciation.

- K. In the event the Contractor fails to commence and diligently pursue any warranty work required, The College of New Jersey may have the work performed by others, and after completion of the work, charge the cost of the work, and any reasonable and necessary expenses associated with the work incurred by the University, to the Contractor. In the event sufficient funds are not remaining in the Contract to cover the cost and expenses incurred, The College of New Jersey will have the right to recoup expenses by other legal means.

1.3 WARRANTY PERIODS

- A. Warranties shall commence on the Substantial Completion Date, unless one of the following apply.
1. The Certificate of Substantial Completion designates a warranty commencement date, other than the Substantial Completion Date, for certain Work or portions of Work.
 2. By separate agreement between the Contractor and The College of New Jersey, a designated and completed portion of the Work is occupied or used by The College of New Jersey during the construction period, in which case any warranty, or Service Agreement related to that Work or portions of the Work shall commence when the occupancy or use begins.

1.4 SUBMITTAL OF PRODUCT WARRANTIES

- A. Written product warranties shall be submitted to The College of New Jersey within fifteen (15) days of Substantial Completion. If another date is specified per paragraph 1.3 above, written warranties shall be submitted within fifteen (15) days of that other date.
- B. When a special warranty, or Service Agreement is required to be executed by the Contractor, or by the Contractor and a subcontractor, supplier, or manufacturer, the Contractor shall prepare a written document for execution by the required parties that contains appropriate terms and identification. A draft of the written document shall be submitted to The College of New Jersey for acceptance prior to final execution.
- C. When Operating and Maintenance Manuals are required for warranted construction, an additional copy of each required warranty shall be provided, as necessary, with each Operating and Maintenance Manual.

1.5 SUBMITTAL OF WARRANTY PLAN

- A. Each Separate Prime Contractor shall prepare and submit a Warranty Plan which outlines the responsibilities and procedures to address warranty issues arising from the Contract and the Work. Each Separate Prime Contractor's Warranty Plan shall include information relative to his own portion of the Work and to product warranties related to his own Contract.
- B. Prior to Substantial Completion, the Contractor shall meet with The College of New Jersey to develop a mutual understanding with respect to the requirements of the Warranty Plan. Communication procedures for notification of construction warranty defects, priorities with respect to the type of defect, reasonable time required for Contractor response, and other details deemed necessary by The College of New Jersey for the execution of the warranty shall be established and reviewed at this meeting. Based on the information provided at the meeting, the Contractor shall submit to The College of New Jersey a written Warranty Plan.

- C. The Warranty Plan shall generally include all information required to assure that The College of New Jersey receives all warranties to which it is entitled and can take action with respect to calls against the warranties. The Plan shall be in sufficient detail to render it suitable for use by future College of New Jersey operations and maintenance personnel, and tailored as appropriate for the specific Contract.
- D. The Warranty Plan shall include the following information.
1. The Plan shall identify key personnel associated with the warranty process, to include their specific roles and responsibilities, and their telephone numbers and other means of contact. Key personnel should be from within the organizations of the Contractor, subcontractors, manufacturers, and suppliers involved. The Contractor may choose to furnish the name, telephone number and address of a licensed and bonded company, other than itself, authorized to directly initiate and pursue warranty work on its behalf. Doing so does not relieve the Contractor of any of its responsibilities in connection with their responsibility for warranting the Work.
 2. The Plan shall provide a list of all product warranties and special warranties, or Service Agreement required by the Contract Documents. This list shall also provide the status of delivery of each of these warranties.
 3. The Plan shall provide a list of each warranted product. This list shall include the following:
 - a. name of item
 - b. model number
 - c. serial number
 - d. location where installed
 - e. name and phone numbers of manufacturer
 - f. name and phone numbers of installer
 - g. names, addresses, and telephone numbers of sources of spare parts
 - h. organization, names, and phone numbers of persons to call for warranty service
 - i. typical response time and repair time expected for various warranted equipment
 - j. term of warranty (starting point and end point of warranty period)

1.6 TEN-MONTH WARRANTY INSPECTION

- A. Ten (10) months after the date for Substantial Completion, The College of New Jersey will conduct an inspection of the facility, and based on the inspection, prepare and provide to the Contractor a list of warranty work items that are required to be replaced or repaired under the terms of the warranty provisions of the Contract. The Contractor may be invited to participate in this inspection, but his participation is not mandatory.
- B. Upon receipt of the list of warranty work items, the Contractor shall provide to The College of New Jersey a response containing his planned actions and dates for those actions relative to the identified warranty work items. The Contractor shall complete all work items not later than twelve (12) months after the date for Substantial Completion.

PART 2 - PRODUCTS (NOT USED)

PART 3 - EXECUTION (NOT USED)

END OF SECTION

SECTION 311000 - SITE CLEARING

PART 1 GENERAL

1.1 RELATED DOCUMENTS

- A. Drawings and general provisions of the Contract, including Instructions to Bidders, General Conditions, and Supplementary Instructions to Bidders and General Conditions, and other Division 1 Specification Sections, apply to this Section.
- B. Related Sections include the following:
 - 1. Refer to Division 01 Section 01100 "Project Procedures" for temporary utilities, temporary construction and support facilities, temporary security and protection facilities, and temporary erosion and sedimentation control procedures.
 - 2. Refer to Division 01 Section 01100 "Project Procedures" for verifying utility locations and for recording field measurements.
 - 3. Refer to Division 31 Section 312000 "Earth Moving" for excavating, backfilling, and site grading.

1.2 SUMMARY

- A. This Section includes the following:
 - 1. Clearing and grubbing.
 - 2. Removing above- and below-grade site improvements including selective/partial demolition and removal of existing improvements.
 - 3. Disconnecting, capping or sealing, abandoning, and removal of above- and below-grade site utilities.
 - 4. Cleaning and protection of existing drainage structures and pipes.
 - 5. Temporary erosion and sedimentation control measures.
- B. All site clearing activities and sediment control measures are to be performed as part of the Base Bid.

1.3 MATERIAL OWNERSHIP

- A. Except for materials indicated to remain Owner's property, cleared materials shall become Contractor's property and shall be removed from Project site.
- B. The Owner shall retain right of first refusal on all utility structures indicated to be removed as a part of the work in this section

1.4 SUBMITTALS

- A. Photographs or videotape, sufficiently detailed, of existing conditions of adjoining construction and site improvements that might be misconstrued as damage caused by site clearing.
- B. Record drawings, according to other Sections of the Specification identifying and accurately locating capped utilities and other subsurface structural, electrical, and mechanical conditions.

1.5 QUALITY ASSURANCE

- A. Pre-installation Conference: Conduct conference at Project site to comply with requirements in Division 01 Section 01100 "Project Procedures".

1.6 PROJECT CONDITIONS

- A. Traffic: Minimize interference with adjoining roads, streets, parking areas, pedestrian zones, walks, and other adjacent occupied or used facilities during site-clearing operations.
 - 1. Do not close or obstruct streets, walks, or other adjacent occupied or used facilities without permission from Owner and authorities having jurisdiction.
 - 2. Provide alternate routes around closed or obstructed traffic ways if required by authorities having jurisdiction.
 - 3. There are no proposed improvements on adjoining property for this project.
- B. Salvable Improvements: Carefully remove items indicated to be salvaged and store on Owner's premises or designated area where indicated.
- C. Utility Locator Service: Notify utility locator service for area where Project is located before site clearing. New Jersey One-Call must be contacted at 1-800-272-1000 at least three (3) full working days, but not more than ten (10) days, prior to the planned start date of the excavation or site clearing operations.
- D. Do not commence site clearing operations until temporary erosion and sedimentation control measures are in place.

PART 2 PRODUCTS - Not used.

PART 3 EXECUTION

3.1 PREPARATION

- A. Protect and maintain benchmarks and survey control points from disturbance during construction.
- B. Locate and clearly flag trees and vegetation to remain or to be relocated.
- C. Protect existing site improvements to remain from damage during construction.
 - 1. Restore damaged improvements to their original condition, as acceptable to Owner.

3.2 TEMPORARY EROSION AND SEDIMENTATION CONTROL

- A. Provide temporary erosion and sedimentation control measures to prevent soil erosion and discharge of soil-bearing water runoff or airborne dust to adjacent properties and walkways, as required by the Soil Erosion and Sediment Control Standards of New Jersey and as directed by the Engineer. Install any additional erosion and sediment control measures as necessary to meet the directives of the Engineer during the Work. Although a site specific soil erosion permit has not been obtained, the Contractor is responsible for furnishing, installing and maintaining any and all soil erosion measures such as inlet filters, silt fence, etc. as shown in plans, or deemed reasonable by the Engineer.

- B. Inspect, repair, and maintain erosion and sedimentation control measures during construction until permanent vegetation has been established.
- C. Remove erosion and sedimentation controls and restore and stabilize areas disturbed during removal.

3.3 UTILITIES

- A. Locate, identify, disconnect, and seal or cap off utilities indicated to be removed and/or abandoned.
 - 1. Contractor shall arrange with utility companies to shut off site utilities to be removed.
- B. Existing Utilities: Do not interrupt utilities serving facilities occupied by Owner or others unless permitted under the following conditions and then only after arranging to provide temporary utility services according to requirements indicated:
 - 1. Do not proceed with utility interruptions without A/E's written permission.
 - 2. Protect underground utilities if exposed by Work.
- C. Proposed Utilities
 - 1. The Contractor is also responsible under the Site Clearing item for the protection of the public, equipment and proposed installed structures for the duration of the construction period. This shall include installation of temporary fencing around disturbed areas, pedestrian walkway bypasses and construction signage.
- D. Cleaning of Existing Drainage Structures and Pipes
- E. Site Clearing shall also include the silt and sediment removal from all inlets, as well as the removal of grass, scale, and other debris from the associate grates within the limits of the project site and all piping and structures interconnected to the piping within the limits of the school property. This includes disposal of all removed materials and photographic documentation of conditions to the engineer.
 - 1. At least five (5) days before beginning the work, submit a plan to the Engineer detailing the proposed method and equipment to be used. Remove and collect silt, debris, and material. Ensure that the material is not discharged into the drainage system. Dispose of materials removed from the existing structure in accordance with paragraph 3.8 below.
 - 2. The work shall include all labor, tools, equipment and related items as may be required for the complete cleaning and jetting of the site's storm drainage system and removing and disposing of all deposits cleaned from the drains.
- F. Cleaning Procedures and Equipment.
 - 1. The Contractor shall clean storm drain structures and piping prior to internal inspection, utilizing cleaning equipment approved for use by the Engineer. The Contractor shall ensure that the scope of work assumed during bidding shall be sufficient for removing all shapes, sizes and quantities of debris.
 - 2. Cleaning equipment may consist of hydraulic high-pressure jet machines, heavy duty power rodding machines capable of cleaning distances applicable to the site in one step and heavy-duty bucket machines that can be used to drag line work with buckets, brushes, scrapers, swabs or other similar devices. The heavy-duty equipment may be necessary for the removal of roots or heavy debris.
 - 3. Power rodding equipment shall have the capability of spinning the rod either clockwise or counter-clockwise. The equipment shall also be capable of pushing or pulling the rod without rotating the machine.

4. All cleaning equipment, including machines, devices, tools, etc., required for the entire cleaning operations shall be owned or leased and operated by the Contractor. The Contractor shall also submit his equipment list to the Engineer before commencement of the work.
5. The equipment utilized shall be capable of removing all sand, dirt, rocks and other debris, including roots (where ordered by the Engineer), from the drain line to allow adequate internal inspection (in the opinion of the Engineer) of all internal surfaces. The equipment used shall suit the conditions and size of the drain system to be cleaned.
6. All safety precautions outlined in the General Requirements, or required by agencies having jurisdiction, shall be followed by the Contractor during cleaning operations. The cost of such precautions shall be included in the price bid for this item.
7. All precautions shall be taken by the Contractor to protect the storm drain from damage that might result from the use of unsuitable equipment or improper use of approved cleaning equipment. Any drains damaged during the cleaning operations as a result of the Contractor's operations shall be promptly repaired to an acceptable condition (as determined by the Engineer) by and at the expense of the Contractor. If the Contractor's cleaning equipment becomes immobilized within a storm drain, exits the line through broken pipe or portions break off within a storm drain, said equipment shall be retrieved at the Contractor's expense. The Contractor shall act immediately to remedy problems created by the cleaning procedure, which represent a hazard to the general public, such as the collapse of the ground surface above a storm drain. If equipment retrieval necessitates excavation, the Contractor shall be responsible for accomplishing the work at his own expense. Following removal of the equipment, the Contractor shall restore the line and the site in accordance with the construction specifications of the governing body having jurisdiction.

3.4 SITE IMPROVEMENTS

- A. Remove existing above- and below-grade improvements as indicated and as necessary to facilitate new construction.

3.5 DISPOSAL

- A. Disposal: Remove surplus soil material, unsuitable topsoil, obstructions, demolished materials, and waste materials including trash and debris, and legally dispose of them off Owner's property.
 1. Separate recyclable materials produced during site clearing from other non-recyclable materials. Store or stockpile without intermixing with other materials and transport them to recycling facilities.

3.6 LIMITS OF SITE CLEARING

- A. The Contractor shall be fully aware of the limits of Site Clearing based on project plans. In general, the limit of Site Clearing includes all tasks as described above that are required to complete the applicable tasks associated with all works items in the contract.

END OF SECTION

SECTION 312000 - EARTH MOVING

PART 1 GENERAL

1.1 RELATED DOCUMENTS

- A. Drawings and general provisions of the Contract, including General and Supplementary Conditions apply to this Section.
- B. Related Sections include the following:
- C. Division 31 Section 311000 "Site Clearing" for temporary erosion and sedimentation control measures, site stripping, grubbing, stripping and stockpiling topsoil, and removal of above- and below-grade improvements and utilities.

1.2 SUMMARY

- A. This Section includes the following:
 - 1. Excavating and backfilling for site restoration due to the demolition of structures.
 - 2. Subgrade preparation for proposed facilities, and pavements.
 - 3. General site grading.
 - 4. Verification & Disposal Sampling.
 - 5. Disposal of Non-Hazardous Contaminated Soil.

1.3 DEFINITIONS

- A. Backfill: Soil material or controlled low-strength material used to fill an excavation.
- B. Initial Backfill: Backfill placed beside and over pipe in a trench, including haunches to support sides of pipe.
- C. Final Backfill: Backfill placed over initial backfill to fill a trench.
- D. Fill: Soil materials used to raise existing grades.
- E. Structures: Footings, foundations, retaining walls, slabs, tanks, curbs, mechanical and electrical appurtenances, or other man-made stationary features constructed above or below the ground surface.

1.4 PROJECT CONDITIONS

- A. Existing Utilities: Do not interrupt utilities serving facilities occupied by Owner or others unless permitted in writing by Engineer and then only after arranging to provide temporary utility services according to requirements indicated.
- B. Notify Engineer not less than two (2) days in advance of proposed utility interruptions.
- C. Do not proceed with utility interruptions without Engineer's written permission.

- D. Contact New Jersey One Call before excavating.
- E. Demolish and completely remove from site existing underground utilities indicated to be removed. Coordinate with utility companies to shut off services if lines are active.

PART 2 PRODUCTS

2.1 SOIL MATERIALS

- A. General: Provide borrow soil materials when sufficient satisfactory soil materials are not available from excavations.
- B. Satisfactory Soils: ASTM D 2487 Soil Classification Groups GW, GP, GM, SW, SP, and SM, or a combination of these groups; free of rock or gravel larger than three inches (3") in any dimension, debris, waste, frozen materials, vegetation, and other deleterious matter.
- C. Unsatisfactory Soils: Soil Classification Groups GC, SC, CL, ML, OL, CH, MH, OH, and PT according to ASTM D 2487, or a combination of these groups.
- D. Unsatisfactory soils also include satisfactory soils not maintained within two percent (2%) of optimum moisture content at time of compaction.
- E. Sand: ASTM C 33; fine aggregate, natural, or manufactured sand.
- F. Impervious Fill: Clayey gravel and sand mixture capable of compacting to a dense state.
- G. Engineered Fill: Fill that is selected, placed and compacted to an appropriate specification to exhibit the required behavior.

PART 3 EXECUTION

3.1 PREPARATION

- A. Protect structures, utilities, sidewalks, pavements, and other facilities from damage caused by settlement, lateral movement, undermining, washout, and other hazards created by earthwork operations.
- B. Preparation of subgrade for earthwork operations including removal of vegetation, topsoil, debris, obstructions, and deleterious materials from ground surface is specified in Section 311000 "Site Clearing."
- C. Protect and maintain erosion and sedimentation controls, which are specified in Section 311000 "Site Clearing." during earthwork operations.

3.2 DEWATERING

- A. Prevent surface water and ground water from entering excavations, from ponding on prepared subgrades, and from flooding Project site and surrounding area.

- B. Protect subgrades from softening, undermining, washout, and damage by rain or water accumulation.
- C. Reroute surface water runoff away from excavated areas. Do not allow water to accumulate in excavations. Do not use excavated trenches as temporary drainage ditches.
- D. Install a dewatering system to keep subgrades dry and convey ground water away from excavations. Maintain until dewatering is no longer required.

3.3 EXCAVATION, GENERAL

- A. Unclassified Excavation: Excavate to subgrade elevations regardless of the character of surface and subsurface conditions encountered. Unclassified excavated materials may include rock, soil materials, and obstructions. No changes in the Contract Sum or the Contract Time will be authorized for rock excavation or removal of obstructions.
- B. If excavated materials intended for fill and backfill include unsatisfactory soil materials and rock, replace with satisfactory soil materials.
- C. Remove rock to lines and grades indicated to permit installation of permanent construction without exceeding the following dimensions:
 - 1. 24 inches outside of concrete forms other than at footings.
 - 2. Twelve inches (12") outside of concrete forms at footings.
 - 3. Six inches (6") outside of minimum required dimensions of concrete cast against grade.
 - 4. Outside dimensions of concrete walls indicated to be cast against rock without forms or exterior waterproofing treatments.
 - 5. Six inches (6") beneath bottom of concrete slabs on grade.
 - 6. Six inches (6") beneath pipe in trenches, and the greater of 24 inches wider than pipe or 42 inches wide.

3.4 BACKFILL

- A. Place and compact backfill in excavations promptly, but not before completing the following:
 - 1. Construction below finish grade including, where applicable, subdrainage, dampproofing, waterproofing, and perimeter insulation.
 - 2. Surveying locations of underground utilities for Record Documents.
 - 3. Testing and inspecting underground utilities.
 - 4. Removing concrete formwork.
 - 5. Removing trash and debris.
 - 6. Removing temporary shoring and bracing, and sheeting.
 - 7. Installing permanent or temporary horizontal bracing on horizontally supported walls.
 - 8. Place backfill on subgrades free of mud, frost, snow, or ice.

3.5 SOIL FILL

- A. Plow, scarify, bench, or break up sloped surfaces steeper than one (1) vertical to four (4) horizontal so fill material will bond with existing material.
- B. Place and compact fill material in layers to required elevations as follows:
 - 1. Under grass and planted areas, use satisfactory soil material.

2. Under walks and pavements, use screened topsoil at a depth of six inches (6") as defined in the Standards for Soil Erosion and Sediment Control in New Jersey (https://www.state.nj.us/agriculture/divisions/anr/pdf/8_Topsoiling%202011.pdf).
 3. Under steps and ramps, use engineered fill.
 4. Under building slabs, use engineered fill. NJDOT Coarse Aggregate No. 57 or approved equal may be used as a suitable fill material beneath building floor slabs.
 5. Under footings and foundations, use engineered fill.
- C. Place soil fill on subgrades free of mud, frost, snow, or ice. Ensure that subgrade materials are properly compacted prior to placing fill. Test subgrade material for optimum moisture content and compaction in accordance with AASHTO T310 and AASHTO T99.

3.6 COMPACTION OF SOIL BACKFILLS AND FILLS

- A. Place backfill and fill soil materials in layers not more than eight inches (8") in loose depth for material compacted by heavy compaction equipment, and not more than four inches (4") in loose depth for material compacted by hand-operated tampers.
- B. Place backfill and fill soil materials evenly on all sides of structures to required elevations, and uniformly along the full length of each structure.
- C. Compact soil materials to not less than the following percentages of maximum dry unit weight according to AASHTO T 99 and AASHTO T310 and in accordance with the latest edition of the New Jersey Department of Transportation Standard Specifications for Road and Bridge Construction.
1. Under structures, building slabs, steps, and pavements, scarify and recompact top twelve inches (12") of existing subgrade and each layer of backfill or fill soil material at 95 percent.
 2. Under walkways, scarify and recompact top six inches (6") below subgrade and compact each layer of backfill or fill soil material at 95 percent.
 3. Under lawn or unpaved areas, scarify and recompact top six inches (6") below subgrade and compact each layer of backfill or fill soil material at 85 percent.
 4. For utility trenches, compact each layer of initial and final backfill soil material at 85 percent.

3.7 GRADING

- A. General: Uniformly grade areas to a smooth surface, free of irregular surface changes. Comply with compaction requirements and grade to cross sections, lines, and elevations indicated.
1. Provide a smooth transition between adjacent existing grades and new grades.
 2. Cut out soft spots, fill low spots, and trim high spots to comply with required surface tolerances.
- B. Site Grading: Slope grades to direct water away from buildings and to prevent ponding. Finish subgrades to required elevations within the following tolerances:
1. Lawn or Unpaved Areas: Plus or minus 1/2 inch.
 2. Walks: Plus or minus 1/2 inch.
 3. Pavements: Plus or minus 1/2 inch.
- C. Grading inside Building Lines: Finish subgrade to a tolerance of 1/2 inch. when tested with a ten-foot (10') straightedge.

3.8 DISPOSAL OF SURPLUS AND WASTE MATERIALS

- A. Disposal: Remove surplus non-contaminated satisfactory soil and waste material, including unsatisfactory soil, trash, and debris, and legally dispose of it off Owner's property.
 - 1. Remove waste material, including non-contaminated unsatisfactory soil, trash, and debris, and legally dispose of it off Owner's property at the appropriate disposal facility for the waste type involved.
 - 2. Excess clean soil shall be placed on the subject properties as directed by the A/E at an appropriate location. Contractor to provide all equipment, labor and material to grade as needed and stabilize the area in accordance with these specifications and Soil Erosion and Sediment Control standards of New Jersey Latest Edition.

END OF SECTION

SECTION 315000 - EXCAVATION SUPPORT AND PROTECTION

PART 1 GENERAL

1.1 RELATED DOCUMENTS

- A. Drawings and general provisions of the Contract, including Instructions to Bidders, General Conditions, and Supplementary Instructions to Bidders and General Conditions, and other Division 1 Specification Sections, apply to this Section.

1.2 RELATED SECTIONS:

- A. Division 31 Section 312000 "Earth Moving" for excavating, backfilling, site grading, and for site utilities.

1.3 SUMMARY

- A. Section includes temporary excavation support and protection. Any support and protections systems required for the Work are to be included in the various bid items.

1.4 PERFORMANCE REQUIREMENTS

- A. Design, furnish, install, monitor, and maintain excavation support and protection system and permanent sheet piling capable of supporting excavation sidewalls and of resisting soil and hydrostatic pressure and superimposed and construction and permanent loads as necessary to complete the work.
 - 1. Delegated Design: Design excavation support and protection system, including comprehensive engineering analysis by a qualified professional engineer, using performance requirements and design criteria indicated.
 - 2. Prevent surface water from entering excavations by grading, dikes, or other means.
 - 3. Install excavation support and protection systems and permanent steel sheet piling without damaging existing buildings, structures, and site improvements adjacent to excavation.
 - 4. Monitor vibrations, settlements, and movements.

1.5 SUBMITTALS

- A. Shop Drawings: For excavation support and protection system and permanent steel sheet piling.
- B. Other Informational Submittals:
 - 1. Photographs: Show existing conditions of adjacent construction and site improvements that might be misconstrued as damage caused by the absence of, the installation of, or the performance of excavation support and protection systems and permanent steel sheet piling. Submit before Work begins.
 - 2. Record Drawings: Identifying and locating capped utilities and other subsurface structural, electrical, or mechanical conditions.

1.6 QUALITY ASSURANCE

- A. Pre-installation Conference: Conduct conference at Project site.
 - 1. Review methods and procedures related to excavation support and protection including, but not limited to, the following:
 - a. Existing utilities and subsurface conditions.
 - b. Proposed excavations.
 - c. Proposed equipment.
 - d. Working area location and stability.

1.7 PROJECT CONDITIONS

- A. Interruption of Existing Utilities: Do not interrupt any utility serving facilities occupied by Owner or others unless permitted under the following conditions and then only after arranging to provide temporary utility according to requirements indicated:
 - 1. Notify Engineer no fewer than two (2) days in advance of proposed interruption of utility.
 - 2. Do not proceed with interruption of utility without Engineer's written permission.
- B. Survey Work: Engage a qualified land surveyor to survey adjacent existing buildings, structures, and site improvements; establish exact elevations at fixed points to act as benchmarks. Clearly identify benchmarks and record existing elevations.
 - 1. During installation of excavation support and protection systems, regularly resurvey benchmarks, maintaining an accurate log of surveyed elevations and positions for comparison with original elevations and positions. Promptly notify Engineer if changes in elevations or positions occur or if cracks, sags, or other damage is evident in adjacent construction.

PART 2 PRODUCTS – NOT USED

PART 3 EXECUTION

3.1 PREPARATION

- A. Protect structures, utilities, sidewalks, pavements, and other facilities from damage caused by settlement, lateral movement, undermining, washout, and other hazards that could develop during excavation support and protection system and permanent steel sheet pile operations.
 - 1. Shore, support, and protect utilities encountered.

3.2 SAFETY PROCEDURES

- A. Follow safety procedures according to the latest OSHA regulations.

END OF SECTION

SECTION 321823 – ELASTIC LAYER SYSTEM

PART 1 GENERAL

1.1 DESCRIPTION OF REQUIREMENTS

- A. This work shall include the complete removal and disposal of the existing e-layer, finish stone, base stone, filter fabric and panel piping; preparation of the existing subsurface, as necessary; installation of new e-layer, finish stone, base stone, filter fabric and panel piping as specified. Coordination with the existing awarded turf installation contractor will be required to ensure the e-layer is approved for turf installation and that it meets FIH requirements. This work shall consist of all labor, materials, tools and equipment necessary to install and place all finish stone, base stone, panel piping, e-layer, and related infrastructure and hardware as indicated on the plans and as specified herein.
- B. The installation of all new materials shall be performed in strict accordance with these specifications, ASTM, the manufacturers written installation instructions, and in accordance with all approved details and shop drawings. The installation of finish stone, base stone, filter fabric, panel piping, and e-layer shall comply with FIH requirements, so that the College possesses an FIH warranted field at the end of construction.
- C. Contractor to provide shop drawing submittal with all materials and layouts to the Owner and the Engineer prior to installation of all products. Contractor to remove and legally dispose off-site of the existing e-layer, flat panel piping, filter fabric, base stone, and finish stone. The existing perimeter pipe will be reused if determined to be acceptable to the College and the College Engineer.
- D. After the installation of finish stone and base stone, Contractor to have third party perform infiltration tests and submit report to the College and College's Engineer for approval of porosity rates prior to installation of the e-layer. After the installation of the e-layer, contractor to have third party perform infiltration tests and submit a report to the College and College's Engineer for approval of porosity rates.

1.2 RELATED DOCUMENTS

- A. Drawings and general provisions of the Contract, including General and Supplementary Conditions and Division 01 Specification Sections, apply to this Section.

1.3 SUBMITTALS

- A. Resume of the Project Manager and E-layer Foreman that will be utilized for the project.
- B. A list of five (5) references for same scope of services provided to colleges or professional sports organizations in the last two (2) years to include:
 - 1. Name of Client; Contact Person; Telephone Number and/or email address.
 - 2. Project scope for each reference.
- C. Vendor must list any contract disputes and provide explanation.
- D. Vendor must list any involvement with current litigation.
- E. Product Data: For each type of product indicated.

- F. Shop Drawings: Show fabrication and installation details for e-layer. Include plans, elevations, sections and details.
- G. Manufacturer Certificates: Must have been in business for at least ten (10) years, actively selling, installing and maintaining e-layers. Site superintendent shall have at least ten (10) installations similar to this type. Certified list of ten (10) existing installations of the e-layer system that is specified for this project within the last ten (10) years at college-level or higher fields, including Owner representative and telephone number, attesting compliance with quality assurance information. All must be located in the continental United States and at least two (2) FIH field hockey fields in the past ten (10) years.
- H. Installer Qualifications:
 - 1. Be competent and established in installation of specified materials.
 - 2. Laser guided finishing grade equipment.
 - 3. Use only trained technicians working under the direct supervision of approved installer supervisors for the installation of the e-layer.
 - 4. The installation team shall be trained and certified, in writing, by the e-layer manufacturer, as competent in the installation of the specified material.
- I. Product Data: Product data sheets (PDS) for proposed e-layer product with relative characteristics and all associated details must be provided. Submit manufacturer's catalog cuts, material safety data sheets (MSDS), brochures, specifications, preparation and installation instructions and recommendations.
- J. All supplied and installed materials and products must meet or exceed the minimum specifications designated in this section. Sufficient data must be submitted to indicate compliance with the Contract Documents.
- K. Prior to completion of this project, all Mandatory Testing Documents for the actual products, conducted by a third-party laboratory, as required and listed in this document will need to be approved by the Owner and the Engineer.
- L. Submit a copy of the E-Layer System Providers installation standards.
- M. Sample Warranty: Provide a sample warranty conforming to all requirements as set forth in warranty section of this specification with the bid. Policy must be in force at time of bid.
- N. Warranties: The Contractor shall provide a warranty to the Owner that covers defects in materials and workmanship of the e-layer for a period of twenty (20) years from the date of substantial completion. The e-layer manufacturer must verify that their representative has inspected the installation and that the work conforms to the manufacturer's requirements. The warranty shall specifically exclude vandalism and acts of God beyond the control of the Owner or the manufacturer. The Contractor shall provide a warranty to the Owner that covers defects in the installation workmanship, and further warrant that the e-layer will not degrade under normal use as an underlayment for artificial turf sports surfaces and will be a part of a turf system that will not exceed a field average GMAX of 200 as tested in accordance with ASTM 1936 Protocol using the F-335-A missile with test conditions above 40 degrees F and free of any frost or contaminants, provided that the original turf initially installed over the e-layer has never been replaced.
- O. Schedule: Include proposed project timeline for the project.

1.4 PRE-CONSTRUCTION SUBMITTAL REQUIREMENTS:

- A. Shop Drawings: Prior to ordering materials and within fourteen (14) calendar days after issuances of Notice to Proceed, submit Shop Drawings showing all component parts of the e-layer system and installation requirements.

1.5 QUALITY ASSURANCE

- A. Installer Qualifications: An authorized representative of e-layer manufacturer for installation and maintenance of units required for this Project.
- B. Keep e-layer perfectly clean throughout the installation.
- C. Source Limitations: Obtain e-layer through one (1) source from a single manufacturer.
- D. Preinstallation Conference: Conduct conference at Project site.
- E. All components and their installation method shall be designed and manufactured for use under outdoor athletic fields. The materials as hereinafter specified, should be able to withstand full climatic exposure in the Northeast USA, be resistant to insect infestation, rot, fungus and mildew; to heat degradation, and shall have the basic characteristic of flow through-drainage allowing free movement of surface run-off through the e-layer and directly into the prepared granular base and into the field drainage system.
- F. The e-layer and components shall be of national reputation with previous use at all levels of competition, including professional and collegiate levels of Field Hockey and Lacrosse. The e-layer shall be produced by the manufacturer and installed by factory-authorized distributors directly employing the installation crew. Manufacturing "jobbers" or installation "subcontractors" shall not be permitted.
- G. Prior to the bid and/or Landscape Architect/Engineer approval of a specified e-layer system, the company and manufacturer (if different than company) shall specify in writing that their e-layer system does not violate any other manufacturers patents, patents allowed or patents pending.
- H. Prior to the beginning of installation, the manufacturer/ installer of the e-layer shall prepare the subbase and supply a Certificate of Subbase Acceptance for the purpose of obtaining manufacturer's warranty for the finished synthetic playing surface.
- I. Weather Limitations: Proceed with installation only when existing and forecasted weather conditions permit e-layer to be installed according to manufacturers' written instructions and warranty requirements.
- J. Field Measurements: Indicate measurements on Shop Drawings and all submittals prior to installation. All Field measurements and layout shall conform to NCAA and FIH Standards. E-layer Installer to verify all measurements prior to construction.

1.6 PROJECT CONDITIONS

- A. The following Project Conditions must be followed:
 - 1. Existing Utilities: Do not interrupt utilities serving facilities occupied by College or others unless permitted in writing by College, and then, only after arranging to provide temporary utility services according to requirements indicated below:

- a. Notify College at least two (2) days in advance of proposed utility interruption.
- b. Field Measurements: Verify actual layout and field measurements.
- c. Contractor shall be responsible for the following:
 - 1) Protect existing construction and restore damaged areas, post construction, to include landscaping.
 - 2) Site safety will require signage for public protection and warning for construction area.
 - 3) The manufacturer shall have a representative on site and submit a written report to certify the installation and warranty compliance.

B. The following Warranties must be provided:

1. The Contractor shall provide a warranty to the Owner that covers defects in materials and workmanship of the e-layer for a period of twenty (20) years from the date of substantial completion. The e-layer manufacturer must verify that their representative has inspected the installation and that the work conforms to the manufacturer's requirements. The warranty shall specifically exclude vandalism and acts of God beyond the control of the Owner or the manufacturer. The Contractor shall provide a warranty to the Owner that covers defects in the installation workmanship, and further warrant that the e-layer will not degrade under normal use as an underlayment for artificial turf sports surfaces and will be a part of a turf system that will not exceed a field average GMAX of 200 as tested in accordance with ASTM 1936 Protocol using the F-335-A missile with test conditions above 40 degrees F and free of any frost or contaminants, provided that the original turf initially installed over the e-layer has never been replaced.

C. Other items that must be addressed include the following:

1. Contractor warrants to the College that the permeable synthetic system shall drain vertically a minimum of 20 inches precipitation per hour without visible surface ponding.
2. The Contractor shall complete all repairs within 72 hours of written notification by the College.
3. In the event the Contractor does not respond to the College's written notice within 72 hours of receipt of notice or does not submit, schedule and execute corrective work within seven (7) days, the College has the option of having the work performed at the expense of the Contractor without impact or affect to the warranty.
4. All e-layer warranties shall be non-prorated and limited to repair or replacement of the affected areas and shall include all necessary materials, labor and transportation cost to complete the repairs. Warranties that include language which pro-rates benefits shall cause the provider's bid to be rejected.
5. The field shall be tested each year during the life of the warranty after installation by an independent firm at the contractor's cost.
6. Warranty Period: Twenty (20) years from date of Substantial Completion and Acceptance by Owner.

PART 2 PRODUCTS

2.1 SYNTHETIC TURF SYSTEM

- A. The synthetic turf system for a collegiate field hockey and lacrosse field shall be provided and installed by others. Contractor to coordinate the installation of e-layer with the turf contractor. The turf system and e-layer shall be FIH certified.

2.2 E-LAYER

- A. Shall be a 26mm nominal thickness poured e-layer that is energy absorbing composed of shredded SBR rubber, mineral aggregate and moisture cured polyurethane binder. The system shall have demonstrated resistance to rot, mildew, water, freeze-thaw and compression set associated with normal athletic field use.
- B. The e-layer shall be composed of the following:
 - 1. 45% by weight 1mm to 5 mm SBR rubber granules,
 - 2. 45% by weight ¼” aggregate and
 - 3. 10% by weight methylenediphenyl diisocyanate (MDI) polyurethane binder.
- C. The e-layer shall weigh approximately 54 lbs./sq. yd.
- D. In order to meet FIH certification standards, the e-layer shall comply with the following test standards:

| <u>Property</u> | <u>Test Method</u> | <u>Permitted Tolerance</u> |
|--------------------|-------------------------------------|---|
| Thickness | EN 1969 | ➤ Or equal to 90% of manufacturer’s declaration |
| Mass per unit area | ISO 8543 | Less than or equal to 10% |
| Shock absorption | EN 14808 | Less than or equal to 5% force reduction |
| Tensile strength | EN 12230 | Greater than or equal to 0.15 MPa |
| Composition | Photographic record and description | Same composition |

2.3 BASE AND FINISHING STONE

- A. The following items, or approved equal, shall be installed if required:
 - 1. Base and Finishing Stone:

| <u>Sieves</u> | <u>%PASSING</u> | |
|------------------|-------------------|------------------------|
| | <u>Base Stone</u> | <u>Finishing Stone</u> |
| 3” or 75mm | | |
| 2” or 50mm | | |
| 1½” or 38mm | | |
| 1” or 25mm | 100 | |
| ¾ or 19mm | 90-100 | |
| ½” or 12.5mm | 80-100 | 100 |
| 3/8” or 9.5mm | 70-100 | 85-100 |
| ¼” or 6.3mm | 60-90 | 75-100 |
| US #4 or 4.75mm | 50-85 | 60-90 |
| US #8 or 2.36mm | 30-65 | 35-75 |
| US #16 or 1.18mm | 10-50 | 10-55 |
| US #30 or 600mm | 0-35 | 0-40 |
| US #60 or 250mm | 0-15 | 0-15 |

| | | |
|------------------|-----|-----|
| US #100 or 150mm | 0-8 | 0-8 |
| US #200 or 75mm | 0-2 | 0-2 |

RESTRICTIONS:

To ensure structural stability: $D_{60}/D_{10} > 5$ and $1 < \frac{D_{30}^2}{D_{10} D_{60}} < 3$
Fragmentation must be 100%.

To ensure separation of both stones: $\frac{D_{85} \text{ of finishing stone}}{D_{15} \text{ of base stone}} > 2$

and $3 < \frac{D_{50} \text{ of base stone}}{D_{50} \text{ of finishing stone}} < 6$

To ensure proper drainage:

Permeability of base stone > 50 in/hr (3.5×10^{-2} cm/sec)

Permeability of finishing stone > 10 in/hr (7.0×10^{-3} cm/sec)

Porosity of both stones $> 25\%$ (When stone is saturated and compacted to 95% Proctor.)

2. Filter Fabric: The contractor shall install Mirafi 140N or approved equal as shown on the construction plans,

PART 3 EXECUTION

3.1 EXAMINATION

- A. The base stone, finish stone and e-layer system shall be installed in the location as shown on the plans, and in accordance with the manufacturer's requirements. The Contractor shall be responsible for protection of all e-layer surfaces until final acceptance by the Owner. All manufacturer guarantees shall be given to the Owner.
- B. Examine substrates and conditions, with Installer present, for compliance with requirements for maximum moisture content, installation tolerances, and other conditions affecting performance of work.
- C. Proceed with installation of the base stone, finish stone and e-layer only after unsatisfactory conditions have been corrected.

3.2 PREPARATION

- A. Preparation of Subgrade: All existing e-layer, finish and base stone, filter fabric, organic and non-compactable materials MUST be removed.
- B. Contractor shall provide protection of existing site features from construction activities. Any damage as a result of contractor's actions shall become the full responsibility of the contractor.
- C. Site protection includes, but is not limited to, security guards, video surveillance, and security barriers at the discretion of the Contractor. Damage, vandalism and/or loss during the construction period shall be the responsibility, including financial, of the Contractor. The Contractor is advised to ensure they

have appropriate insurance coverage for these types of liabilities and take all precautions to eliminate the risk.

- D. Fence Removal: Coordinate with College if fencing is required to be removed for equipment access to work areas. Fencing shall be removed and reinstalled in original condition by contractor.
- E. Staging, Parking and Site Access: Contractor shall coordinate with College.
- F. Contractor shall obtain and pay for any required permits related to delivery of materials.
- G. The Contractor is responsible to maintain the entire job site at all times, including all workers and visitors, in a safe and professional environment.
- H. Contractor is solely responsible for all health and safety requirements, including but not limited to prevention, personnel training and the posting of signs and notices.

3.3 DEMOLITION

- A. Site access and Temporary Controls: Conduct selective demolition and debris removal operations to ensure minimum interference with roads, streets, walks, walkways and other adjacent occupied facilities.
- B. Temporary Facilities: Provide temporary barricades and other protection required to prevent injury to people and damage to adjacent buildings and facilities to remain.
- C. General: Demolish and remove existing construction only to the extent required by new construction as stated.
- D. General: Except for items or materials indicated to be reused or otherwise stated to remain, all items to be removed shall be disposed of properly off-site by the Contractor.
- E. College's property: Contractor shall remove demolished materials from Project site and legally dispose.
- F. E-Layer: Conduct demolition of existing e-layer, finish stone, base stone, filter fabric and panel piping in a careful manner to maintain the integrity of the existing base.
- G. Perimeter Access: Protect surfaces where construction vehicles will be crossing to maintain integrity and appearance.

3.4 INSTALLATION

- A. Underdrain System: Complete a video inspection of the perimeter pipe to determine if any repairs or replacement of the pipe is required. Install or repair as determined based on subsurface inspection and as directed by the Engineer. All costs for the repair of the perimeter pipe, if necessary, will be included as part of the allowance item in the bid summary. Once any repairs to the perimeter pipe are known, the Contractor shall complete the repair or replacement work necessary. Should no repairs or replacement of the perimeter pipe be required, the item will not be used.
- B. Base Stone
 - 1. A geotextile filter fabric is required to cover the soil bed. Install filter fabric with overlapping seams as specified by the manufacturer and as directed by the Engineer.

2. Subgrade must meet the compaction requirements of 95% standard proctor set forth herein with third party verification prior to installation of fabric, stone and drainage.
3. The base stone must be laid without damaging the soil bed, geotextile liner or drains. It is very important to not create any depressions with heavy equipment. The specified stone or aggregate supplied must conform to the recommended specifications. The finished crushed stone or aggregate base supplied must be stable and permeable.
4. If the required compacted depth of the base course exceeds six inches (6"), the base shall be constructed in two (2) or more layers or lifts of approximate equal thickness. Each layer must be compacted in both directions to attain the specified compaction rate.
5. The base course must be sloped as specified. The minimum slope and direction shall be as depicted on the contract documents and as directed by the Engineer.
6. The grade of the base course shall not vary from the specified grade by more than 1/2 inch from design grade.
7. The base course must be compacted in both directions to attain the specified compaction rate of 95% standard Proctor. **Verification to be provided by Contractor.**

C. Finishing Stone

1. The final grade aggregate layer should NOT BE MORE than one-inch (1") deep and NOT LESS THAN ¼ inch deep. Depth of Finishing Stone is to be included in the overall depth of the base stone.
2. The final grade material must be sloped as specified. The minimum slope and direction shall be as depicted on the contract documents and as directed by the Engineer.
3. The final grade must be compacted in both directions to attain the specified compaction rate of 95% standard Proctor.
4. The final grade of the finishing stone shall not vary from the specified grade by more than ½ inch from design grade, nor by more than ¼ inch in ten feet (10'). Laser guided grading is highly recommended.
5. The Contractor shall retain the services of an independent contractor to complete percolation testing of the compacted base stone layer to ensure the proper permeability rates as noted in Section 2.3 of this specification.

D. E-Layer

1. Materials shall be approved by the manufacturer, Owner and Engineer and installed in accordance with the manufacturer's standard procedures and approved shop drawings.
2. All designs, layouts and materials shall conform to all current applicable standards that may apply to this type of e-layer installation.
3. The base shall be as-built by the Contractor by means of a laser level with a minimum of 500 shots. The as-built shall be reviewed by the Engineer. The Contractor shall fine grade the base suitably including properly rolling and compacting. The base must be approved prior to the start of e-layer installation.
4. The project superintendent shall thoroughly inspect all material delivered to the site both for quality and quantity to ensure that the entire installation shall have sufficient material to maintain proper mixing ratios.
5. The installation shall be performed in full compliance with approved shop drawings. Only factory-trained technicians skilled in the installation of athletic caliber e-layer systems, working under the direct supervision of the manufacturer's supervisors, shall undertake the placement of the system. The designated supervisory personnel on the project must be certified, in writing by the e-layer manufacturer, as competent in the installation of this material. The manufacturer shall certify the installation and warranty compliance.
6. The e-layer shall be constructed in one lift. The lift shall be laid running the length of the field. All joints shall be troweled with compactions by a paving machine as the material is paved. All

seams shall be hand rolled. Cold pad joints and areas such as concrete curbing on which material lays or abuts shall be primed with a polyurethane primer supplied by the binder manufacturer.

7. The e-layer shall be allowed to cure for 48 hours prior to the installation of the synthetic turf system.
8. The e-layer shall be inspected and certified by the manufacturer and the synthetic turf installer as ready for the installation of the synthetic turf system and must be perfectly clean as installation commences and shall be maintained in that condition throughout the process.
9. The Contractor shall retain the services of an independent contractor to complete percolation testing of the e-layer to ensure the proper permeability rates are maintained.

3.5 FIELD QUALITY CONTROL

- A. Testing Agency: The Contractor is responsible to engage a qualified independent testing and inspecting agency to perform field tests and inspections and prepare test reports. Test reports shall be provided to the Engineer/Landscape Architect and Owner for review during the Construction phase. All testing shall be performed at the Contractor's expense with no additional costs to the Owner.
- B. Testing Services: Testing and inspecting of completed applications of e-layer system shall take place in successive stages, in areas of extent and using methods as follows. Do not proceed with application of the next stage until test results for previously completed applications show compliance with requirements. All testing shall be performed at the Contractor's expense with no additional costs to the Owner.
- C. The Contractor shall remove and replace applications where test results indicate that it does not comply with specified requirements. All replacements shall be at Contractor's expense with no additional costs to the Owner.
- D. Arrange for surfacing manufacturer's technical personnel to inspect surfacing and components during installation and at final completion to verify compliance with manufacturer's specifications and project requirements.
- E. Notify College at least 48 hours in advance of date and time of final inspection.

3.6 FINAL ACCEPTANCE

- A. Prior to Final Acceptance, the Contractor shall submit to the Owner three (3) copies of the product warranty.
- B. Project Record Documents: Record actual locations of drains or other pertinent information.

3.7 INSPECTION AND APPROVAL

- A. The College has the right to reject, or require corrections to the materials or workmanship, which in the College's opinion, fails to meet specifications. Any rejected or fault work shall be repaired at no cost to the College.
- B. All e-layer materials shall be tested post-installation. The install shall include G-Max testing on the installed surface prior to acceptance and be at the contractor's expense. Testing shall comply with ASTM F-355 Procedure A by an independent materials testing laboratory.

END OF SECTION

SECTION 330130.11 - TELEVISION INSPECTION OF PIPES

PART 1 GENERAL

1.1 SUMMARY

A. Section Includes:

1. Pipeline flushing and cleaning.
2. Television inspection of pipelines.
3. Audio-video recording of pipeline interior.

1.2 UNIT PRICE - MEASUREMENT AND PAYMENT

A. Television Inspection of Pipe:

1. Basis of Measurement: By lump sum.
2. Basis of Payment: Includes pipeline flushing and cleaning, television inspection, and audio-video recording of pipeline.

1.3 COORDINATION

- A. Coordinate Work of this Section with College and College's Engineer.

1.4 PREINSTALLATION MEETINGS

- A. Convene minimum one (1) week prior to commencing Work of this Section.

1.5 SEQUENCING

A. Sequence Work in following order:

1. Pipeline flushing and cleaning.
2. Television inspection of pipelines.
3. Provide College and College's Engineer with the findings.

1.6 SUBMITTALS

A. DVDs:

1. Submit two (2) copies of completed narrated color DVDs to College and one (1) copy of completed narrated color DVDs to the College's Engineer. Copies to be identified by Project name.
2. DVDs become property of College and College's Engineer.

B. Inspection Logs:

1. Submit cleaning and television inspection logs for each section of pipe to be verified.
2. Include following minimum information:

- a. Stationing and location of lateral services, wyes, or tees.
- b. Date and clock time references.
- c. Pipe joints.
- d. Infiltration/inflow defects.
- e. Cracks.
- f. Leaks.
- g. Offset joints.

1.7 QUALIFICATIONS

- A. Applicator: Company specializing in performing Work of this Section with minimum three (3) years' documented experience.

PART 2 PRODUCTS

2.1 DVDs

- A. Description: Digital video formatted discs.
- B. Audio track containing simultaneously recorded narrative commentary and evaluations of videographer, describing in detail condition of pipeline interior.

PART 3 EXECUTION

3.1 EXAMINATION

- A. Verify location of pipelines to be inspected.

3.2 PREPARATION

- A. Flush and clean pipeline to remove sludge, dirt, sand, stone, grease, and other materials to ensure clear view of interior conditions.
- B. Debris:
 1. Intercept flushed debris at next downstream manhole using weir or screening device.
 2. Remove and dispose of debris off Site.

3.3 APPLICATION

- A. Closed-Circuit Television (CCTV) Camera System:
 1. Use cameras specifically designed and constructed for closed-circuit stormwater pipe inspection.
 2. Use camera equipment with pan-and-tilt capability to view each lateral connection at multiple angles.
 3. Use camera capable of moving both upstream and downstream with minimum 1,000 feet horizontal distance within one setup and using direct-reading cable position meter.

3.4 FIELD QUALITY CONTROL

A. Pipeline Inspection:

1. Audio-video record sections of stormwater pipeline around the athletic field.
2. Identify and record locations of flat grades, dips, deflected joints, open joints, broken pipe, protrusions into pipeline, and points of infiltration.
3. Locate and record service connections.
4. Record locations of pipeline defects, connection horizontal distance in feet, and direction from inlet.
5. Video-record with pipe section plugged to view 100 percent of pipe ID.
6. Use flow-control methods as specified for bypass pumping system to eliminate surcharging and to reduce flow.

END OF SECTION

SECTION 334100 - STORM UTILITY DRAINAGE PIPING

PART 1 GENERAL

1.1 SUMMARY

- A. The work shall include the installation of proposed drainage panel piping as depicted on the plans as well as repairing or replacing the existing eight inch (8") perimeter pipe (if and where directed) if it is deemed inadequate after review of the video inspection.
- B. At inlets/manholes that intersect existing drainage pipe, the contractor shall replace pipe sections as necessary while maintaining the existing pipe inverts for proper connection. The Contractor shall replace piping and make connections as needed to connect the existing piping to the inlet and manholes.
- C. The contractor shall verify all the invert elevations of pipes proposed for modification in this contract prior to installing any drainage materials. Any discrepancies shall be submitted to the Engineer for review.
- D. Prior to installation of any storm drainage system components the Contractor shall be responsible for the cleaning of all existing storm structures and piping on the project site in accordance with Division 33 Section 330130.11, "Television Inspection of Pipes".

1.2 SUBMITTALS

- A. Product Data: For the following:
 - 1. Special pipe fittings.
 - 2. 8" perforated N-12 perimeter pipe to match existing
 - 3. 1"x12" panel drain.

1.3 DELIVERY, STORAGE, AND HANDLING

- A. Do not store plastic pipe and fittings in direct sunlight.
- B. Protect pipe, pipe fittings, and seals from dirt and damage.

1.4 PROJECT CONDITIONS

- A. Interruption of Existing Storm Drainage Service: Do not interrupt service to facilities occupied by Owner or others unless permitted under the following conditions and then only after arranging to provide temporary service according to requirements indicated:
 - 1. Notify Engineer no fewer than two (2) days in advance of proposed interruption of service.
 - 2. Do not proceed with interruption of service without Engineer's written permission.

PART 2 PRODUCTS

2.1 MATERIALS

- A. 8" HDPE perimeter pipe shall be perforated N-12 dual wall pipe as manufactured by ADS or approved equal.
- B. One-inch by twelve-inch (1"x12") Panel Pipe shall be AdvanEdge as manufactured by ADS or approved equal.

PART 3 EXECUTION

3.1 EARTHWORK

- A. Excavation, trenching, and backfilling are specified in Division 31 Section 312000 "Earth Moving."

3.2 PREPARATION

- A. Provide protection to all prepared grades and/or turf areas
- B. Verify all grades prior to commencement

3.3 PIPING INSTALLATION - GENERAL

- A. General Locations and Arrangements: Drawing plans and details indicate general location and arrangement of underground storm drainage piping. Location and arrangement of piping layout take design considerations into account. Install piping as indicated, to extent practical. Where specific installation is not indicated, follow piping manufacturer's written instructions.
- B. Install piping beginning at low point, true to grades and alignment indicated with unbroken continuity of invert. Place bell ends of piping facing upstream. Install gaskets, seals, sleeves, and couplings according to manufacturer's written instructions for use of lubricants, cements, and other installation requirements.
- C. Install proper size increasers, reducers, and couplings where different sizes or materials of pipes and fittings are connected. Reducing size of piping in direction of flow is prohibited.

3.4 CLOSING ABANDONED STORM DRAINAGE SYSTEMS

- A. Abandoned Piping: Close open ends of abandoned underground piping indicated to remain in place. Include closures strong enough to withstand hydrostatic and earth pressures that may result after ends of abandoned piping have been closed. Use either procedure below:
 - 1. Close open ends of piping with at least eight-inch (8") thick, brick masonry bulkheads.
 - 2. Close open ends of piping with threaded metal caps, plastic plugs, or other acceptable methods suitable for size and type of material being closed. Do not use wood plugs.

- B. Abandoned Manholes and Structures: Excavate around manholes and structures as required and use one procedure below:
 - 1. Remove manhole or structure and close open ends of remaining piping.
 - 2. Remove top of manhole or structure down to at least 36" below final grade. Fill to within twelve inches (12") of top with stone, rubble, gravel, or compacted dirt. Fill to top with concrete.
- C. Backfill to grade according to Division 31 Section 2000 "Earth Moving."

3.5 FIELD QUALITY CONTROL

- A. Inspect interior of piping to determine whether line displacement or other damage has occurred. Inspect after approximately 24 inches (609.6 mm) of backfill is in place, and again at completion of Project.
 - 1. Submit separate reports for each system inspection.
 - 2. Defects requiring correction include the following:
 - a. Alignment: Less than full diameter of inside of pipe is visible between structures.
 - b. Deflection: Flexible piping with deflection that prevents passage of ball or cylinder of size not less than 92.5% of piping diameter.
 - c. Crushed, broken, cracked, or otherwise damaged piping.
 - d. Infiltration: Water leakage into piping.
 - e. Exfiltration: Water leakage from or around piping.
 - 3. Replace defective piping using new materials and repeat inspections until defects are within allowances specified.
 - 4. Reinspect and repeat procedure until results are satisfactory.
- B. Test new piping systems, and parts of existing systems that have been altered, extended, or repaired, for leaks and defects.
 - 1. Do not enclose, cover, or put into service before inspection and approval.
 - 2. Test completed piping systems according to authorities having jurisdiction.
 - 3. Schedule tests and inspections by authorities having jurisdiction with at least 24-hour advance notice.
 - 4. Submit separate report for each test.
 - 5. Gravity-Flow Storm Drainage Piping: Test according to requirements of authorities having jurisdiction, UNI-B-6, and the following:
 - a. Exception: Piping with soil tight joints unless req. by authorities having jurisdiction.
 - b. Option: Test plastic piping according to ASTM F 1417.
- C. Leaks and loss in test pressure constitute defects that must be repaired.
- D. Replace leaking piping using new materials/repeat testing until leakage is within allowances specified.

3.6 CLEANING

- A. Clean interior of piping of dirt and superfluous materials. Flush with potable water.

END OF SECTION

Attachment A

INFILTRATION TEST REPORT



TESTING TECHNOLOGY FOR SPORT

DETERMINATION OF WATER INFILTRATION RATE

BS EN 12616:2013

| | | | |
|--|---|--------------------|------------|
| Report Number | 91282/1417 | Report Date | 06/25/2020 |
| Project Name | The College of New Jersey | Test Date | 06/21/2020 |
| Client Information | AstroTurf | | |
| Site Address | 7689+5W Ewing Township, New Jersey 08628 | | |
| Prepared by | Mark Korvas | | |
| Checked by | Kieran O'Donnell | | |
| <p><i>Sports Labs reports and data are for the exclusive use of the customers who they are addressed to and may not be reproduced without permission from Sports Labs.</i></p> | | | |

INTRODUCTION

On-site water permeability testing was carried out in accordance with BS EN 121616:2013.

TEST METHOD

ASTM 12616:2013: Surfaces for sports areas – Determination of water infiltration rate

SITE PHOTO



RESULTS SUMMARY

| Test Location | 1 | 2 | 3 | 3* | 4 | 5 | 6 | 7 | 8 | 9 |
|-----------------|---|---|---|----|----|---|---|---|---|---|
| Inches per hour | 2 | 2 | 4 | 4 | 11 | 9 | 9 | 2 | 2 | 8 |



UNITED STATES
 4295 Cromwell Road, Suite 204
 Chattanooga, Tennessee 37421
 Phone: 1-423-541-5526
 Email: support@sportslabs.com
 Web: www.sportslabs.com

REGIONAL LOCATIONS

- Seattle, Washington
- Columbia, Missouri
- Dallas, Texas
- Orlando, Florida
- Providence, Rhode Island



TESTING TECHNOLOGY FOR SPORT

DETERMINATION OF WATER INFILTRATION RATE

BS EN 12616:2013

| SITE AND TEST INFORMATION | | | |
|---------------------------|---------------|--------------|---------------------------|
| 12616 Method | A | Device | Double Ring Infiltrometer |
| Surface Cond. | Wet | Carpet Type | N/A |
| Ambient Air Temp. (F) | 91 – 92 | Infill Type | N/A |
| Surface Temp. (F) | 85 | Underlayment | None |
| Water Temp. (F) | 63 | Sub-Base | Compacted Aggregate |
| Method of Sealing | Weight / Tamp | | |
| Notes | None | | |

RESULTS TABLE

| | Test Location | | | | | | | | | |
|-------------------------|---------------|-------|-------|-------|-------|-------|-------|-------|-------|-------|
| | 1 | 2 | 3 | 3* | 4 | 5 | 6 | 7 | 8 | 9 |
| Maximum Fall Time (sec) | 1200 | 994 | 600 | 534 | 201 | 258 | 248 | 1054 | 1200 | 285 |
| Temp. Correction | 0.814 | 0.814 | 0.814 | 0.814 | 0.814 | 0.814 | 0.814 | 0.814 | 0.814 | 0.814 |
| Porosity in / hr | 2 | 2 | 4 | 4 | 11 | 9 | 9 | 2 | 2 | 8 |

< East West >



UNITED STATES
 4295 Cromwell Road, Suite 204
 Chattanooga, Tennessee 37421
 Phone: 1-423-541-5526
 Email: support@sportslabs.com
 Web: www.sportslabs.com

REGIONAL LOCATIONS

- Seattle, Washington
- Columbia, Missouri
- Dallas, Texas
- Orlando, Florida
- Providence, Rhode Island

DETERMINATION OF WATER INFILTRATION RATE

BS EN 12616:2013

Sight Photos



End of Report



UNITED STATES
 4295 Cromwell Road, Suite 204
 Chattanooga, Tennessee 37421
 Phone: 1-423-541-5526
 Email: support@sportslabs.com
 Web: www.sportslabs.com

REGIONAL LOCATIONS

- Seattle, Washington
- Columbia, Missouri
- Dallas, Texas
- Orlando, Florida
- Providence, Rhode Island

Attachment B

PRE-CONSTRUCTION UTILITY SURVEY



SUBMITTAL

| | |
|-----------------------|----------------------------|
| Date: _____ | Submitted by: _____ |
| Project: _____ | |

| | |
|-------------------------------|----------------------------------|
| Submittal No: _____ | Copies: <u>Electronic</u> |
| Specification Section: | _____ |
| Item: | _____ |
| Section #: | _____ |

| | |
|-----------------------|-------|
| Manufacturer: | _____ |
| Supplier: | _____ |
| Subcontractor: | _____ |

| | |
|---|--------------------|
| <input type="checkbox"/> Approved as submitted | _____ |
| | (Signature & Date) |
| <input type="checkbox"/> Approved as noted | _____ |
| | (Signature & Date) |
| <input type="checkbox"/> Rejected, Revise & Resubmit | _____ |
| | (Signature & Date) |
| Comments: | _____ |



**SUBSURFACE
SCANNING
SOLUTIONS**

Subsurface Investigation to Locate Underground Utilities

Prepared For: AstroTurf

Prepared By:
Steve Logue
Project Manager-Philadelphia, PA
6 May 2020



6 May 2020
AstroTurf
Attn: Christian Dennaë
Site: 2000 Pennington Rd, Ewing, NJ

We appreciate the opportunity to provide this report for our work completed on 04 May 2020 at the above address.

PURPOSE

The purpose of this project was to search for underground utilities within the project boundaries provided by the client.

EQUIPMENT

- **400 MHz GPR Antenna.** The antenna is mounted in a stroller frame which rolls over the surface. The surface needs to be reasonably smooth and unobstructed in order to obtain readable scans. Obstructions such as curbs, landscaping, and vegetation will limit the feasibility of GPR. The data is displayed on a screen and marked in the field in real time. GPR works by sending pulses of energy into a material and recording the strength and the time required for the return of the reflected signal. Reflections are produced when the energy pulses enter into a material with different electrical properties from the material it left. The strength of the reflection is determined by the contrast in signal speed between the two materials. The total depth achieved can be as much as 8' or more with this antenna but can vary widely depending on the conductivity of the materials. Depths provided should always be treated as estimates as their accuracy can be affected by multiple factors. For more information, please visit: [Link](#)
- **Electromagnetic Pipe Locator.** The EM locator can detect the electromagnetic fields from live power or radio frequency signals. It can also be used in conjunction with a transmitter to connect directly to accessible, metallic pipes, risers, or tracer wires. A current is sent through the pipe or tracer wire at a specific frequency and the resulting EM field can then be detected by the receiver. The receiver is moved over the surface without coming in contact with the ground so it is not affected by terrain. Depths provided should always be treated as estimates as their accuracy can be affected by multiple factors. Depths achieved can be as much as 20' depending on the type of signal being traced or methods used. For more information, please visit: [Link](#)
- **GPS.** This handheld GPS unit offers accuracy down to 4 inches, however, the accuracy will depend on the satellite environment and obstructions and should not be considered to be survey-grade. Features can be collected as points, lines, or areas and then exported into Google Earth or overlaid on a CAD drawing. For more information, please visit: [Link](#)

PROCESS

Initial GPR scans were collected in order to evaluate the data and calibrate the equipment. Based on these findings, a scanning strategy is formed, typically consisting of scanning the entire area in a grid with 5'-10' scan spacing in order to locate any potential utilities that were not found with the pipe locator. The GPR data is interpreted in real time and anomalies in the data are located and marked on the surface along with their depths using spray paint, pin flags, etc. Depths are dependent on the dielectric of the materials being scanned so depth accuracy can vary throughout a site. Relevant scan examples were saved and will be provided in this report.

LIMITATIONS

Please keep in mind that there are limitations to any subsurface investigation. The equipment may not achieve maximum effectiveness due to soil conditions, above ground obstructions, reinforced concrete, and a variety of other factors. No subsurface investigation or equipment can provide a complete image of what lies below. Our results should always be used in conjunction with as many methods as possible including consulting existing plans and drawings, exploratory excavation or potholing, visual inspection of above ground features, and utilization of services such as One Call/811.

At this site, our scans were limited by curbs, uneven terrain, vegetation, trees, buildings, athletic equipment, columns, fences, and poor signal penetration.

FINDINGS

We found that the soil allowed for maximum GPR depth penetration of approximately 3' in most areas. We were able to locate multiple electric lines, which were marked with red paint, water line, which were marked with blue paint, communication lines were marked with orange paint, storm lines were marked with green paint and unknown anomalies, which was marked with pink paint. All depths were assigned where applicable.

The following page will provide a Google Map Overlay of our findings.



| | | | |
|-------------------------------|--|---|---|
| <p>Site Map with Findings</p> | | <p>2000 Pennington Rd Ewing, NJ</p> |  |
|-------------------------------|--|---|---|

CLOSING

GPRS, Inc. has been in business since 2001, specializing in underground storage tank location, concrete scanning, utility locating, and shallow void detection for projects throughout the United States. I encourage you to visit our website (www.gprsinc.com) and contact any of the numerous references listed.

GPRS appreciates the opportunity to offer our services, and we look forward to continuing to work with you on future projects. Please feel free to contact us for additional information or with any questions you may have regarding this report.

Signed,



Stephen Logue
Project Manager – Philadelphia, PA



267.547.0817

steve.logue@gprsinc.com

www.gprsinc.com

Attachment C

TCNJ COVID-19 CONTRACTOR WORK AREA REQUIREMENTS



TCNJ THE COLLEGE OF NEW JERSEY

The following information is being gathered to address all TCNJ COVID-19 CONTRACTOR WORKER AREAS

Definitions:

- **COVID-19:** A respiratory disease, caused by the SARS-CoV-2 virus; symptoms include mild to severe respiratory illness with fever, cough, difficulty breathing, and sore throat
- **Worker:** Any person who is conducting work on TCNJ's campus. This includes contractors, consultants, vendors, sub-contractors, and TCNJ employees entering areas where contractors, consultants and/or vendors are working.

Workers who CANNOT come to campus:

Workers who are known to be infected with COVID-19, have symptoms of the disease, or have been exposed to someone known to be infected (whether they show symptoms or not):

- Do NOT report to work, they should call their doctor for guidance;
- Promptly notify their company/supervisor that they cannot come to TCNJ;
- Promptly notify TCNJ if the worker was on campus 2 days before symptoms started;
- Promptly notify TCNJ and on-site workers of any suspected or known exposure to persons with COVID-19 symptoms, subject to confidentiality requirements in the Americans with Disabilities Act (ADA);
- TCNJ will work with their Certified Industrial Hygienist (CIH) to ensure the appropriate cleaning and disinfecting procedures for the worksite when a worker has been diagnosed with COVID-19;

Guidance for workers without symptoms working on campus:

- If symptoms start during the work shift, the worker shall immediately separate, notify their supervisor and TCNJ, leave campus, and contact their doctor for guidance;
- Require workers and visitors to wear cloth face coverings, and require workers to wear gloves. The employer must provide these face coverings and gloves for employees. If a visitor refuses for a non-medical reason, they must be denied entry;
- Require everyone to maintain 6 feet of physical or "social" distancing whenever possible;
- At all times, avoid touching another person's phone, desk, personal items, office, or other work tools and equipment, whenever possible. If necessary, clean and disinfect them before and after use;
- Drop off tools, keys, packages, or other equipment for others to pick up. Avoid direct deliver/contact with others. If necessary, clean and disinfect them before and after use;
- Prohibit non-essential visitors from entering the worksite;
- Limit all worksite meetings and groups to fewer than 10 people in an area that promotes enough room for physical/social distancing;
- Stagger start and stop times to limit the number of people entering and leaving at the same time;

- Stagger lunch breaks and work times to minimize the number of people on campus while safely continuing operations;
- Restrict the number of individuals who can access common areas such as restrooms and breakrooms at the same time;
- Workers are required to complete infection control practices such as regular hand washing, coughing and sneezing etiquette, and proper tissue usage;
- Limit sharing of tools, equipment, and machinery or disinfect tools when there is a need to share them;
- Hand sanitizer and wipes for workers and visitors are to be available;
- SMOKING – NO SMOKING on TCNJ construction sites is strictly enforced. After smoking at an appropriate location (at least 10 feet of a building door) the worker is to wash their hands and replace their gloves before returning to work;
- Continue to follow all guidelines and directives issued by the New Jersey Department of Health (NJDOH), the Center for Disease Control and Prevention (CDC), and the Occupational Safety and Health Administration (OSHA) for maintaining a clean, safe and healthy work environment;
- Continue to follow the State of NJ Executive Orders and Social Distancing Guidance for Essential Businesses, specifically for essential construction (<https://covid19.nj.gov/faqs/nj-information/general-public/if-im-a-customer-employee-or-operator-of-a-business-what-social-distancing-guidelines-should-i-follow>).

In addition the College requires the following to be supplied to the TCNJ point of contact from all contractors, consultant, vendors:

- List of all people (including visitors) on campus each day to the person who holds your contract (TCNJ's project manager or campus contact);
- List of rooms and spaces each worker or visitor occupied and/or travelled through each day.

E:\SCE\Ewing\9899.021 Ewing\9899.021 Field Hockey and Lacrosse\Contract Amendment - E-layer\Sheets\9899.021 01 Cover Sheet.dwg Thu, Jul 30, 2020 - 2:49pm kdama SUBURBAN CONSULTING ENGINEERS, INC.

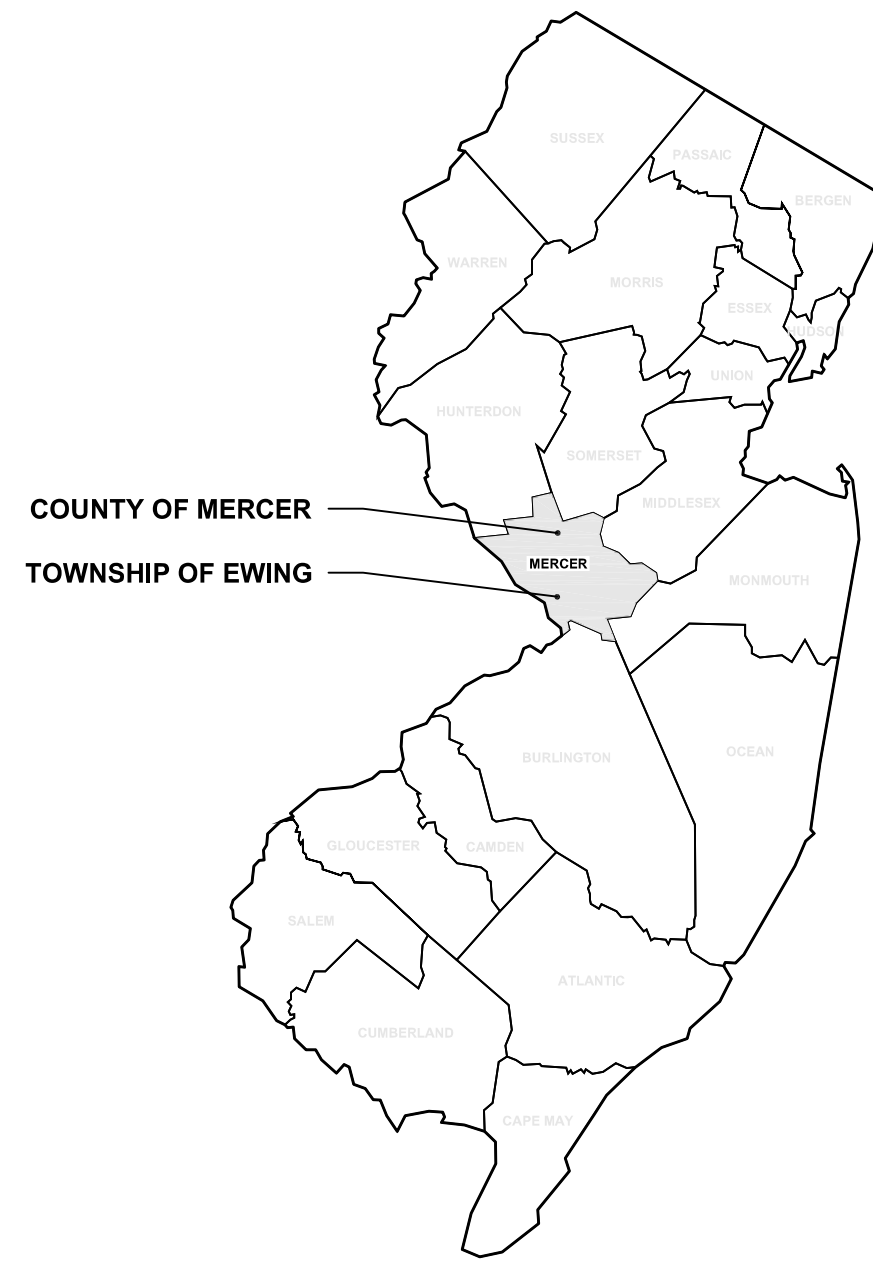

STATE OF NEW JERSEY

THE COLLEGE OF NEW JERSEY FIELD HOCKEY/LACROSSE FIELD E-LAYER REPLACEMENT TOWNSHIP OF EWING, COUNTY OF MERCER, STATE OF NEW JERSEY

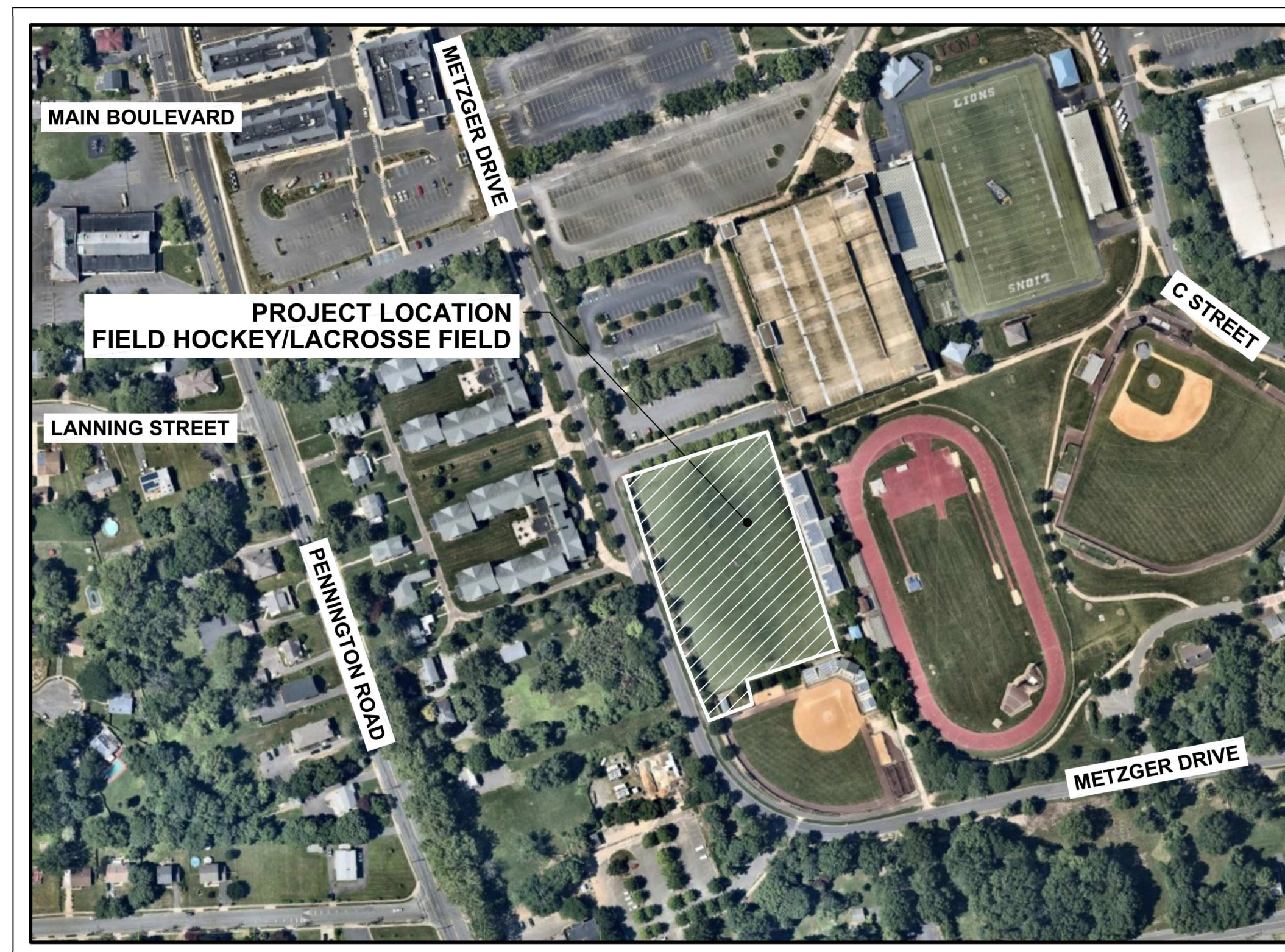

SOURCE: NEARMAP IMAGERY 2018.

| UTILITIES | |
|---|--|
| PSE&G - ELECTRIC | |
| COMCAST - TELEPHONE / INTERNET | |
| PSE&G - GAS | |
| TRENTON WATER WORKS - WATER | |
| COMCAST - CABLE / INTERNET | |
| EWING LAWRENCE SEWERAGE AUTHORITY - SEWER | |

NOTE:
ON-SITE UTILITIES ARE MOSTLY THE RESPONSIBILITY OF CAMPUS UTILITY SERVICES AT TCNJ. PRIOR TO ANY EXCAVATION, CONTRACTOR MUST HAVE ALL UTILITIES MARKED OUT BY THE APPROPRIATE UTILITY COMPANIES --> 1-800-272-1000 OR 811.



KEY MAP



SCALE: 1" = 200'



INDEX OF DRAWINGS

| SHEET | TITLE | REVISION |
|-------|--|----------|
| 1 | COVER SHEET | - |
| 2 | LEGEND AND GENERAL NOTES | - |
| 3 | EXISTING CONDITIONS AND DEMOLITION PLAN | - |
| 4 | SITE LAYOUT, GRADING, DRAINAGE, AND SOIL EROSION AND SEDIMENT CONTROL PLAN | - |
| 5 | CONSTRUCTION DETAILS AND SOIL EROSION NOTES AND DETAILS | - |

| REVISIONS | | | | |
|-------------------------------------|-----|------------|-----|-----|
| ISSUED FOR CONSTRUCTION DESCRIPTION | NO. | DATE | BY | CHK |
| | - | 07/31/2020 | KRD | RCG |

THE COLLEGE OF NEW JERSEY FIELD HOCKEY/LACROSSE FIELD E-LAYER REPLACEMENT TOWNSHIP OF EWING, COUNTY OF MERCER, STATE OF NEW JERSEY

COVER SHEET

DAREN J. PHIL, PE
NJ PROFESSIONAL ENGINEER
LICENSE NO. 240E03619100

DATE: 07/31/2020

SC SUBURBAN CONSULTING ENGINEERS, INC.
COA NO: 24C-A32007500
21NLE0004200
- Civil Engineers - Municipal Engineers -
- Landscape Architects -
- Planners - Environmentalists - Land Surveyors -
96 US Highway 206, Suite 101 2430 Highway 34, Bldg. A Suite 1R
Flanders, N.J. 07836 - 973.398.1776 Wall, N.J. 08736 - 732.282.1776
EXCELLENCE ♦ ECONOMY ♦ ENVIRONMENT

E:\SCE\Ewing\8999.021 Field Hockey and Lacrosse\Contract Amendment - E-Layer\Sheets\8999.021 03 Existing Conditions and Demolition Plan.dwg Tue, Aug 04, 2020 - 12:01 pm kdama SUBURBAN CONSULTING ENGINEERS, INC.

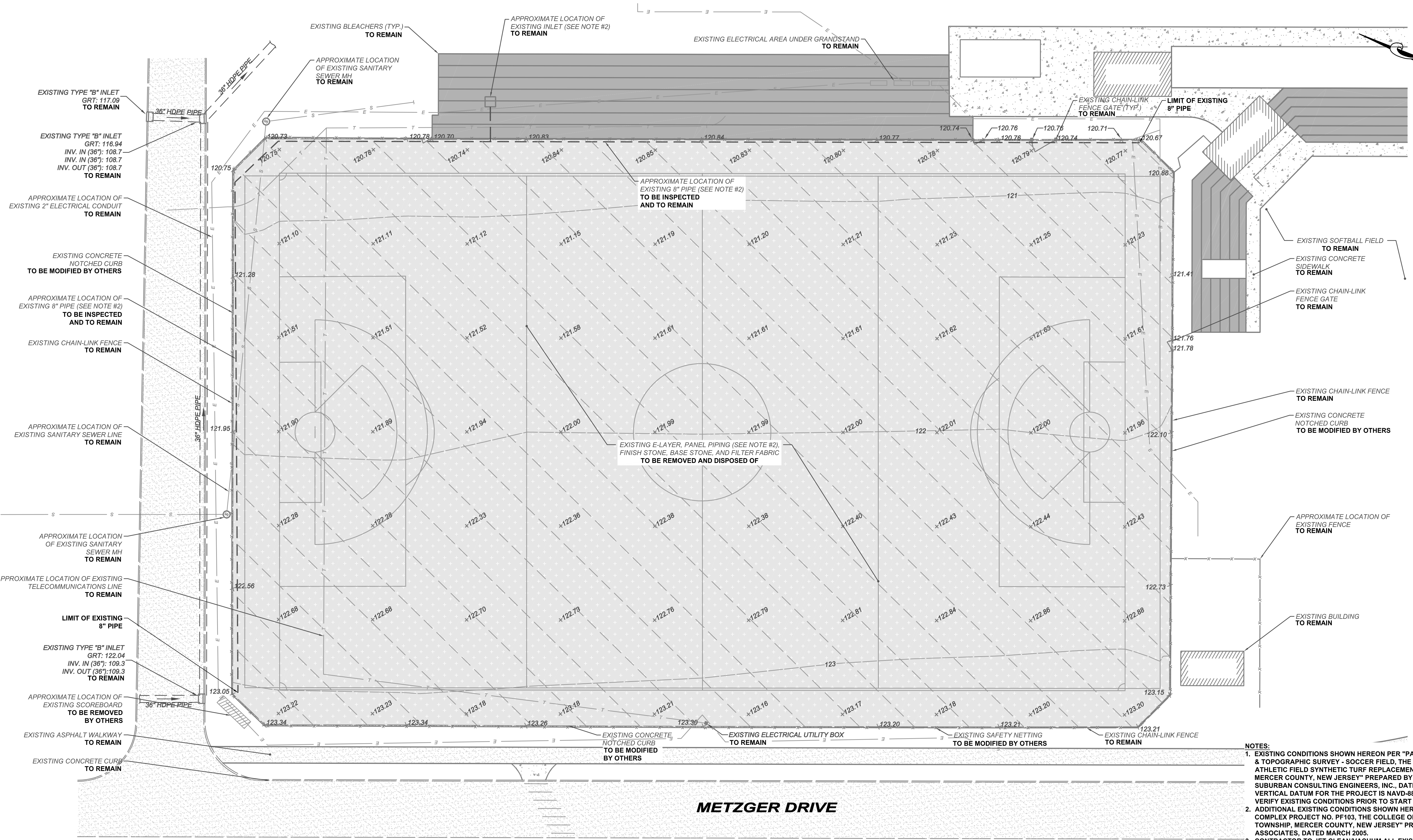

N.J.S.P.C.S.
(NAD-83)

- NOTES:**
- EXISTING CONDITIONS SHOWN HEREON PER "PARTIAL EXISTING CONDITIONS & TOPOGRAPHIC SURVEY - SOCCER FIELD, THE COLLEGE OF NEW JERSEY ATHLETIC FIELD SYNTHETIC TURF REPLACEMENT, TOWNSHIP OF EWING, MERCER COUNTY, NEW JERSEY" PREPARED BY JOSEPH D. PHIL, PLS OF SUBURBAN CONSULTING ENGINEERS, INC., DATED AUGUST 29, 2018. VERTICAL DATUM FOR THE PROJECT IS NAVD-88. THE CONTRACTOR SHALL VERIFY EXISTING CONDITIONS PRIOR TO START OF CONSTRUCTION.
 - ADDITIONAL EXISTING CONDITIONS SHOWN HEREON PER "ATHLETIC FIELD COMPLEX PROJECT NO. PF103, THE COLLEGE OF NEW JERSEY, EWING TOWNSHIP, MERCER COUNTY, NEW JERSEY" PREPARED BY KINSEY ASSOCIATES, DATED MARCH 2005.
 - CONTRACTOR TO JET CLEAN/VACUUM ALL EXISTING STORM DRAINAGE PIPING TO REMAIN IN VICINITY OF PROJECT SITE TO DOWNSTREAM INLETS AFTER CONSTRUCTION. NO SEPARATE PAYMENT WILL BE MADE.
 - CONTRACTOR TO PROTECT ALL INLETS DURING CONSTRUCTION IN ACCORDANCE WITH APPLICABLE SOIL EROSION AND SEDIMENT CONTROL STANDARDS.
 - CONTRACTOR TO REMOVE APPROXIMATELY 7 INCHES, IN TOTAL, OF FINISH AND BASE STONE.

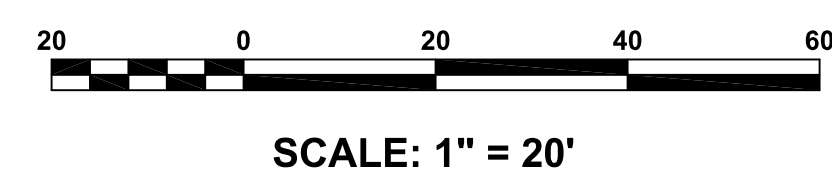

NOTICE
THIS DRAWING AND ALL INFORMATION CONTAINED HEREIN IS AUTHORIZED FOR USE ONLY BY THE PARTY FOR WHOM THE WORK WAS CONTRACTED OR TO WHOM IT IS CERTIFIED.
THIS DRAWING MAY NOT BE COPIED, REUSED, DISCLOSED, DISTRIBUTED, OR RELIED UPON FOR ANY OTHER PURPOSE WITHOUT THE WRITTEN CONSENT OF
SUBURBAN CONSULTING ENGINEERS, INC.
PER N.J.A.C. ELECTRONIC SUBMISSIONS NOT CONTAINING A VALID DIGITAL SEAL OR PAPER COPIES NOT CONTAINING A PASSES SEAL ARE NOT ORIGINALS AND MAY HAVE BEEN ALTERED.
© COPYRIGHT 2020 SUBURBAN CONSULTING ENGINEERS, INC.™
ALL RIGHTS RESERVED

| ISSUED FOR CONSTRUCTION | | | | |
|-------------------------|-----|------------|-----|------|
| DESCRIPTION | NO. | DATE: | BY: | CHK: |
| | | 07/31/2020 | KRD | RCG |
| REVISIONS | | | | |

DRAWN BY:
KRD
07/31/2020
CHECKED BY:
RCG
07/31/2020
CHECKED BY:

DAREN J. PHIL, PE
NJ PROFESSIONAL ENGINEER
LICENSE NO. 34GE03619100
(Signature)
DATE: 07/31/2020

SC E SUBURBAN CONSULTING ENGINEERS, INC.
Civil Engineers - Municipal Engineers -
Landscape Architects -
Planners - Environmentalists - Land Surveyors -
96 US Highway 206, Suite 101 2430 Highway 34, Bldg. A Suite 1B
Flanders, NJ 07836 - 973.398.1776 Wall, NJ 08736 - 732.282.1776
EXCELLENCE ♦ ECONOMY ♦ ENVIRONMENT

**THE COLLEGE OF NEW JERSEY
FIELD HOCKEY/LACROSSE FIELD
E-LAYER REPLACEMENT**
TOWNSHIP OF EWING, COUNTY OF MERCER, STATE OF NEW JERSEY
EXISTING CONDITIONS AND DEMOLITION PLAN

PROJECT NUMBER:
SCE-9899.021
SCALE:
1"=20'
SHEET 3 OF 5
REVISION _

E:\SCE\Ewing\9899.021 Field Hockey and Lacrosse\Contract Amendment - E-Layer\Sheets\9899.021 04 Site Grading and Drainage Plan.dwg Tue, Aug 04, 2020 - 12:17pm kdama SUBURBAN CONSULTING ENGINEERS, INC.

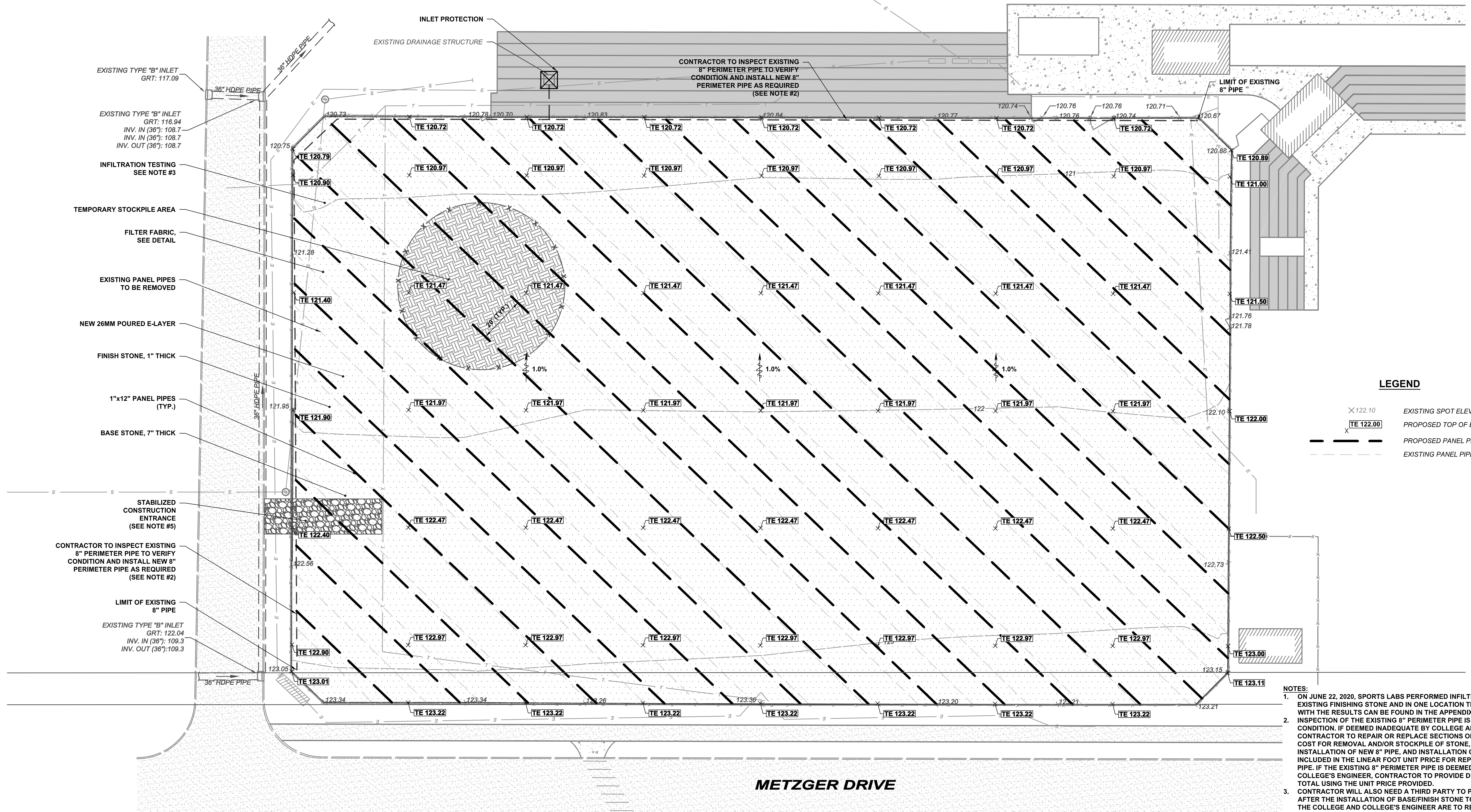

LEGEND

- X 122.10 EXISTING SPOT ELEVATION
- TE 122.00 PROPOSED TOP OF E-LAYER ELEVATION
- - - - - PROPOSED PANEL PIPE
- - - - - EXISTING PANEL PIPE

- NOTES:**
- ON JUNE 22, 2020, SPORTS LABS PERFORMED INFILTRATION TESTING ON THE EXISTING FINISHING STONE AND IN ONE LOCATION THE BASE STONE. THE REPORT WITH THE RESULTS CAN BE FOUND IN THE APPENDIX OF THE SPECIFICATIONS.
 - INSPECTION OF THE EXISTING 8" PERIMETER PIPE IS REQUIRED TO DETERMINE ITS CONDITION. IF DEEMED INADEQUATE BY COLLEGE AND COLLEGE'S ENGINEER, CONTRACTOR TO REPAIR OR REPLACE SECTIONS OF THE PIPE AS NECESSARY. COST FOR REMOVAL AND/OR STOCKPILE OF STONE, REMOVAL OF EXISTING PIPE, INSTALLATION OF NEW 8" PIPE, AND INSTALLATION OF TRENCH STONE TO BE INCLUDED IN THE LINEAR FOOT UNIT PRICE FOR REPLACE EXISTING 8" PERIMETER PIPE. IF THE EXISTING 8" PERIMETER PIPE IS DEEMED ADEQUATE BY COLLEGE AND COLLEGE'S ENGINEER, CONTRACTOR TO PROVIDE DEDUCT AMOUNT FROM BID TOTAL USING THE UNIT PRICE PROVIDED.
 - CONTRACTOR WILL ALSO NEED A THIRD PARTY TO PERFORM INFILTRATION TESTS AFTER THE INSTALLATION OF BASE/FINISH STONE TO DETERMINE THE POROSITY. THE COLLEGE AND COLLEGE'S ENGINEER ARE TO REVIEW THE INFILTRATION REPORT FOR APPROVAL PRIOR TO THE INSTALLATION OF THE E-LAYER. AFTER THE INSTALLATION OF THE E-LAYER, THE CONTRACTOR IS TO HAVE A THIRD PARTY PERFORM INFILTRATION TESTS TO DETERMINE THE POROSITY. THE REPORT IS TO BE REVIEWED BY THE COLLEGE AND COLLEGE'S ENGINEER FOR APPROVAL.
 - CONTRACTOR TO JET CLEAN/VACUUM ALL EXISTING STORM DRAINAGE PIPING TO REMAIN IN VICINITY OF PROJECT SITE TO DOWNSTREAM INLETS AFTER CONSTRUCTION. NO SEPARATE PAYMENT WILL BE MADE.
 - CONTRACTOR TO RESTORE AREAS DAMAGED DURING CONSTRUCTION TO ITS ORIGINAL CONDITION. THIS INCLUDES ANY LANDSCAPING, FENCING, CURBING, PAVEMENT, AND ALL ELSE REQUIRED FOR SITE RESTORATION.

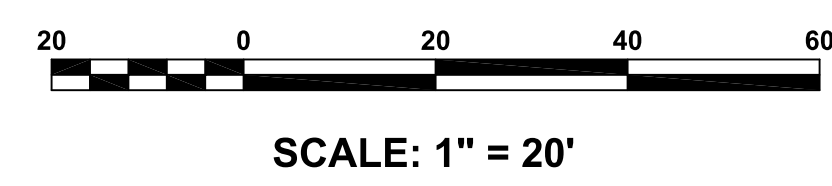

NOTICE
THIS DRAWING AND ALL INFORMATION CONTAINED HEREIN IS AUTHORIZED FOR USE ONLY BY THE PARTY FOR WHOM THE WORK WAS CONTRACTED OR TO WHOM IT IS CERTIFIED.
THIS DRAWING MAY NOT BE COPIED, REUSED, DISCLOSED, DISTRIBUTED, OR RELIED UPON FOR ANY OTHER PURPOSE WITHOUT THE WRITTEN CONSENT OF SUBURBAN CONSULTING ENGINEERS, INC.
PER N.J.A.C. ELECTRONIC SUBMISSIONS NOT CONTAINING A VALID DIGITAL SEAL OR PAPER COPIES NOT CONTAINING A PAPER SEAL ARE NOT ORIGINALS AND MAY HAVE BEEN ALTERED.
© COPYRIGHT 2020 SUBURBAN CONSULTING ENGINEERS, INC.™
ALL RIGHTS RESERVED

| ISSUED FOR CONSTRUCTION | | | | |
|-------------------------|-----|------------|-----|------|
| DESCRIPTION | NO. | DATE: | BY: | CHK: |
| | | 07/31/2020 | KRD | RCG |
| REVISIONS | | | | |

DRAWN BY:
KRD
07/31/2020
CHECKED BY:
RCG
07/31/2020
CHECKED BY:

DAREN J. PHIL, PE
NJ PROFESSIONAL ENGINEER
LICENSE NO. 34603619100
(Signature)
DATE: 07/31/2020

SC E SUBURBAN CONSULTING ENGINEERS, INC.
Civil Engineers - Municipal Engineers - Planners - Environmentalists - Land Surveyors -
96 US Highway 206, Suite 101 Wall, N.J. 08736 - 973.398.1776
2430 Highway 34, Bldg. A Suite 1B Wall, N.J. 08736 - 732.282.1776
EXCELLENCE ♦ ECONOMY ♦ ENVIRONMENT

THE COLLEGE OF NEW JERSEY
FIELD HOCKEY/LACROSSE FIELD
E-LAYER REPLACEMENT
TOWNSHIP OF EWING, COUNTY OF MERCER, STATE OF NEW JERSEY
SITE LAYOUT, GRADING, DRAINAGE, AND SOIL EROSION AND SEDIMENT CONTROL PLAN

PROJECT NUMBER:
SCE-9899.021
SCALE:
1"=20'
SHEET 4 OF 5
REVISION: _

MERCER COUNTY SOIL CONSERVATION DISTRICT SOIL EROSION & SEDIMENT CONTROL NOTES

- THE MERCER COUNTY SOIL CONSERVATION DISTRICT SHALL BE NOTIFIED 48 HOURS PRIOR TO STARTING LAND DISTURBANCE ACTIVITY. NOTICE MAY BE MAILED, FAXED OR EMAILED TO:
 MCSCD, 590 HUGHES DRIVE, HAMILTON SQUARE, NJ 08690
 PHONE: 609-586-9603 FAX: 609-586-1117 EMAIL: PAULS1MERCER@AOL.COM
- IF APPLICABLE TO THIS PROJECT, THE OWNER SHOULD BE AWARE OF HIS OR HER OBLIGATION TO FILE FOR A NJDES CONSTRUCTION ACTIVITY STOP/WATER 503 PERMIT (NJ0008823) VIA THE NJDES ONLINE PERMITTING SYSTEM (WWW.NJ.GOV/DEP/ONLINE) AND TO MAINTAIN THE ASSOCIATED BEST MANAGEMENT PRACTICES AND STORMWATER POLLUTION PREVENTION PLAN SELF-INSPECTION LOGBOOK ONSITE AT ALL TIMES. THIS PERMIT MUST BE FILED PRIOR TO THE START OF SOIL DISTURBANCE. THE ONLINE APPLICATION PROCESS WILL REQUIRE ENTRY OF AN SCD CERTIFICATION CODE, WHICH IS PROVIDED BY THE SOIL CONSERVATION DISTRICT UPON CERTIFICATION OF THE SOIL EROSION AND SEDIMENT CONTROL PLAN.
- THE MERCER COUNTY SOIL CONSERVATION DISTRICT SHALL BE NOTIFIED OF ANY CHANGES IN OWNERSHIP.
- ANY CHANGES TO THE CERTIFIED SOIL EROSION AND SEDIMENT CONTROL PLAN, INCLUDING AN INCREASE IN THE LIMIT OF DISTURBANCE, WILL REQUIRE THE SUBMISSION OF REVISED SOIL EROSION AND SEDIMENT CONTROL PLANS TO THE DISTRICT FOR RECERTIFICATION. THE REVISED PLANS MUST MEET ALL CURRENT STATE SOIL EROSION & SEDIMENT CONTROL STANDARDS.
- A COPY OF THE CERTIFIED SOIL EROSION AND SEDIMENT CONTROL PLAN SHALL BE MAINTAINED ON SITE AT ALL TIMES.
- ALL SOIL EROSION AND SEDIMENT CONTROL PRACTICES SHALL BE INSTALLED PRIOR TO ANY MAJOR SOIL DISTURBANCES, OR IN THEIR PROPER SEQUENCE AS OUTLINED WITHIN THE SEQUENCE OF CONSTRUCTION ON THE CERTIFIED SOIL EROSION AND SEDIMENT CONTROL PLAN, AND MAINTAINED UNTIL PERMANENT PROTECTION IS ESTABLISHED.
- ALL WORK SHALL BE DONE IN ACCORDANCE WITH THE CURRENT STANDARDS FOR SOIL EROSION AND SEDIMENT CONTROL IN NJ. IF LANGUAGE CONTAINED WITHIN ANY OTHER PERMIT FOR THIS PROJECT IS MORE RESTRICTIVE THAN (BUT NOT CONTRADICTORY TO) WHAT IS CONTAINED WITHIN THESE NOTES OR ON THE CERTIFIED SOIL EROSION AND SEDIMENT CONTROL PLAN, THEN THE MORE RESTRICTIVE PERMIT REQUIREMENTS SHALL BE FOLLOWED.
- THE STANDARD FOR STABILIZED CONSTRUCTION ACCESS REQUIRES THE INSTALLATION OF A 1 1/2" TO 2 1/2" CLEAN STONE TRACKING PAD AT ALL CONSTRUCTION DRIVEWAYS IMMEDIATELY AFTER INITIAL SITE DISTURBANCE, WHETHER IDENTIFIED ON THE CERTIFIED PLAN OR NOT. THE WIDTH SHALL SPAN THE FULL WIDTH OF EGRESS, AND LENGTH SHALL BE 50 FT. OR MORE, DEPENDING ON SITE CONDITIONS AND AS REQUIRED BY THE STANDARD. THIS SHALL INCLUDE INDIVIDUAL LOT ACCESS POINTS WITHIN RESIDENTIAL SUBDIVISIONS. IF THE EGRESS IS TO A COUNTY ROAD, THEN A 20 FT. LONG PAVED TRANSITION SHALL BE PROVIDED BETWEEN THE EDGE OF PAVEMENT AND THE STONE ACCESS PAD.
- A SUB-BASE COURSE WILL BE APPLIED IMMEDIATELY FOLLOWING ROUGH GRADING AND INSTALLATION OF IMPROVEMENTS IN ORDER TO STABILIZE STREETS, ROADS, DRIVEWAYS AND PARKING AREAS. IN AREAS WHERE NO UTILITIES ARE PRESENT, THE SUB-BASE SHALL BE INSTALLED WITHIN 15 DAYS OF PRELIMINARY GRADING, PROVIDED THAT ALL OTHER REQUIREMENTS RELATED TO DETENTION BASINS, SWALES AND THE SEQUENCE OF CONSTRUCTION HAVE BEEN MET.
- ANY DISTURBED AREAS THAT WILL BE LEFT EXPOSED MORE THAN 14 DAYS AND NOT SUBJECT TO CONSTRUCTION ACTIVITY WILL IMMEDIATELY RECEIVE TEMPORARY STABILIZATION. IF THE SEASON PREVENTS ESTABLISHMENT OF A TEMPORARY VEGETATIVE COVER, OR IF THE AREA IS NOT TOPSOILED, THEN THE DISTURBED AREAS WILL BE MULCHED WITH STRAW, OR EQUIVALENT MATERIAL, AT A RATE OF TWO (2) TONS PER ACRE, ACCORDING TO STATE STANDARDS. SLOPED AREAS IN EXCESS OF 3H:1V SHALL BE PROVIDED WITH EROSION CONTROL BLANKETS. CRITICAL AREAS SUBJECT TO EROSION ON STEEP SLOPES, ROADWAY EMBANKMENTS, ENVIRONMENTALLY SENSITIVE AREAS WILL RECEIVE TEMPORARY STABILIZATION IMMEDIATELY AFTER INITIAL DISTURBANCE OR ROUGH GRADING.
- ANY STEEP SLOPES (I.E. SLOPES GREATER THAN 3:1) RECEIVING PIPELINE OR UTILITY INSTALLATION WILL BE BACKFILLED AND STABILIZED DAILY, AS THE INSTALLATION PROCEEDS.
- PERMANENT VEGETATION SHALL BE SEED OR SODDED ON ALL EXPOSED AREAS WITHIN TEN (10) DAYS AFTER FINAL GRADING AND TOPSOILING. ALL AGRONOMIC REQUIREMENTS CONTAINED WITHIN THE STANDARDS AND ON THE CERTIFIED PLAN SHALL BE EMPLOYED. MULCH WITH BINDER, IN ACCORDANCE WITH THE STANDARDS, SHALL BE USED ON ALL SEEDED AREAS. SAVE ALL TAGS AND/OR BAGS USED FOR SEED, LIME AND FERTILIZER, AND PROVIDE THEM TO THE DISTRICT INSPECTOR TO VERIFY THAT MIXTURES AND RATES MEET THE STANDARDS. AT THE TIME WHEN THE SITE PREPARATION FOR PERMANENT VEGETATIVE STABILIZATION IS GOING TO BE ACCOMPLISHED, ANY SOIL THAT WILL NOT PROVIDE A SUITABLE ENVIRONMENT TO SUPPORT ADEQUATE VEGETATIVE GROUND COVER, SHALL BE REMOVED OR TREATED IN SUCH A WAY THAT WILL PERMANENTLY ADJUST THE SOIL CONDITIONS AND RENDER IT SUITABLE FOR VEGETATIVE GROUND COVER. IF THE REMOVAL OR TREATMENT OF THE SOIL WILL NOT PROVIDE SUITABLE CONDITIONS, THEN NON-VEGETATIVE MEANS OF PERMANENT GROUND STABILIZATION WILL HAVE TO BE EMPLOYED.
- DURING THE COURSE OF CONSTRUCTION, SOIL COMPACTION MAY OCCUR WITHIN HAUL ROUTES, STAGING AREAS AND OTHER PROJECT AREAS. IN ACCORDANCE WITH THE STANDARD FOR TOPSOILING, COMPACTED SURFACES SHOULD BE SCARIFIED 6" TO 12" IMMEDIATELY PRIOR TO TOPSOIL APPLICATION. THIS WILL HELP ENSURE A GOOD BOND BETWEEN THE TOPSOIL AND SUBSOIL. THIS PRACTICE IS PERMISSIBLE ONLY WHERE THERE IS NO DANGER TO UNDERGROUND UTILITIES (CABLES, IRRIGATION SYSTEMS, ETC.).
- PRIOR TO SEEDING, TOPSOIL SHALL BE WORKED TO PREPARE A PROPER SEEDBED. THIS SHALL INCLUDE RAKING OF THE TOPSOIL AND REMOVAL OF DEBRIS AND STONES, ALONG WITH OTHER REQUIREMENTS OF THE STANDARD FOR PERMANENT VEGETATIVE COVER FOR SOIL STABILIZATION.
- IN ACCORDANCE WITH THE STANDARD FOR MANAGEMENT OF HIGH ACID PRODUCING SOILS, ANY SOIL HAVING A PH OF 4 OR LESS OR CONTAINING IRON SULFIDES SHALL BE BURIED WITH LIMESTONE IN ACCORDANCE WITH THE STANDARD AND BE COVERED WITH A MINIMUM OF 12" OF SOIL HAVING A PH OF 5 OR MORE PRIOR TO TOPSOIL APPLICATION AND SEEDBED PREPARATION. IF THE AREA IS TO RECEIVE TREE OR SHRUB PLANTINGS, OR IS LOCATED ON A SLOPE, THEN THE AREA SHALL BE COVERED WITH A MINIMUM OF 24" OF SOIL HAVING A PH OF 5 OR MORE.
- MULCHING TO THE STANDARDS IS REQUIRED FOR OBTAINING A CONDITIONAL REPORT OF COMPLIANCE. CONDITIONAL ROC'S ARE ONLY ISSUED WHEN THE SEASON PROHIBITS SEEDING. PERMANENT STABILIZATION MUST THEN BE COMPLETED DURING THE OPTIMUM SEEDING SEASON IMMEDIATELY FOLLOWING THE CONDITIONAL ROC, OR THE COMPLETION OF WORK IN A GIVEN AREA.
- HYDROSEEDING IS A TWO-STEP PROCESS. THE FIRST STEP INCLUDES SEED, FERTILIZER, LIME, ETC., ALONG WITH MINIMAL AMOUNTS OF MULCH TO PROMOTE CONSISTENCY, GOOD SEED-TO-SOIL CONTACT, AND GIVE A VISUAL INDICATION OF COVERAGE. UPON COMPLETION OF THE SEEDING OPERATION, HYDROMULCH SHOULD BE APPLIED AT A MINIMUM RATE OF 1500 LBS. PER ACRE IN SECOND STEP. THE USE OF HYDRO-MULCH, AS OPPOSED TO STRAW, IS LIMITED TO OPTIMUM SEEDING DATES AS LISTED IN THE STANDARDS. THE USE OF HYDROMULCH ON SLOPED AREAS IS DISCOURAGED.
- THE CONTRACTOR IS RESPONSIBLE FOR KEEPING ALL ADJACENT ROADS CLEAN DURING LIFE OF THE CONSTRUCTION PROJECT. ALL SEDIMENT WASHED, DROPPED, TRACKED OR SPILLED ONTO PAVED SURFACES SHALL BE IMMEDIATELY REMOVED.
- THE DEVELOPER SHALL BE RESPONSIBLE FOR REMEDIATING ANY EROSION OR SEDIMENT PROBLEMS THAT ARISE AS A RESULT OF ONGOING CONSTRUCTION, AND FOR EMPLOYING ADDITIONAL EROSION AND SEDIMENT CONTROL MEASURES AT THE REQUEST OF THE MERCER COUNTY SOIL CONSERVATION DISTRICT.
- CONDUIT OUTLET PROTECTION MUST BE INSTALLED AT ALL REQUIRED OUTFALLS PRIOR TO THE DRAINAGE SYSTEM BECOMING OPERATIONAL.
- ALL DETENTION / RETENTION BASINS MUST BE FULLY CONSTRUCTED (INCLUDING OF ALL STRUCTURAL COMPONENTS AND LINERS) AND PERMANENTLY STABILIZED PRIOR TO PAVING OR PRIOR TO THE ADDITION OF ANY IMPERVIOUS SURFACES. PERMANENT STABILIZATION INCLUDES, BUT MAY NOT BE LIMITED TO: TOPSOIL, SEED, STRAW MULCH AND BINDERS OR EROSION CONTROL BLANKETS ON ALL SEEDING. ALL AGRONOMIC REQUIREMENTS AS SPECIFIED ON THE CERTIFIED SOIL EROSION AND SEDIMENT CONTROL PLAN, INSTALLATION OF THE OUTFLOW CONTROL STRUCTURES AND DISCHARGE STORM DRAINAGE PIPING, LOW FLOW CHANNELS, CONDUIT OUTLET PROTECTION, EMERGENCY SPILLWAYS, AND LAP RING PROTECTION.
- THE RIDING SURFACE OF ALL UTILITY TRENCHES WITHIN PAVED AREAS SHALL BE 3/4" CLEAN STONE OR BASE PAVEMENT UNTIL SUCH TIME AS FINAL PAVEMENT HAS BEEN INSTALLED. TEMPORARY SOIL RIDING SURFACES ARE PROHIBITED.
- ALL CONSTRUCTION DEWATERING (TRENCHES, EXCAVATIONS, ETC.) MUST BE DONE THROUGH AN INLET OR OUTLET FILTER IN ACCORDANCE WITH THE STANDARD OR AS DEPICTED ON THE CERTIFIED SOIL EROSION AND SEDIMENT CONTROL PLAN. DISCHARGE LOCATIONS FOR THE DEWATERING OPERATION MUST CONTAIN PERENNIAL VEGETATION OR SIMILAR STABLE SURFACE.
- ALL SWALES OR CHANNELS THAT WILL RECEIVE RUNOFF FROM PAVED SURFACES MUST BE PERMANENTLY STABILIZED PRIOR TO THE INSTALLATION OF PAVEMENT. IF THE SEASON PROHIBITS THE ESTABLISHMENT OF PERMANENT STABILIZATION, THE SWALES OR CHANNELS MAY BE TEMPORARILY STABILIZED IN ACCORDANCE WITH THE STANDARDS.
- NJSA 4:24-39 ET SEQ. REQUIRES THAT NO CERTIFICATE OF OCCUPANCY OR TEMPORARY CERTIFICATE OF OCCUPANCY BE ISSUED BY THE MUNICIPALITY BEFORE THE PROVISIONS OF THE CERTIFIED SOIL EROSION AND SEDIMENT CONTROL PLAN HAVE BEEN SATISFIED. THEREFORE, ALL SITE WORK FOR SITE PLANS AND ALL WORK AROUND INDIVIDUAL LOTS IN SUBDIVISIONS MUST BE COMPLETED BEFORE THE DISTRICT ISSUES A REPORT OF COMPLIANCE OR CONDITIONAL REPORT OF COMPLIANCE, WHICH MUST BE FORWARDED TO THE MUNICIPALITY PRIOR TO THE ISSUANCE OF A CERTIFICATE OF OCCUPANCY OR TEMPORARY CERTIFICATE OF OCCUPANCY, RESPECTIVELY.

TABLE 16-1: DUST CONTROL MATERIALS

| MATERIAL | WATER DILUTION | TYPE OF NOZZLE | APPLY GALLONS / ACRE |
|--|----------------|----------------|---|
| ANIONIC ASPHALT EMULSION | 7 : 1 | COARSE SPRAY | 1,200 |
| LATEX EMULSION | 12.5 : 1 | FINE SPRAY | 235 |
| RESIN IN WATER | 4 : 1 | FINE SPRAY | 300 |
| POLYACRYLAMIDE (PAM) - SPRAY ON POLYACRYLAMIDE (PAM) - DRY SPRAY | | | APPLY ACCORDING TO MANUFACTURER'S INSTRUCTIONS. MAY ALSO BE USED AS AN ADDITIVE TO SEDIMENT BASINS TO FLOCCULATE AND PRECIPITATE SUSPENDED COLLOIDS. SEE SEDIMENT BASIN STANDARD (Pg. 26-1) |
| ACIDULATED SOY BEAN STICK | NONE | COARSE SPRAY | 1,200 |

TILLAGE - TO ROUGHEN SURFACE AND BRING CLODS TO THE SURFACE. THIS IS A TEMPORARY EMERGENCY MEASURE WHICH SHOULD BE USED BEFORE SOIL BLOWING STARTS. BEGIN PLOWING ON WINDWARD SIDE OF SITE. CHISEL-TYPE PLOWS SPACED ABOUT 12 INCHES APART, AND SPRING-TOOTHED HARROWS ARE EXAMPLES OF EQUIPMENT WHICH MAY PRODUCE THE DESIRED EFFECT.

SPRINKLING - SITE IS SPRINKLED UNTIL THE SURFACE IS WET.

BARRIERS - SOLID BOARD FENCES, SNOW FENCES, BURLAP FENCES, CRATE WALLS, BALES OF HAY, AND SIMILAR MATERIAL CAN BE USED TO CONTROL AIR CURRENTS AND SOIL BLOWING.

CALCIUM CHLORIDE - SHALL BE IN THE FORM OF LOOSE, DRY GRANULES OR FLAKES FINE ENOUGH TO FEED THROUGH COMMONLY USED SPREADERS AT A RATE THAT WILL KEEP SURFACE MOIST BUT NOT CAUSE POLLUTION OR PLANT DAMAGE. IF USED ON STEEPER SLOPES, THEN USE OTHER PRACTICES TO PREVENT WASHING INTO STREAMS OR ACCUMULATION AROUND PLANTS.

STONE - COVER SURFACE WITH CRUSHED STONE OR COARSE GRAVEL.

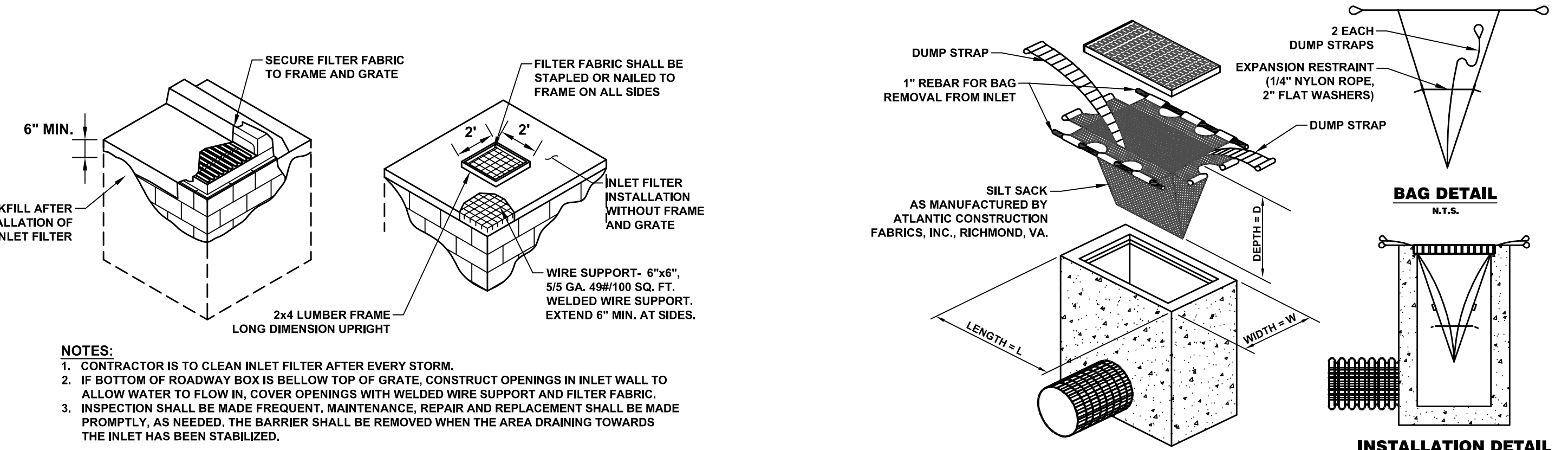

- NOTES:**
- CONTRACTOR IS TO CLEAN INLET FILTER AFTER EVERY STORM.
 - IF BOTTOM OF ROADWAY BOX IS BELOW TOP OF GRATE, CONSTRUCT OPENINGS IN INLET WALL TO ALLOW WATER TO FLOW IN, COVER OPENINGS WITH WELDED WIRE SUPPORT AND FILTER FABRIC.
 - INSPECTION SHALL BE MADE FREQUENT. MAINTENANCE, REPAIR AND REPLACEMENT SHALL BE MADE PROMPTLY, AS NEEDED. THE BARRIER SHALL BE REMOVED WHEN THE AREA DRAINING TOWARDS THE INLET HAS BEEN STABILIZED.

INLET FILTER DETAIL
N.T.S.

INLET PROTECTION DEVICE
N.T.S.

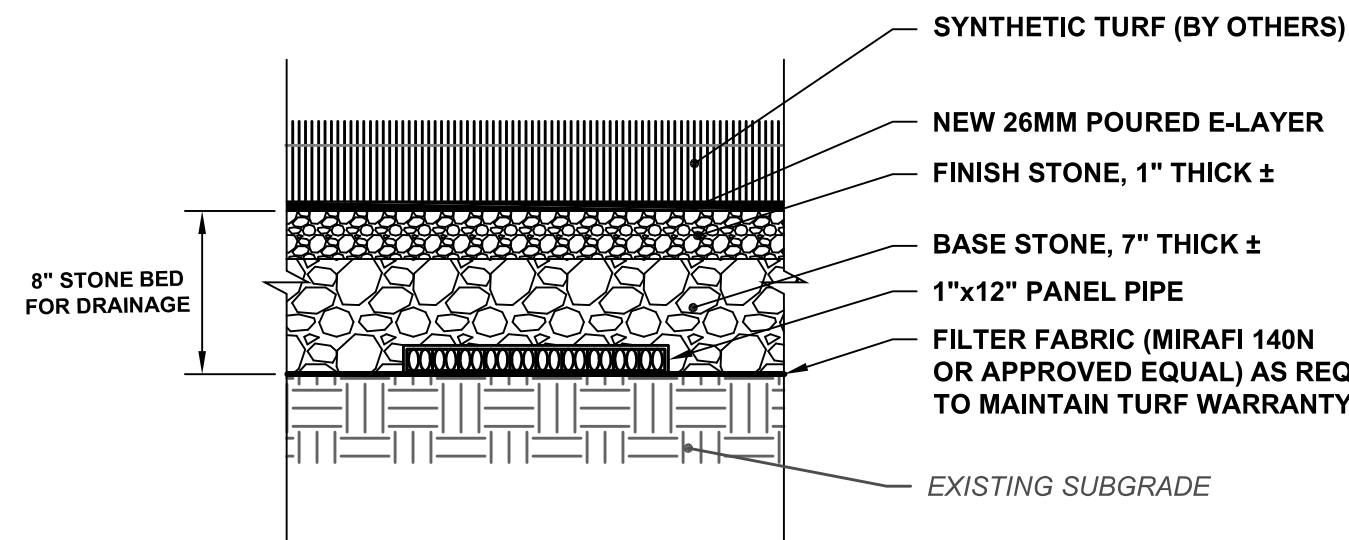

E-LAYER AND BASE DETAIL
N.T.S.

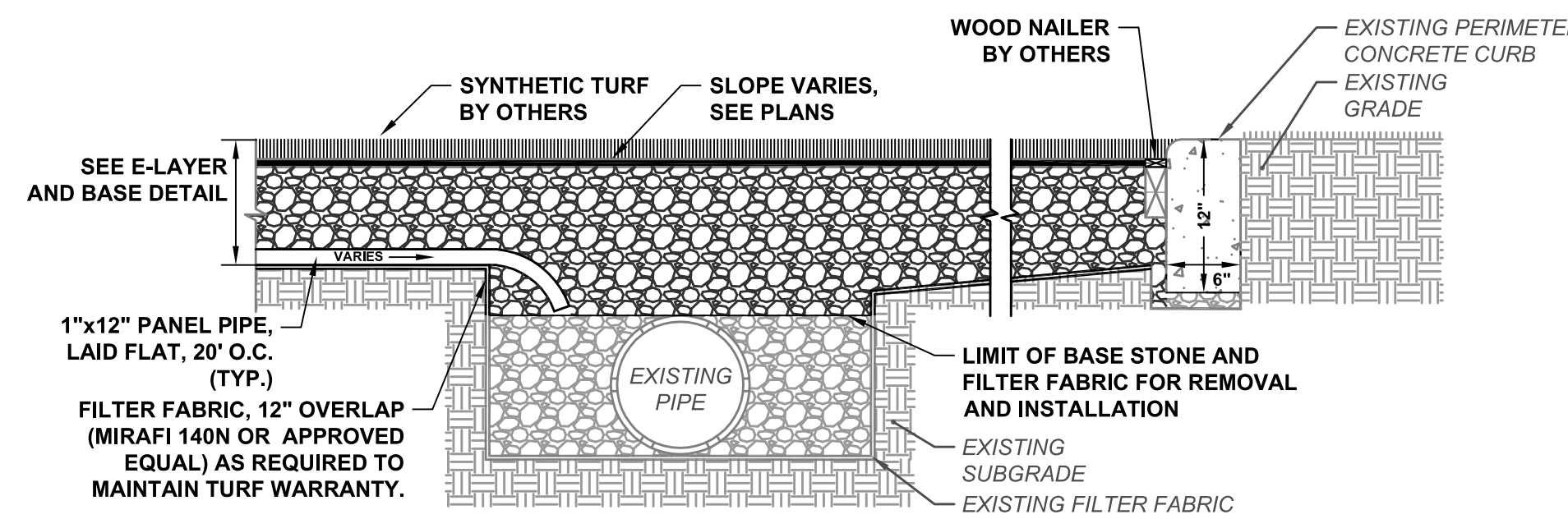

E-LAYER AND BASE TO CONCRETE CURB BY OTHERS
N.T.S.

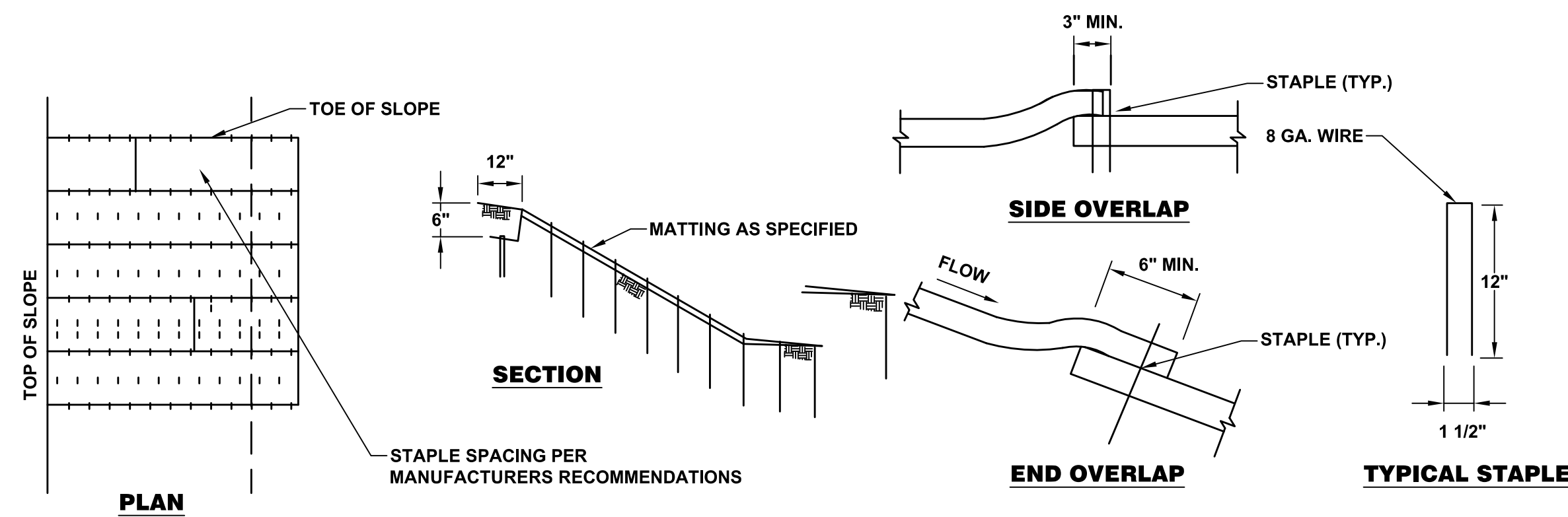

TOPSOIL STOCKPILE STABILIZATION
N.T.S.

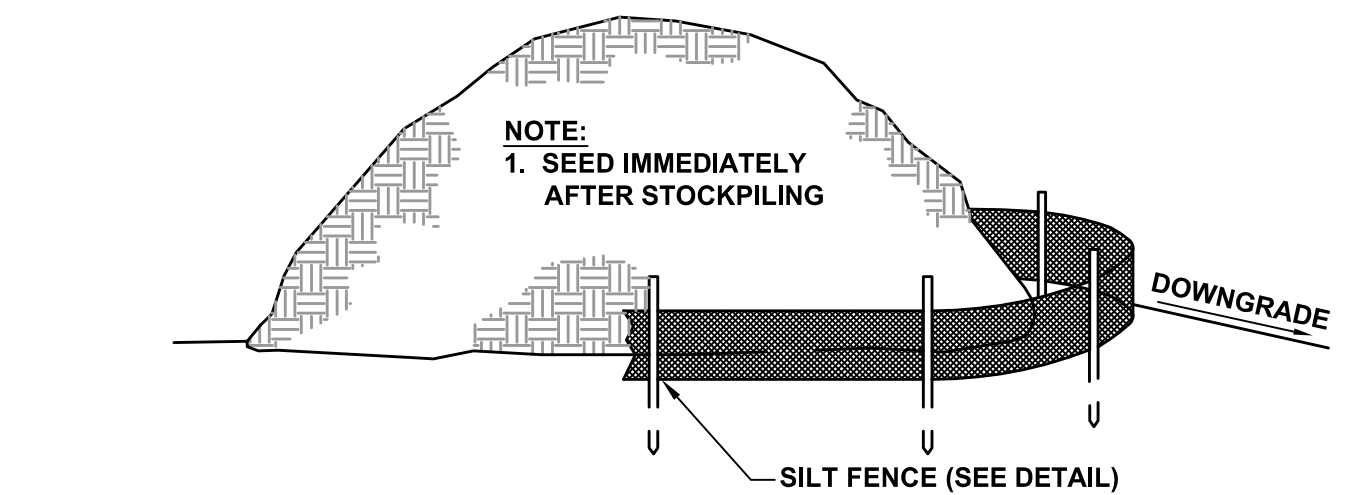

TYPICAL TOPSOIL STOCKPILE
N.T.S.

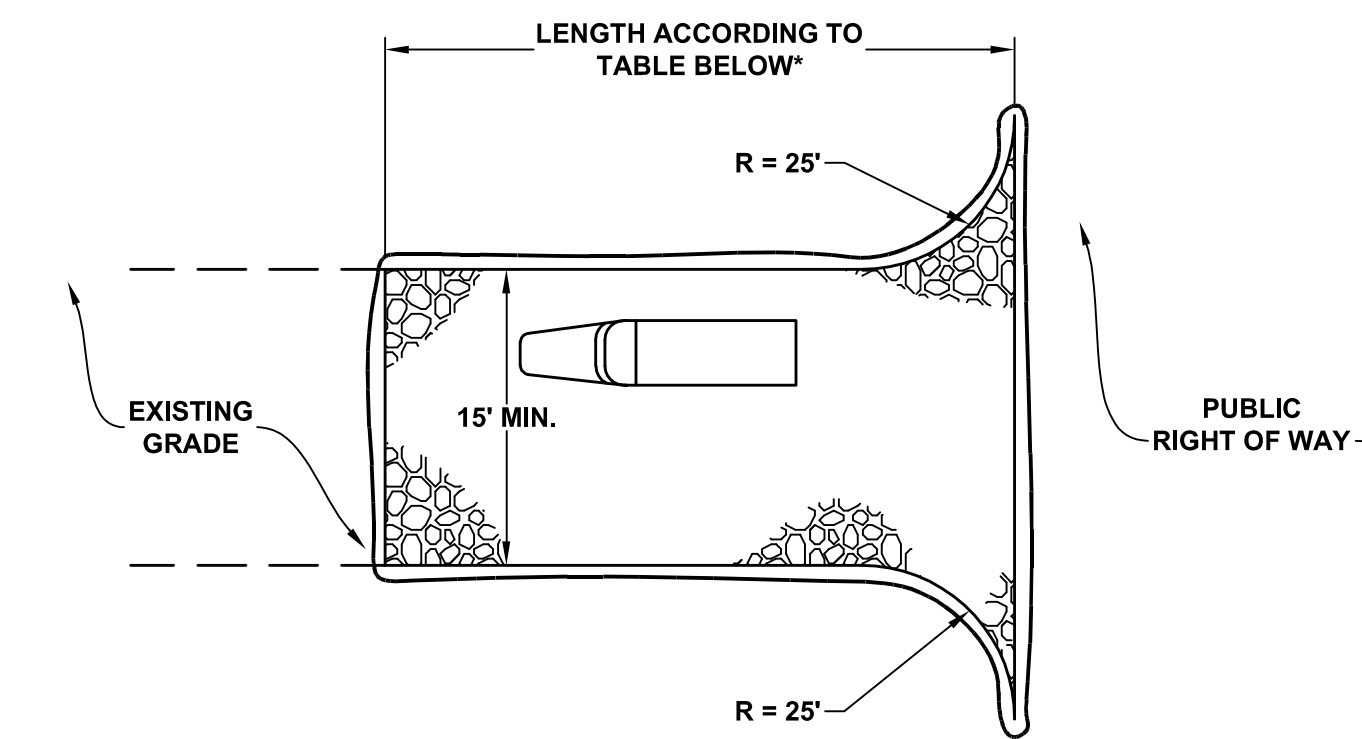
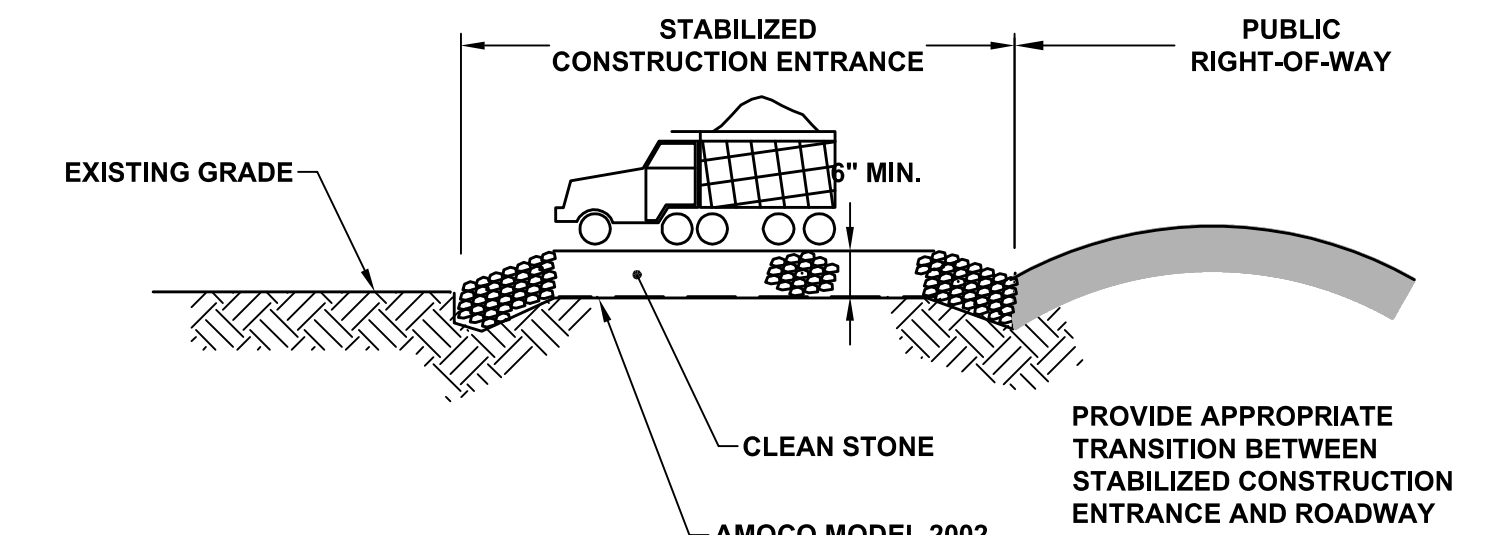

| PERCENT SLOPE OF ROADWAY | LENGTH STONE REQUIRED | |
|--------------------------|--|--------------------|
| | COARSE GRAINED SOILS | FINE GRAINED SOILS |
| 0 TO 2% | 50 FT. | 100 FT. |
| 2 TO 5% | 100 FT. | 200 FT. |
| > 5% | ENTIRE SURFACE STABILIZED WITH FABC BASE COURSE* | |

*AS PRESCRIBED BY LOCAL ORDINANCE OR OTHER GOVERNING AUTHORITY.

STABILIZED CONSTRUCTION ENTRANCE
N.T.S.

NOTICE

THIS DRAWING AND ALL INFORMATION CONTAINED HEREIN IS AUTHORIZED FOR USE ONLY BY THE PARTY FOR WHOM THE WORK WAS CONTRACTED OR TO WHOM IT IS CERTIFIED.

THIS DRAWING MAY NOT BE COPIED, REPRODUCED, DISCLOSED, DISTRIBUTED, OR RELIED UPON FOR ANY OTHER PURPOSE WITHOUT THE WRITTEN CONSENT OF SUBURBAN CONSULTING ENGINEERS, INC.

PER N.J.A.C. ELECTRONIC SUBMISSIONS NOT CONTAINING A VALID DIGITAL SEAL OR PAPER COPIES NOT CONTAINING A PAPER SEAL ARE NOT ORIGINALS AND MAY HAVE BEEN ALTERED.

© COPYRIGHT 2020 SUBURBAN CONSULTING ENGINEERS, INC.™

ALL RIGHTS RESERVED

| ISSUED FOR CONSTRUCTION | NO. | DATE: | BY: | CHK: |
|-------------------------|-----|------------|-----|------|
| | | 07/31/2020 | KRD | RCG |

REVISIONS

DAREN J. PHIL, PE
 NJ PROFESSIONAL ENGINEER
 LICENSE NO. 349603619100

DATE: 07/31/2020

SC E SUBURBAN CONSULTING ENGINEERS, INC.

COA NO.: 24C128037500
 210110004240

Civil Engineers - Municipal Engineers -
 Planners - Landscape Architects -
 Environmentalists - Land Surveyors -

96 US Highway 206, Suite 101 2430 Highway 34, Bldg. A Suite 1B
 Flemington, NJ 07836-9733 973.398.1776 Wall, NJ 08736-7322 282.1776

EXCELLENCE ♦ ECONOMY ♦ ENVIRONMENT

THE COLLEGE OF NEW JERSEY FIELD HOCKEY/LACROSSE FIELD E-LAYER REPLACEMENT

TOWNSHIP OF EWING, COUNTY OF MERCER, STATE OF NEW JERSEY

CONSTRUCTION DETAILS AND SOIL EROSION NOTES AND DETAILS

PROJECT NUMBER: SCE-9899.021
 SCALE: N.T.S.
 SHEET 5 OF 5
 REVISION _