

**To: All Vendors Bidding on The College of New Jersey
New Residence Hall Mold Remediation and Restoration Project**

From: The College of New Jersey

Date: May 6, 2020

ADDENDUM NO. 1

ISSUE DATE: May 6, 2020

REFERENCE: The College of New Jersey
New Residence Hall Mold Remediation and Restoration Project
Bid No. AB200029

Date of Original Bidding Documents: April 26, 2020

INTENT: This Addendum forms a part of the Contract Documents and modifies the original Bidding Documents and Prior Addenda if any, as identified above. Acknowledge receipt of this Addendum in the space provided on the Bid Form. Failure to do so may subject Bidder to disqualification.

CONTRACTOR QUESTIONS:

Q: I did not see any mention of a site visit. Will a site visit be allowed?

A: There will be no site visit. A detailed scope of work will be provided by the consultant after investigation (before remediation begins)

Q: Confirm, all contents cleaning will be limited to non-porous surfaces other than mattress. Verify no upholstery cleaning is expected (i.e. hot water steam extraction, etc.). Furniture cleaning will be Hepa and damp wipe only?

A: Some desk chairs are upholstered. Furniture will include HEPA vac and damp-wipe only. Carpeted rooms will be vacuumed only.

Q: Can additional detail/conditions be provided to price Part III. Is all furniture on site? Is it in the center of the room covered in plastic. Is it possible to have inventory of typical townhouse. Detail of expectations appears limited for Part III. Also, this is a vacuum and wipe of hard surfaces only? Soft to be vacuum only, not wet cleaning of any upholstery? This cleaning will be limited to inspection by TCNJ staff only, not IAQ consultant? For Part III, cleaning is limited to furniture only, TCNJ or others will ready the townhouse for occupancy (other than furniture)?

A: All furniture is in the room. Contractor will shift furniture to access walls/ceiling. Contractor will protect furniture with plastic. Bedrooms are typically double occupancy.

Inventory per student:

- 1 desk & chair
- 1 bed frame/mattress
- 1 wardrobe closet
- 1 nightstand
- 1 dresser

Q: Is the contractor allowed to use the restrooms in the townhouses? Is the contractor to provide a temporary toilet?

A: The Contactor may use toilets in rooms that are pre-selected by TCNJ – two (2) per floor. Toilet rooms must be cleaned by the Contractor prior to handover.

Q: There is no need for carpet cleaning (again if so, not hot water steam extraction)?

A: Bedrooms are carpeted. Cleaning by vacuum only.

Q: Will the contractor be able to contact the IAQ consultant at any time, or will they require a minimum amount of units available prior to making an inspection?

A: The IAQ Consultant will have a representative on-site during all Contractor activities. A Project Directory will be created for the successful bidder.

Q: Similar to the temporary toilet, is the contractor allowed to use the electric in the subject townhouses?

A: YES.

Q: The areas provided for quantities for the drywall removal. Is there any "pattern" for this work or typical scenario, or is this work spread out throughout the unit. Primarily bedrooms?

A: 3rd Floor, ceiling above valance may require drywall replacement before installing Azek.

Q: No HVAC work is required?

A: Valance Cleaning included. Supply/Exhaust duct/grill cleaning will be completed by another contract.

Q: Does “surface” clean, i.e. a dresser/night stand/wardrobe mean exterior only or pull drawers out and clean all sides of drawers and reset? That is for Part II, is level of cleaning for Part III less?

A: Part II. Include interiors. Part III, Furniture cleaned but not remediated.

Q: Part III pricing, All rooms shown in floor plans, Clean all rooms in all 24 townhouses, regardless of any remediation in the room?

A: At the end of the project, all rooms handed over clean and ready for use. Regular cleaning contract is for rooms that have no remediation involved. The bid form has been revised to reflect this.

Additional Information:

In addition to the questions received, a new bid sheet has been released in this addendum. Please use this for bidding purposes.



The cleaning scope has been modified as follows:

The intent is for all rooms to be handed over clean and ready for occupancy at the end of the project. Rooms that are remediated will be clean for occupancy (furniture must be returned to standard location). Rooms that are not remediated will need cleaning. The bid sheet has been modified to reflect this by specifying a quantity of rooms. This will be adjusted once the extent of remediation is known.

Azek Installation:

Revised 02 85 00, 3.2.H. Gypsum ceiling will remain in place. Azek will be purchased, cut to size and drip edge prepared by TCNJ. Contractor is responsible for final cut for room width and to install to gypsum ceiling. Caulk. Paint.

Revised 02 85 00, 3.2.P. Unit Price 2: Install 3/8" cellular polyvinyl chloride (PVC) board (supplied and prepared by TCNJ), above valance(s) on both (long) edges. Area is typically 16'x12' above valance. Caulk joints.

Typical Valance Section

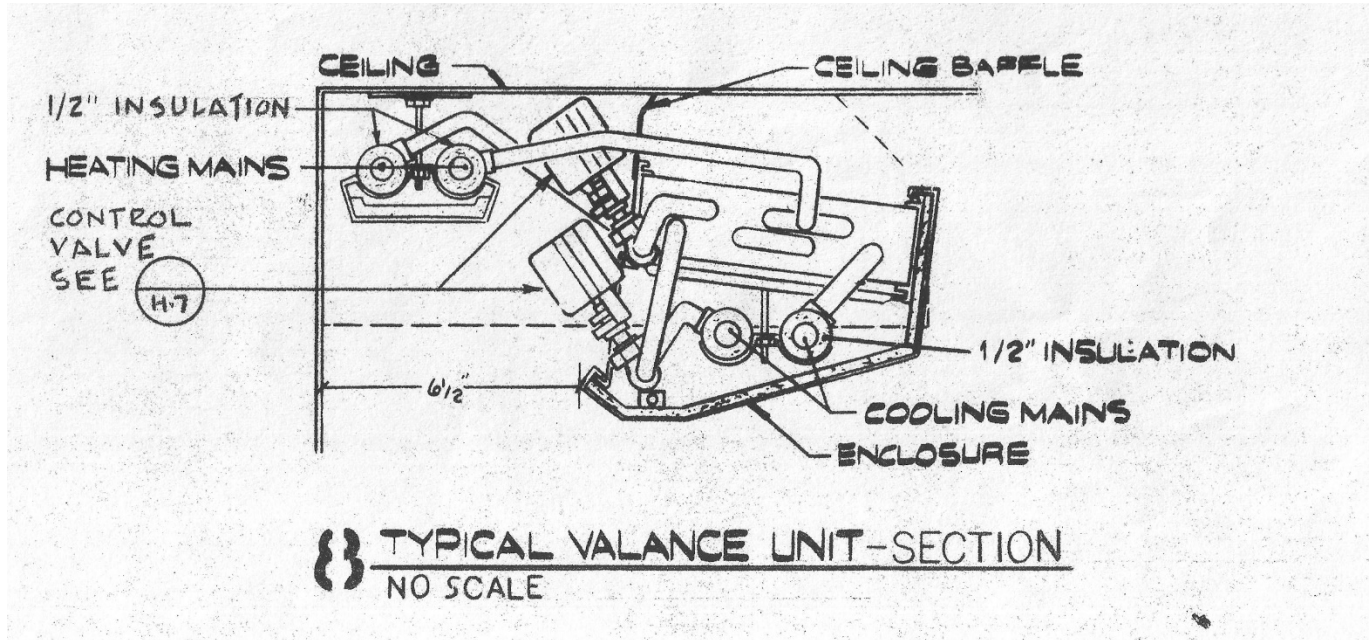

Attachments: Revised Bid Sheet

END OF ADDENDUM NO. 1

Mold Remediation & Restoration

Eickhoff Hall

Company Name: _____

AB200028, Addendum 1

Bid Sheet:

Part 1, Insurance and Bonding, Mobilization

Price \$ _____

Part 2, Remediation/Repair Scope of Work

	Area (sf)	#	Unit Cost	Item Total
1 Drywall removal, wall cleaned out, new insulation, drywall replaced/taped and spackled	a 4	25	x \$ _____ = \$ _____	
Use 5/8" Mold Resistant Gypsum board, provide blocking where required	b 16	25	x \$ _____ = \$ _____	
(Listed in 3 sizes)	c 32	50	x \$ _____ = \$ _____	
2 Not used				
3 not used				
4 Painting tinted primer plus one coat. Typical 8 x 12 wall (corner to corner)	96	100	x \$ _____ = \$ _____	
5 Removal and cleaning and resetting of valance unit		116	x \$ _____ = \$ _____	
6 Surface clean and disinfect Desk and Chair.		100	x \$ _____ = \$ _____	
7 Surface clean and disinfect Bedframe and Mattress.		100	x \$ _____ = \$ _____	
8 Surface clean and disinfect Wardrobe Closet.		100	x \$ _____ = \$ _____	
9 Surface clean and disinfect Nightstand		100	x \$ _____ = \$ _____	
10 Surface clean and disinfect Dresser.		100	x \$ _____ = \$ _____	
11 Surface clean and disinfect rooms	a	90	x \$ _____ = \$ _____	
(a=typical bedroom, b=typical bathroom)	b	100	x \$ _____ = \$ _____	
				Total of Part 2 \$ _____
Part 3, Cleaning rooms by professional, commercial cleaners. Scope includes Floor cleaning, furniture, handle and switch wipedown, interior window cleaning		26	x \$ _____ = \$ _____	
				Grand Total (Parts 1, 2, 3) \$ _____

Above prices include all prevailing wages, overhead, profit, insurances, and fees as well as all materials for a complete turn key project. Also included in prices above:

- * Cost to move the furniture to the center of the room and cover with plastic prior to the work starting.
- * All costs for second shift work if necessary based on the volume indicated above and the time frame in the bidding documents.
- * Other items listed in the bid docs.

Investigation by the consultant prior to start of project will provide detailed scope of work (actual locations).

The final contract will be adjusted up or down based on the final quantities via a deduct or add change order upon job completion.